



## Charge amplifiers

Transparent manufacturing processes ensure quality and cut costs



### Absolute Attention for Tomorrow's World

Kistler develops measurement solutions consisting of sensors, electronics, systems and services. In the physical border area between emissions reduction, quality control, mobility and vehicle safety, we deliver excellence for a future- oriented world and create ideal conditions for Industry 4.0. We thereby facilitate innovation and growth for – and with – our customers.



Kistler stands for progress in motor monitoring, vehicle safety and vehicle dynamics and provides valuable data for the development of the efficient vehicles of tomorrow.



Kistler measurement technology ensures top performance in sport diagnostics, traffic data acquisition, cutting force analysis and other applications where absolute measurement accuracy is required.



Kistler systems support all steps of networked, digitalized production and ensure maximum process efficiency and profitability in the smart factories of the next generation.

# Contents

<b>Focus on quality and cost-effectiveness</b>	4
<b>Product overview: charge amplifiers</b>	6
Piezoelectric amplifiers	8
Strain gage amplifiers	15
<b>Measuring chains</b>	16
<b>Cables</b>	18
<b>Accessories</b>	26
<b>Charge amplifiers – technology</b>	28
<b>Kistler service: customized solutions from A to Z</b>	34
<b>Kistler – at our customers' service across the globe</b>	35



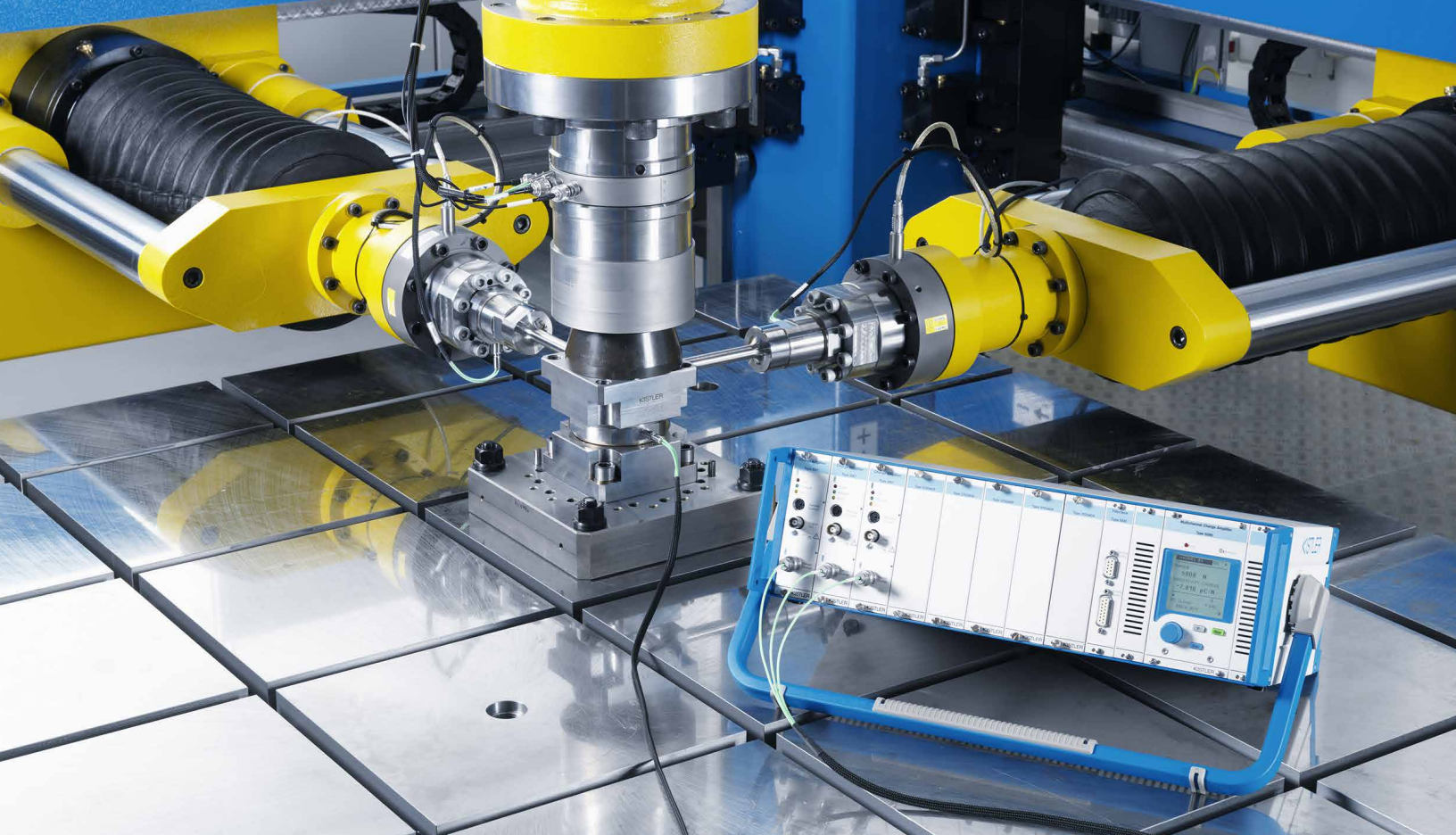

Assembly processes and product testing are just two of the many industrial activities where sensors from Kistler are used.

## Focus on quality and cost-effectiveness

**Quality and precision standards in industrial manufacturing are constantly increasing, and competition is becoming even fiercer – so it's essential to optimize and monitor the entire production chain. Kistler's measurement and system technology can help meet these requirements, laying the foundations for zero-defect industrial production.**

Ensuring the quality of the end product is always the top priority in the automotive industry and the medical technology or electrical engineering sectors (to mention only a few examples). This is why strict standards are specified in all these areas. Especially if many individual components are assembled to form one single product, each component must already have been tested by the suppliers: this is the only way to guarantee the quality of the end product.

In many such cases, the only solution is to integrate monitoring systems into the production process.

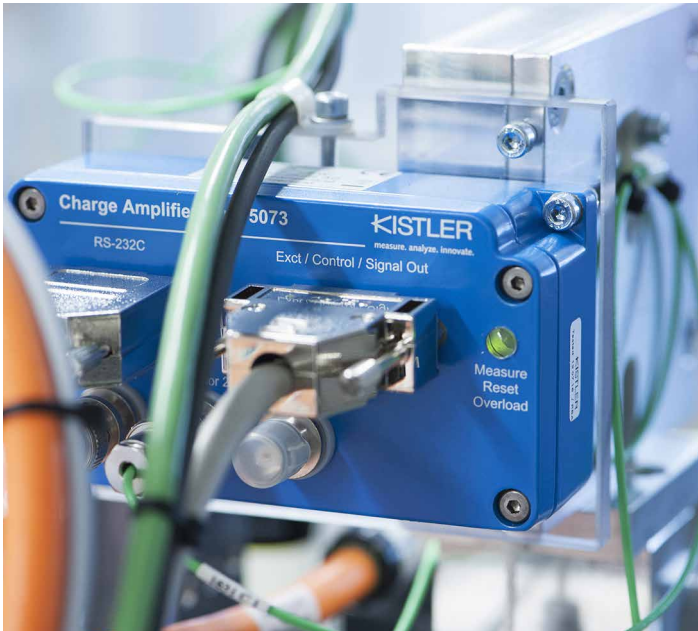

### **Optimized process efficiency thanks to technology from Kistler**

The objective: to implement zero-defect industrial production at the lowest possible cost. Kistler's response: integrated process monitoring, which means direct verification during each process step. This concept is underpinned by sensor technology based on the piezoelectric principle – an approach that is outstandingly suitable for monitoring and optimizing production processes.







### **Lower quality assurance costs for plant operators**



Process-integrated monitoring cuts the costs of quality assurance. This cost-effective solution protects plant operators against the possibility of faulty parts reaching the customer; it also ensures that there is no disruption to any downstream assembly operations.

### **Benefits**

- Forces and other process variables are measured during the production process
- Process monitoring ensures zero-defect production
- Quality costs are cut because deviations are detected at an early stage
- Process efficiency is optimized because the measuring equipment used is extremely flexible

# Product overview: charge amplifiers

Piezoelectric amplifiers		Frequency range Hz Measurement range pC					Signal output				Page	
Type		0	100	1000	10000	100000	1000000	Voltage	Current	Digital	channels	
5074A...	 Industrial charge amplifier, digital	[Light blue bar from 0 to 10000 Hz]								<input checked="" type="checkbox"/>	1 ... 4	8
5073A...	 Industrial charge amplifier, analog	[Light blue bar from 0 to 10000 Hz]						<input checked="" type="checkbox"/>	<input checked="" type="checkbox"/>		1 ... 4	9
5030A...	 Miniature charge amplifier	[Light blue bar from 0 to 1000 Hz]						<input checked="" type="checkbox"/>			1	10
5039A...	 Miniature charge amplifier	[Light blue bar from 0 to 10000 Hz]						<input checked="" type="checkbox"/>	<input checked="" type="checkbox"/>		1	10
5041E...	 Charge amplifier for front panel mounting	[Light blue bar from 0 to 1000 Hz]						<input checked="" type="checkbox"/>			1	11
5015	 1-channel charge meter	[Light blue bar from 0 to 10000 Hz]						<input checked="" type="checkbox"/>			1	12
5995A...	 Charge meter for piezoelectric sensors	[Light blue bar from 0 to 1000 Hz]						<input checked="" type="checkbox"/>			1	13

Strain gage amplifiers		Amplification mV/V											
Type		0	1	2	3	4	5						
4701B...	 Measuring amplifier for strain gage sensors		[Light blue bar from 1 to 3]					<input checked="" type="checkbox"/>				1	15
4703B	 Charge meter for strain gage sensors		[Light blue bar from 1 to 5]							<input checked="" type="checkbox"/>		1	15

■ Frequency range Hz    
 ■ Measurement range in pC    
 ■ Amplification mV/V    
 ■ Standard    
 □ Option





## The new standard for measurement in the Industry 4.0 era

Kistler's newly developed Type 5074A data acquisition unit breaks new ground in industrial charge amplifier technology. This unit is currently the only amplifier on the market for piezoelectric sensors with communication consistently based on Industrial Ethernet (IE).

For the first time, plant and machinery manufacturers can now integrate any desired piezoelectric sensors directly into a real time-capable Ethernet system, so they can easily make settings on the measuring amplifier via the control.

The Type 5074A charge amplifier is an ideal choice for monitoring and optimizing industrial press-fit, assembly and joining processes, among many others. It can be regarded as a digital version of the tried-and-tested Type 5073A analog charge amplifier. Complete digitization means that the new unit enables direct communication up to amplifier level. The 5074A features an exceptionally wide range of measuring functions, making it the perfect solution for all applications that call for dynamic and quasi-static measurements via Industrial Ethernet.



**Increased process efficiency with Kistler – now online!**

View our animation to experience convincing, first-class Kistler solutions – the sure way to optimize process efficiency:

[www.kistler.com/ca5074](http://www.kistler.com/ca5074)



# Piezoelectric amplifiers

## Industrial charge amplifier, digital



Type 5074A4...



Technical data		Type	5074A1...	5074A2...	5074A3...	5074A4...
Number of channels			1	2	3	4
Charge input			•	•	•	•
Measurement range	pC		±20 ... 1 000 000			
Frequency range (-3dB)	Hz		≈20 000 (<±900 pC) ≈10 000 (<±31 000 pC) ≈2 000 (<±1 000 000 pC)			
Time constant			long /short			
Connector type			KIAG 10-32UNF neg.			
TNC neg.			-			
BNC neg.			-			
Measurement range adjustment			continuously variable			
Analog output			-			
Operation	Network commands		PLC configuration			
Interfaces						
EtherCAT	μs <sub>min</sub>		100			
EtherNet/IP	μs <sub>min</sub>		1000			
PROFINET	μs <sub>min</sub>		250			
Connector type	Network Power		M12 4-pole D-coded M8 4-pole A-coded			
Energy supply						
Operating voltage	VDC		18 ... 30			
Power consumption	W		<4			
Deg. of protection to IEC/EN 60529			IP65 (screwed sensor connection) IP67 (welded sensor connection)			
Operating temperature range	°C		-20 ... 65			
External dimensions	L × H × W mm		150 × 64 × 44			
Other features			Activation of individual channels Peak value acquisition Internal scaling of measurement values Adaptable process data map Low-pass filter Oversampling up to 50kSps Integral value calculation			
<b>Data sheet: see <a href="http://www.kistler.com">www.kistler.com</a></b>			<b>5074A (003-332)</b>			



## Industrial charge amplifier, analog



Type 5073A4...

Technical data	Type	5073A1...	5073A2...	5073A3...	5073A4...	5073A5...
Number of channels		1	2	3	4	1 (4 inputs summed)
Number of measurement ranges		2 (switchable)				
Measurement range adjustment		continuously variable				
Measurement range 1 FS	pC	±100 ... 1 000 000				
Measurement range 2 FS	pC	±100 ... 1 000 000				
Frequency (-3 dB)	kHz	≈0 ... 20 (<±10 100 pC)				
		≈0 ... 2 (<±1 000 000 pC)				
Output signal	V	±10				
	mA	4 ... 20 (only 5073A1... and 5073A2...)				
Power supply	VDC	18 ... 30				
Signal input	Type/ connector	piezoelectric/acc. to choice BNC neg. TNC neg.				
Operating temperature range	°C	0 ... 60				
Deg. of protection to IEC/EN 60529		acc. to choice IP60 (BNC) IP65 (TNC)				
Interface		RS-232C				
Other features		Peak memory Adjustable output offset Low-pass filter Option: time constant Switch inputs electrically isolated PC software: ManuWare				
<b>Data sheet: see <a href="http://www.kistler.com">www.kistler.com</a></b>		<b>5073A (000-524)</b>				

## Miniature charge amplifier



Type 5030A...

Technical data	Type	5030A...
Number of channels		1
Number of measurement ranges		2 (switchable 10:1)
Measurement range adjustment		Fixed
Measurement ranges FS	pC	acc. to choice $\pm 1000 / \pm 100$ $\pm 10000 / \pm 1000$ $\pm 100000 / \pm 10000$
Frequency range (-3 dB)	kHz	$\approx 0 \dots 10$
Output signal	V	$\pm 10$
Power supply	VDC	18 ... 30
Signal input	Type/connector	Piezoelectric/KIAG 10-32 neg.
Operating temperature range	°C	0 ... 70
Deg. of protection to IEC/EN 60529		IP65
<b>Data sheet: see <a href="http://www.kistler.com">www.kistler.com</a></b>		<b>5030A (000-523)</b>



Type 5039A...

Technical data	Type	5039A...
Number of channels		1
Number of measurement ranges		2 (10:1, 4:1 or 2:1)
Measurement range adjustment		Fixed
Measurement ranges FS	pC	$\pm 5000 \dots 50000$
Frequency range (-3 dB)	kHz	$\approx 0 \dots 17$
Output signal	V mA (option)	$\pm 10$ 4 ... 20
Power supply	VDC	18 ... 36
Signal input	Type/connector	Piezoelectric/acc. to choice BNC neg. TNC neg.
Operating temperature range	°C	0 ... 60
Deg. of protection to IEC/EN 60529		acc. to choice IP40 (BNC) IP65 (TNC)
Other features		According to choice: peak value output or current output Switch inputs electrically isolated
<b>Data sheet: see <a href="http://www.kistler.com">www.kistler.com</a></b>		<b>5039A (000-303)</b>

## Charge amplifier for front panel mounting



Type 5041E...

Technical data	Type	5041E...
Number of channels		1
Measurement range adjustment		Digitally adjustable
Measurement range FS	pC	±100 ... 99 900
Frequency range (-3 dB)	kHz	≈0 ... 50
Output signal	V	±10
Power supply	VDC	acc. to choice ±15 24
Signal input	Type/connector	Piezoelectric/BNC neg.
Operating temperature range	°C	0 ... 50
Deg. of protection to IEC/EN 60529		IP40
<b>Data sheet: see <a href="http://www.kistler.com">www.kistler.com</a></b>		<b>5041E (000-305)</b>

## 1-channel charge meter



Type 5015A...

Technical data	Type	5015A...
Number of channels		1
Measurement range adjustment		continuously variable
Measurement range FS	pC	$\pm 2 \dots 2\,200\,000$
Frequency range (-3 dB)	kHz	$\approx 0 \dots 200$
Output signal	V	$\pm 2 / \pm 2,5 / \pm 5 / \pm 10$
Power supply	VAC	115, 230
Amplifier module		acc. to choice <ul style="list-style-type: none"> <li>• Charge amplifier</li> <li>• Dual mode (voltage/charge) with Piezotron®</li> </ul>
Connector	Type	BNC neg.
Time constant		long/medium/short
Operating temperature range	°C	0 ... 50
Deg. of protection to IEC/EN 60529		IP40
Interface		acc. to choice <ul style="list-style-type: none"> <li>• RS-232C</li> <li>• RS-232C and IEEE-488</li> </ul>
Housing		acc. to choice <ul style="list-style-type: none"> <li>• 19" cassette for rack mounting</li> <li>• Desktop unit with support bracket</li> <li>• 19" cassette with panel mounting set</li> </ul>
Other features		<ul style="list-style-type: none"> <li>• Laboratory measuring instrument with DSP</li> <li>• Peak value display</li> <li>• Display of mechanical measurand</li> </ul>
<b>Data sheet: see <a href="http://www.kistler.com">www.kistler.com</a></b>		<b>5015A (000-297)</b>



## 1-channel handheld charge amplifier



Type 5995A...

Technical data	Type	5995A...
Number of channels		1
Measurement range adjustment		Stages 1, 2, 5
Measurement range FS	pC	±200 ... 200 000
Frequency range (-3 dB)	kHz	≈0 ... 10
Display:	Digits	3½ (2 000)
Output signal	V	±2
Power supply (battery)	VDC	9
Signal input		Piezoelectric/BNC neg.
Deg. of protection to IEC/EN 60529		IP50
Other features		Adjustable to physical unit Peak value acquisition Automatic switchoff
<b>Data sheet: see <a href="http://www.kistler.com">www.kistler.com</a></b>		<b>5995A (000-312)</b>

## Charge generator for piezoelectric amplifiers



Type 5363A...

Technical data	Type	5363A...
Output charge range	pC pC pC	0 ... $\pm 10^3$ (100pF) 0 ... $\pm 10^4$ (1nF) 0 ... $\pm 10^5$ (10nF)
Output voltage range	V	0 ... $\pm 10$
Range adjustment	%	0 ... $\pm 100$
Error	% FSO	$< \pm 3$
Signal output	V Q	BNC neg. BNC neg.
Operating temperature range	$^{\circ}\text{C}$	0 ... 50
Deg. of protection to IEC/EN 60529		IP50
Dimensions	mm	164 × 84,6 × 56,1
Other features		Battery operation 2 × IEC LR6
<b>Data sheet: see <a href="http://www.kistler.com">www.kistler.com</a></b>		<b>5363A (003-336)</b>

## Insulation tester for piezoelectric measuring chains



Type 5493...

Technical data	Type	5493...
Number of channels		1
Measurement range adjustment		–
Measurement range FS	$\Omega$	$10^{11}$ ... $4 \cdot 10^{13}$
Measurement voltage	V	5
Max. parallel capacity (cable length)	nF m	10 100
Power supply (battery)	VDC	9
Signal input		BNC neg.
Deg. of protection to IEC/EN 60529		IP50
Other features		Automatic switchoff
<b>Data sheet: see <a href="http://www.kistler.com">www.kistler.com</a></b>		<b>5493 (000-354)</b>

# Strain gage amplifiers

## Measuring amplifier for strain gage sensors



Type 4701A...  
Version A



Type 4701A...  
Versions B and C

Technical data	Type	4701A...
Number of channels		1
Signal input	Strain gage	mV/V
	Resistive	V
Cutoff frequency (-3 dB)	kHz	1
Measurement range adjustment	%	≈±10
Zero point setting	%	≈±10
Output signal	V	±0 ... 5 or ±0 ... 10
Power supply	VDC	24 non-stabilized (±10 %)
Signal input	Type/connector	Strain gage with option of cable gland with soldering terminals (version A) 6-pole connector (version B)
Operating temperature range	°C	0 ... 50
Deg. of protection to IEC/EN 60529		Version A with cable bushings: IP54 Versions B and C with plug connectors: IP40
<b>Data sheet: see <a href="http://www.kistler.com">www.kistler.com</a></b>		<b>4701A (000-621)</b>

## Charge meter for strain gage sensors



Type 4703B...

Technical data	Type	4703B...
Number of channels		1
Impedance strain gauge full bridge	Ω	350
Sensitivity (S)	mV/V	0,3 ... 5
Sensor supply voltage	VDC/V	5
Measurement rate	1/s	6,25 ... 1600
Power supply (battery)	VDC	3 ... 4,8
Signal input		6-pole binder-round connector
Deg. of protection to IEC/EN 60529		IP54
Dimensions	mm	82 × 162 × 54
Other features		USB connection PC software: SensorTool
<b>Data sheet: see <a href="http://www.kistler.com">www.kistler.com</a></b>		<b>4703B (000-762)</b>

# Measuring chains

In order to integrate sensor technology into a given application, it is advisable to clarify these points in advance. This will provide the basis for selecting the relevant components to generate the measuring chain:

- Type of signal: voltage, frequency, digital (fieldbus/Ethernet) or charge for piezoelectric sensors
- Number of pins of the selected output
- Pin allocation for sensor and evaluation unit (see data sheet)

When installing the cables, make sure that the maximum permitted cable length is not exceeded. It is advisable to use original Kistler cables only.

Piezoelectric sensors require a charge amplifier. After the sensor signals have been converted, they can be evaluated by an amplifier in the customer's system.

For the analysis of dedicated XY processes (such as torque-rotation angle monitoring), the maXYmos family is highly suitable thanks to its user-friendly operation and wide variety of interfaces (Y-channel: piezo, strain gage, +/- 10 V; X-channel: potentiometer, +/- 10 V, incremental).

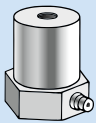
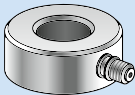
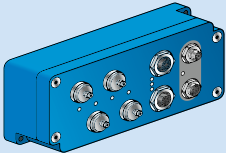
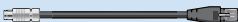
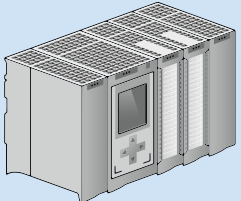
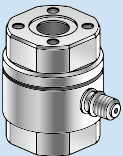
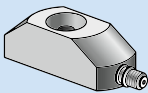
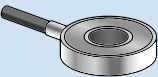
Measure	Connect	Amplify	Connect	Monitor & control
8202A... 8203A...				
90x1A 90x1B 910xA	1635C... 1641B... 1957A... 1967A... 1969A... 1983AC... 	5074A... 	Network cable Power cable 	PLC 
93x3A				
9232A...				
913xB...				



Measure

Connect

Amplify

Monitor & control

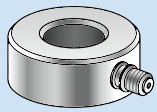

Type 9103A

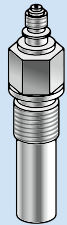

Type 9217A

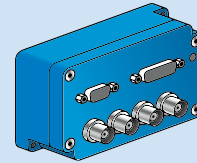
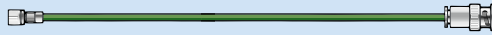

Type 5073A

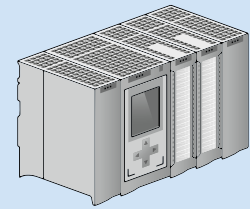

PLC

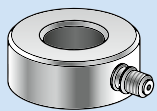

Type 9103A

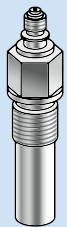

Type 9217A

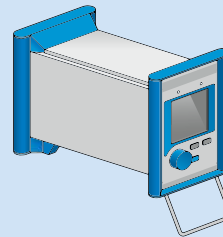
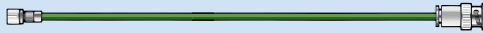

Type 5016A

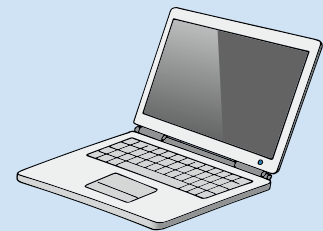

Notebook

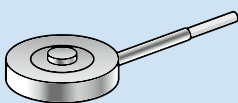

Type 4577A

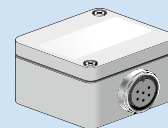

Type 4701A

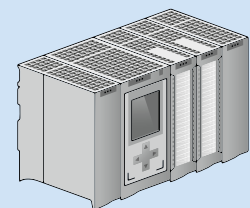

PLC

# Cables

As a mandatory requirement, piezoelectric sensors and charge amplifiers must be connected with high-insulation cable (insulation resistance  $>10^{13} \Omega$ ).

In contrast to standard coaxial cables, the innermost wire of high-insulation cables is insulated with PTFE. This reduces the drift effect to the absolute minimum. In addition, a special graphite sheathing minimizes the triboelectric effect. There are various versions (with corresponding properties) for the outermost insulation

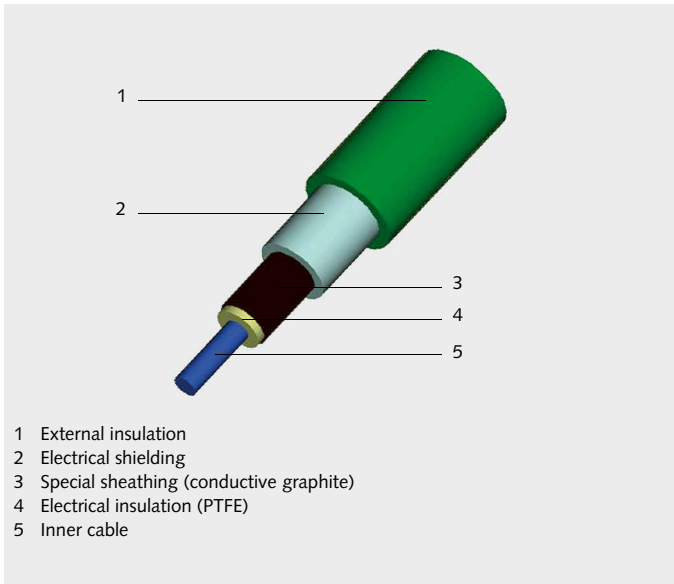

Structure of a Kistler high-insulation cable

casing (see: Cable versions).

As well as using high-insulation cables when working with piezoelectric measuring chains, it is also important to ensure that all connectors and sockets are always clean. It is recommended to leave the protective caps on the sockets of sensors and charge amplifiers until they are connected. The protective caps should be fitted again whenever components are disconnected or placed in storage. If connectors become dirty, they can be cleaned with Kistler Cleaning Spray, Type 1003.

The 'triboelectric effect' is the name of the phenomenon whereby the movement of a cable causes minimal charges to occur on the surface of the conductor. Thanks to the special graphite sheathing, however, the influence of the triboelectric effect is very small in the case of Kistler high-insulation cables ( $<1 \text{ pC}$  with high vibrations). Nevertheless, when installing cables, it is always advisable to ensure that they are exposed to the minimum of vibrations and movements.

## Cable versions

### PFA cable (ø2 mm)

The outer insulation of high-insulation PFA cable consists of a material similar to PTFE, so it exhibits excellent thermal stability and outstanding resistance to chemicals. The PFA cable is entirely adequate for most applications with temperatures up to 200°C.



PFA cable

### PFA cable with stainless steel braiding (ø2,6 mm)

PFA cable with stainless steel braiding is especially advisable for applications where the cable is subject to mechanical stress (e.g. vibration-induced friction, sharp edges, etc).

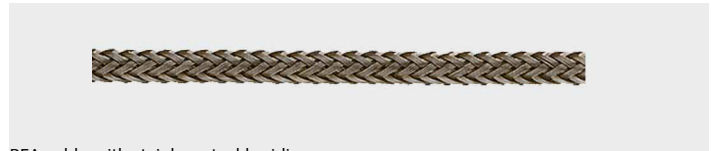

PFA cable with stainless steel braiding

### FKM cable(ø2 mm)

FKM cable also features high thermal and chemical resistance, and can be used at temperatures of up to 200°C. In contrast to PFA cable, however, the cable connectors are vulcanized. Tight solutions to IP68 can be achieved by welding the cable connector and the sensor connector.



FKM cable

## Cable lengths

All Kistler cables are available in standard and custom lengths. Standard lengths are kept in stock, so they offer the advantage of shorter delivery times.

## Cable connections

### Cable connectors: sensor side

Different cable connectors are required depending on the sensor type: KIAG 10-32 UNF pos or M4x0,35 pos. Each of these two cable connectors is available with a rotatable swivel nut or a fixed threaded connection that can be welded on.

Thanks to the rotatable swivel nut, cables with a **KIAG 10-32 pos.** or **M4x0,35 pos.** connector can be screwed and unscrewed quickly with no need to rotate the entire cable at the same time. This is a particular advantage for applications that require frequent removal or reconnection of the cable.

The **KIAG 10-32 pos. int.** or **M4x0,35 pos. int.** cable connector has an integrated thread, so the cable rotates at the same time when the connector is screwed and unscrewed. This connector is particu-

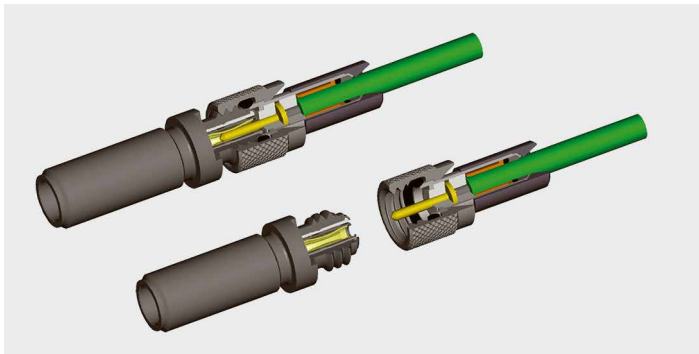

KIAG 10-32 pos. – connector with rotatable swivel nut

larly advantageous if the cable connector has to be welded to the sensor. In the case of PFA cables, welding the cable connector to the sensor offers good protection against detachment of the cable if the measuring chain is subject to strong vibrations. If high tightness (IP68) is required, FKM cable is preferable.

If you intend to weld the connector to the sensor, please state this when placing your order.

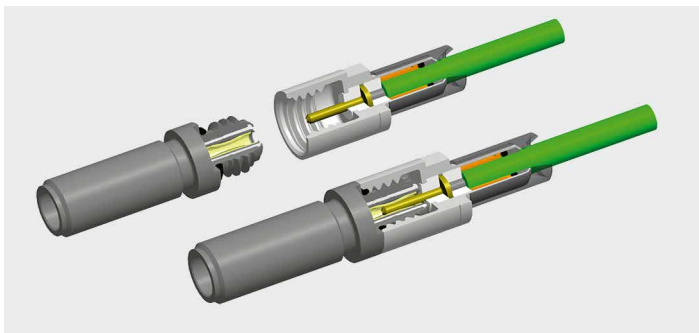

KIAG 10-32 pos. int. - connector with integrated thread

### Cable connectors: charge amplifier side

In most cases, a **BNC pos.** cable connector is required when connecting the cable directly to the charge amplifier. Most cables are available in this version. However, these cables are not suitable for certain applications where the cable has to be routed through small openings.

Cables with a KIAG 10-32 pos. (int.) cable connector on both sides, or with an M4x0,35 pos. (int.) connector on the sensor side and a **KIAG 10-32 pos. (int.)** connector on the charge amplifier side, are more suitable for this purpose. KIAG 10-32 connectors ( $\varnothing 6$  mm) and M4x0,35 connectors ( $\varnothing 5$  mm) have smaller diameters than BNC connectors ( $\varnothing 15$  mm), so they can be routed through smaller openings.

The KIAG 10-32 cable connector can then be connected to the BNC socket of the charge amplifier with a Type 1721 coupling.

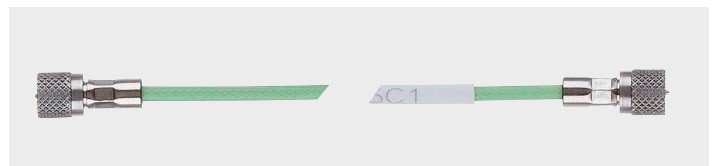

Cable with KIAG 10-32 pos. connector, both sides

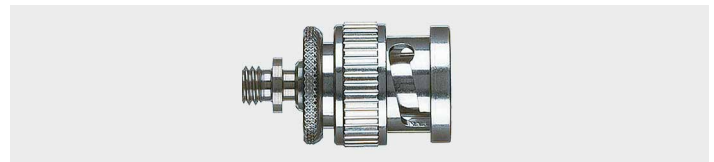

Type 1721 coupling (KIAG 10-32 neg. to BNC pos.)

# Overview of cables

Sensor family	Cables				
	Technical data	Type	Connector		Length (standard) [m]
			Left	Right	
9232A... 90x1 910x 93x1 93x3 9217		1631C...	KIAG 10-32 pos.	BNC pos.	0,5 / 1 / 2 / 3 / 5 / 10 / 20
		1641B...	KIAG 10-32 pos. 90°	BNC pos.	0,5 / 1 / 2 / 5
		1939A...	KIAG 10-32 pos. int.	BNC pos.	1 / 2 / 3
		1635C...	KIAG 10-32 pos.	KIAG 10-32 pos.	0,5 / 1 / 2 / 3 / 5 / 10
		1957A...	KIAG 10-32 pos.	KIAG 10-32 pos.	1
		1969A...	KIAG 10-32 pos. int.	KIAG 10-32 pos. int.	1
		1967A...	KIAG 10-32 pos. int.	KIAG 10-32 pos. int.	0,5 / 1 / 2 / 3
		1983AD...	KIAG 10-32 pos. int.	BNC pos.	0,5 / 1 / 1,5 / 2 / 2,5 / 3 / 5
		1983AC...	KIAG 10-32 pos. int.	KIAG 10-32 pos. int.	0,5 / 1 / 1,5 / 2 / 2,5 / 3 / 5
		1633C...	KIAG 10-32 pos.	TNC pos.	0,5 / 1 / 2 / 5
		1941A...	KIAG 10-32 pos. int.	TNC pos.	1 / 2 / 3
		1943A...	KIAG 10-32 pos. int.	Mini-Coax neg.	1 / 2 / 3
	9243B 9247A 601CAB		1651C...	M4x0,35 pos.	BNC pos.
		1923A...	M4x0,35 pos. int.	KIAG 10-32 pos. int.	0,5 / 1
		1983AB...	M4x0,35 pos. int.	KIAG 10-32 pos. int.	0,5 / 1 / 1,5 / 2 / 3 / 5
		1951A...	M4x0,35 pos. int.	KIAG 10-32 pos.	0,4
9240AA3 913x		1721	Cable is integrated in the sensor -> Connection to charge amplifier with coupling 1721 (KIAG 10-32 neg. – BNC pos.)		
		1637C...	KIAG 10-32 neg.	KIAG 10-32 pos.	5



	Length (custom) [m]		Cable sheathing material	Operating temperature range [°C]		Cable can be welded to sensor		Deg. of protection to IEC/EN 60529		Comments
	min.	max.		min.	max.	Yes	No	Left	Right	
	0,1	100	PFA	-55	200		•	IP65	IP40	Standard cable for most applications
	0,1	100	PFA	-55	200		•	IP40	IP40	
	0,1	100	PFA	-55	200	•		IP65 -> screwed connection IP67 -> welded connection	IP40	
	0,1	100	PFA	-55	200		•	IP65	IP65	
	0,1	10	PFA with stainless steel braiding	-55	200		•	IP65	IP65	
	0,1	10	PFA with stainless steel braiding	-55	200	•		IP65 -> screwed connection IP67 -> welded connection	IP65	
	0,1	10	PFA with stainless steel braiding, ground-isolated	-55	200	•		IP65 -> screwed connection IP67 -> welded connection	IP65	
	0,2	20	FKM	-20	200	•		IP65 -> screwed connection IP68 -> welded connection	IP40	
	0,2	20	FKM	-20	200	•		IP65 -> screwed connection IP68 -> welded connection	IP65	
	0,1	50	PFA	-55	200		•	IP65	IP65	Diameter 2 (PFA)
	0,1	20	PFA	-55	200	•		IP65	IP65	Diameter 2 (PFA)
	0,1	10	PFA	-55	200	•		IP65	IP40	Diameter 2 (PFA)
	0,1	100	PFA	-55	200		•	IP65	IP40	Standard cable for most applications
	0,1	100	PFA	-55	200	•		IP65 -> screwed connection IP67 -> welded connection	IP65	
	0,2	20	FKM	-20	200	•		IP65 -> screwed connection IP68 -> welded connection	IP65	
	0,1	5	Kapton with stainless steel braiding	-55	300	•		IP65	IP65	Diameter 2,6 (Kapton with high-grade steel braiding)
							•			Couplings for cables (see page 26)
	0,3	5	PFA	-55	200		•	IP65	IP65	Extension cable for 1635C...

## Cables for 2-component and 3-component sensors

**As a mandatory requirement, piezoelectric force sensors and charge amplifiers must be connected with a high-insulation cable (insulation resistance  $>10^{13} \Omega$ ).**

In contrast to standard coaxial cables, the innermost wire of high-insulation cables is insulated with PTFE. This reduces the drift effect to the absolute minimum. In addition, a special graphite sheathing minimizes the triboelectric effect. There are various versions (with corresponding properties) for the outermost insulation casing (see: Cable versions).

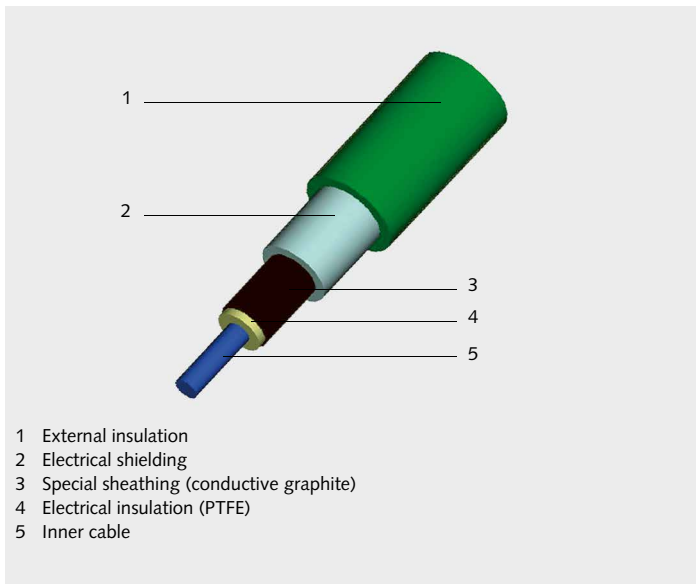

Structure of a Kistler high-insulation cable

The points set out in the next two sections are especially important when measuring very small forces in the Newton range.

As well as using high-insulation cables when working with piezo-electric measuring chains, it is also important to ensure that all connectors and sockets are always clean.

It is recommended to leave the protective caps on the sockets of force sensors and charge amplifiers until they are connected.

The protective caps should be fitted again whenever components are disconnected or placed in storage.

If connectors become dirty, they can be cleaned with Kistler Cleaning Spray, Type 1003.

The 'triboelectric effect' is the name of the phenomenon whereby the movement of a cable causes minimal charges to occur on the surface of the conductor. Thanks to the special graphite sheathing, however, the influence of the triboelectric effect is very small in the case of Kistler high-insulation cables ( $<1 \text{ pC}$  with high

vibrations). Nevertheless, when installing cables, it is always advisable to ensure that they are exposed to the minimum of vibrations and movements.

### Cable versions

#### PFA cable with plastic braiding (ø6 mm)

The structure of this 3-wire cable consists of three individual PFA cables. The cables are surrounded by plastic braiding which holds them together. The outer insulation of the individual high-insulation PFA cables consists of a material similar to PTFE, so it exhibits excellent thermal stability and outstanding resistance to chemicals. The PFA cable with plastic braiding is entirely adequate for most applications with temperatures up to  $120^\circ\text{C}$ .



PFA cable with plastic braiding

#### TPE cable (ø3,6 mm)

TPE cable is a high-insulation 3-wire cable with sheathing made of TPE, a thermoplastic elastomer.

This cable is suitable for applications with temperatures up to  $120^\circ\text{C}$  in harsh environments (e.g. dust and splash water).



FKM cable

#### FKM cable with stainless steel braiding (ø7,5 mm)

The FKM cable is a high-insulation 3-wire cable with FKM sheathing, protected by stainless steel braiding. This cable's rugged structure makes it especially suitable for applications with temperatures up to  $120^\circ\text{C}$  where the cable is subject to mechanical stress (e.g. vibration-induced friction, sharp edges, etc).

Tight solutions to IP68 can be achieved by welding the cable connector and the sensor connector.

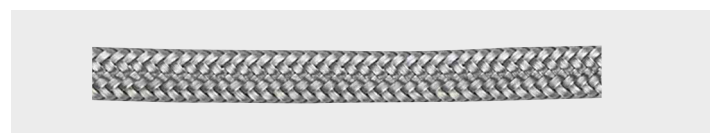

FKM cable with stainless steel braiding

## Cable lengths

All Kistler cables are available in standard and custom lengths. Standard lengths are kept in stock, so they offer the advantage of shorter delivery times.

## Cable connections

### Cable connectors: sensor side

The cables are connected to the sensor with a **V3 pos.** connector. In this highly integrated design, all three conductors are routed over the same connector; as compared to conventional single-connector solutions where each of the three conductors is routed over a single connector, this solution offers the following advantages:

- Simple, fast installation; a critical factor in applications where the cable is frequently removed and reconnected
- It is easier to ensure that the connector is tight because only one connector weld is needed

There are **two different versions of the V3 pos.** connector. In applications where it must be possible to detach the cable from the sensor at all times, the version with the **screw-type connector** should be chosen. If the application requires high tightness (IP68) for the connector, the version with the **weldable connector** should be chosen. In this case, please state on your order that the connector should be welded to the sensor.

The overview of cables on page 24 shows which cables are equipped with which connector versions.

### Cable connectors: charge amplifier side

Two connector versions are available to connect the cable to the charge amplifier; in this case, the choice of connector depends on the cable version (see the Overview of cables on page 24). In the case of the **2 x BNC pos.** or **3 x BNC pos.** versions, the sensor signals from the 2-component or 3-component sensors (respectively) are connected to the charge amplifier with two or three individual BNC pos. connectors. This version is entirely adequate for most applications in a laboratory environment.

The Fischer **9-pole pos.** connector has all the sensor signals from the 2-component or 3-component sensors integrated in the same connector, and is ideal for applications in a somewhat harsher environment where protection against dust is required.

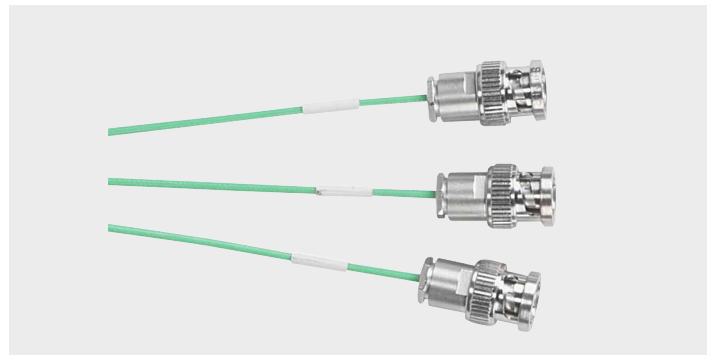



Connector: 3 x BNC pos.



Connector: Fischer 9-pole pos.

## Cable overview for 2-component and 3-component sensors

Sensor family	Cable				
	Technical data	Type	Connector		Length (standard) [m]
			Left	Right	
90x7C / 90x8C 93x7C		1698AA...	V3 pos.	3 x BNC pos.	1 / 2 / 5
93x5B		1698AD...	V3 pos.	2 x BNC pos.	2
90x7C / 90x8C 93x7C		1698AE...	V3 pos.	3 x KIAG 10-32 pos.	10





<sup>1)</sup> Cable cannot be screwed, and must be welded to the sensor as a mandatory requirement

<sup>2)</sup> The steel braiding is torsion-resistant. To ensure a reliable plug connection, 0.5 m should always be added to the length of the cable ordered

	Length (custom) [m]		Cable sheathing material	Operating temperature range [°C]		Cable can be welded to sensor		Deg. of protection to IEC/EN 60529		Comments
	min.	max.		min.	max.	Yes	No	Left	Right	
	0,2	20	PFA with plastic braiding	-40	120		•	IP65 -> screwed connection	IP40	Standard cable for most applications
	0,2	20	PFA with plastic braiding	-40	120		•	IP65 -> screwed connection	IP40	Standard cable for most applications
	0,2	20	PFA with plastic braiding	-40	120		•	IP65 -> screwed connection	IP65	Standard cable for most applications



# Accessories

## Couplings

Type		Connector	
		Left	Right
1701		BNC neg.	BNC neg.
1705		BNC pos.	M4x0,35 neg.
1721		BNC pos.	KIAG 10-32 neg.
1729A		KIAG 10-32 neg.	KIAG 10-32 neg.
1733		BNC pos.	Banana jacks
1743		BNC pos.	2 x BNC neg.
1749		KIAG 10-32 pos.	2 x KIAG 10-32 neg.
1700A29		KIAG 10-32 neg.	KIAG 10-32 pos. int.
1703		BNC neg.	BNC neg.
1713		TNC neg.	TNC neg.
1723		TNC pos.	KIAG 10-32 neg.
1711		TNC neg.	TNC neg.





## Plastic protective caps

Type		To be used for
1851		BNC neg.
1861A		BNC pos.
1891		KIAG 10-32 neg.

The plastic protective caps reliably protect the connectors and sockets against contamination. If sensors or charge amplifiers are not being used or are in storage, it is always advisable to protect the connectors with protective caps.

## BNC cable, high-insulation

Type Type XXX...	Connector		Length (standard) [m]	Length (custom) [m]		Cable sheath material	Operating temperature range [°C]		Deg. of protection to IEC/EN 60529	
	Left	Right		min.	max.		min.	max.	Left	Right
1601B... 	BNC pos.	BNC pos.	0,5 / 1 / 2 / 5 / 10 / 20	0,1	50	PVC	-25	70	IP40	IP40
1603B... 	BNC neg.	BNC pos.	2 / 5 / 10 / 20 / 50	0,1	50	PVC	-25	70	IP40	IP40

## Charge attenuators



Technical data	Type	5361A...
Attenuation ratio	n	acc. to choice: 2:1 / 5:1 / 10:1 / 20:1 / 100:1 / 200:1 / 1000:1
Insulation resistance	$\Omega$	$>10^{14}$
Charge input	X	BNC neg.
Charge output	X	BNC pos.
Dimensions (W×H×D)	mm	57×29×35 (without connector)

In force sensors with a very wide force range, the charge produced by the sensor may exceed the maximum charge permitted by the charge amplifier input. In such cases, a charge attenuator can be connected between the sensor and the charge amplifier so the charge present on the amplifier is reduced. The charge is reduced by the attenuation ratio n.

# Charge amplifier technology

The charge produced by a piezoelectric sensor is a variable that is difficult to access for measurement. For this reason, electronics are connected downstream of the sensor to convert the charge signal into a voltage signal.

A charge amplifier, as this device is known, converts the negative charge produced by the piezoelectric sensor when it is subjected to loading by a force into a positive voltage that is proportional to the charge or the acting force. Due to their principle of operation, force sensors have negative sensitivity and they produce a negative charge under load.

The next illustration shows the circuit diagram for a charge amplifier, with its three main components:

- Range capacitor  $C_r$
- Time constant resistor  $R_t$
- Reset/Measure switch

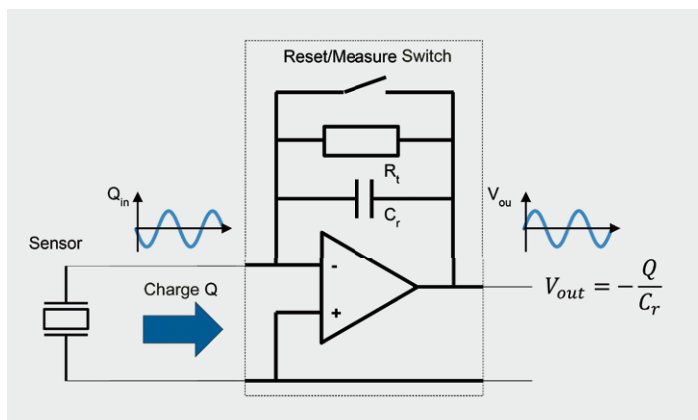

Circuit diagram of a charge amplifier

The **range capacitor  $C_r$**  is used to set the measurement range of the charge amplifier. This is done by switching between different range capacitors. Switching measurement ranges makes it possible to measure across several decades with an outstanding signal-to-noise ratio. Hence, for example, it is possible to use the same force sensor to measure forces in the 100 kN range and in the 100 N range, simply by switching the measurement range. Furthermore, the signal-to-noise ratio is excellent in both ranges.

The **time constant resistor  $R_t$**  defines the time constant of the charge amplifier. Considered in the frequency range, the time constant determines the cut-off frequency for the high-pass characteristic of the charge amplifier. Switching between different time constant resistors makes it possible to change the high-pass characteristic.

The **Reset/Measure switch** is used to control the start of measurement or to set the zero point.

## Selection criteria for charge amplifiers

Various criteria determine the choice of a charge amplifier that is suitable for the application. The product overview on page 6 shows a selection of suitable charge amplifiers with all the criteria. The most important selection criteria for choosing a suitable charge amplifier are as follows:

- Number of channels
- Measurement range
- Measurement type
- Frequency range

The following sections give more detailed explanations of the 'measurement type' and 'frequency range' selection criteria.

## Measurement type – quasi-static versus dynamic measurement

A distinction is made in piezoelectric measurement technology between quasi-static and dynamic measurements. Most charge amplifiers support both types of measurement, but there are some amplifiers that only permit one of the two measurement types. For this reason, it is critically important to have a clear understanding of the type of measurement that should be used for the specific measurement task.

The measurement type determines the behavior of the charge amplifier in the lower frequency range, and is influenced by a key component of the charge amplifier: the time constant resistor, or the time constant. The time constant determines the cut-off frequency for the high-pass characteristic of the charge amplifier, so it also determines the measurement type.

### Time constant

The next table shows the influence of the measurement type and/or the time constant on the behavior of the charge amplifier in the frequency and time range.

The time constant determines the cut-off frequency of the high-pass characteristic, or the behavior of the charge amplifier in the lower frequency range.

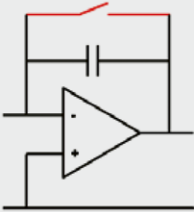
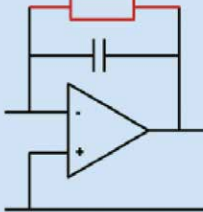
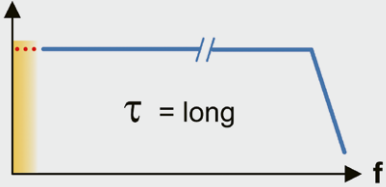
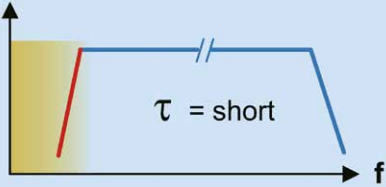
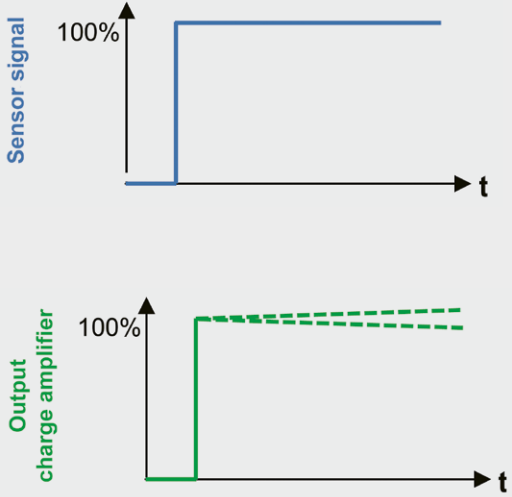
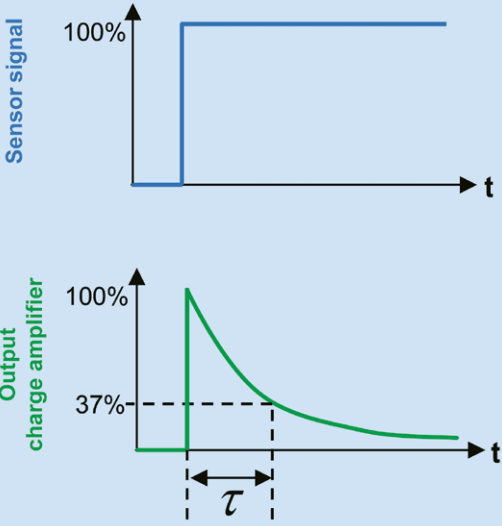
Quasi-static measurement	Dynamic measurement
	
<ul style="list-style-type: none"> <li>• Time constant 'long' (no time constant resistor)</li> <li>• Behavior is comparable to DC mode on the oscilloscope</li> </ul>	<ul style="list-style-type: none"> <li>• Time constant 'short' (with time constant resistor)</li> <li>• Behavior is comparable to AC mode on the oscilloscope</li> </ul>
<ul style="list-style-type: none"> <li>• Behavior in the frequency range:</li> </ul> 	<ul style="list-style-type: none"> <li>• Behavior in the frequency range:</li> </ul> 
<ul style="list-style-type: none"> <li>• Behavior in the time range:</li> </ul>  <p data-bbox="110 1707 808 1770">-&gt; Drift caused by the operating principle becomes visible in case of longer measuring times</p>	<ul style="list-style-type: none"> <li>• Behavior in the time range:</li> </ul>  <p data-bbox="829 1707 1518 1770">-&gt; No drift due to the time constant</p>

Applications where a static force has to be measured over a lengthy period therefore require a charge amplifier that supports quasi-static measurement (time constant 'long').

**Reset/Measure**

Due to its principle of operation, piezoelectric measurement technology does not permit measurements with an absolute zero point reference. For a quasi-static measurement, the zero point is defined on starting the measurement, and starting is controlled by the Reset/Measure switch. For a dynamic measurement, however, it is not possible to set a zero point because measurements are made without a zero point reference on account of the time constant.

The next table shows the behavior of the charge amplifier as regards the Reset/Measure switch for the two types of measurement.

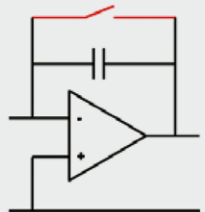
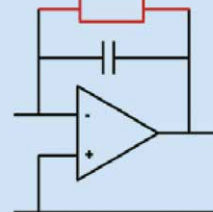
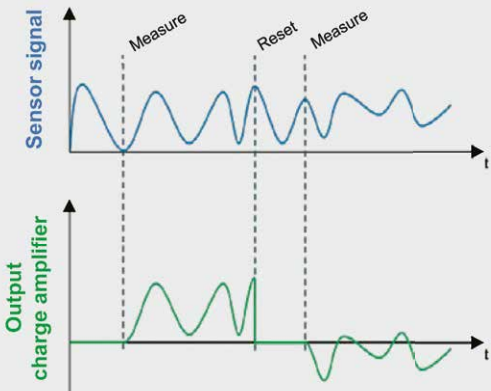
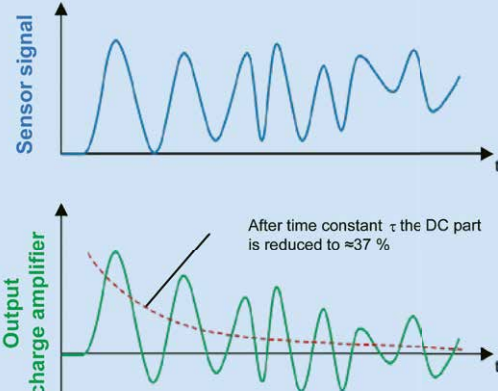
Quasi-static measurement	Dynamic measurement
	
<ul style="list-style-type: none"> <li>• Zero point is set on starting the measurement</li> <li>• Start of measurement is controlled by the Reset/Measure switch</li> </ul>	<ul style="list-style-type: none"> <li>• Measurement without zero point reference, due to the time constant</li> <li>• No Reset/Measure signal is needed, or the charge amplifier is always operated in Measure mode</li> </ul>
<ul style="list-style-type: none"> <li>• Behavior in the time range:</li> </ul> 	<ul style="list-style-type: none"> <li>• Behavior in the time range:</li> </ul> 

## Frequency range

The frequency range of a charge amplifier is defined by the lower and upper cut-off frequencies. The lower cut-off frequency is defined by the measurement type (quasi-static or dynamic), which determines the high-pass characteristic. The upper cut-off frequency is defined by the low-pass which is a feature of all charge amplifiers due to system-related reasons. Consequently, the upper cut-off frequency is only dependent on the design of the charge amplifier, but not on the measurement type.

There are virtually no application cases in force measurement technology where the upper cut-off frequency of the charge amplifier is a limiting factor. In most force applications, the natural frequency is in the range up to 10 kHz. An upper cut-off frequency for the charge amplifier in the 20 to 40 kHz range is therefore perfectly adequate for most applications.

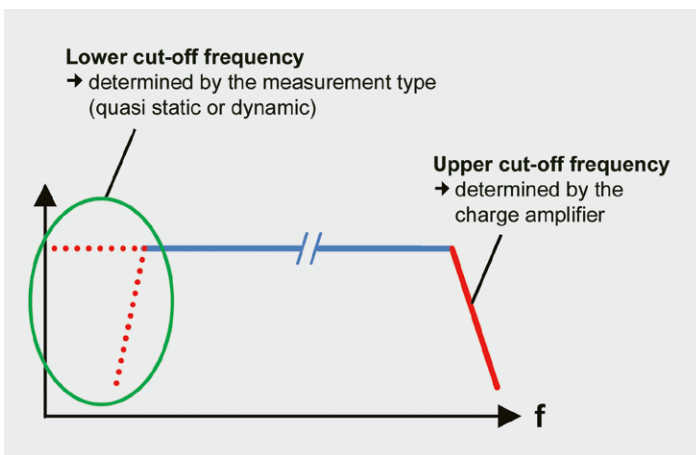

Frequency range: charge amplifier

## Measurement signals and suitable measurement types

The next table shows the behavior of the charge amplifier for quasi-static and dynamic measurements, with the help of some typical examples of measurement signals encountered in force measurement technology. The examples are intended to assist you with the choice of the right measurement type for the specific measurement assignment.

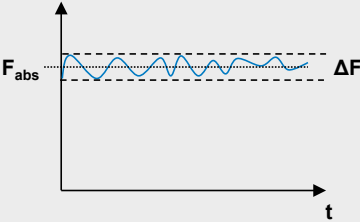
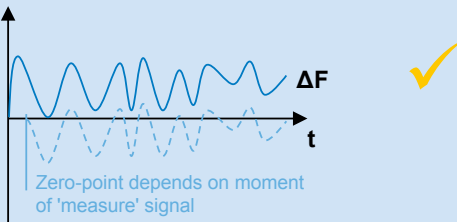
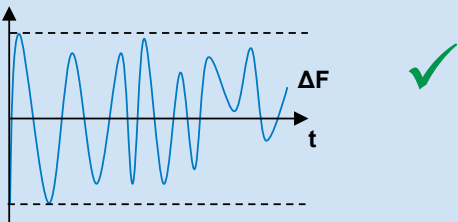
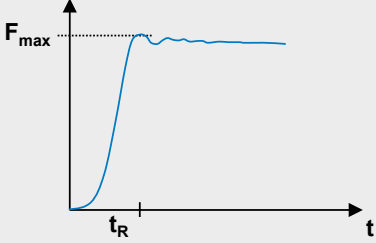
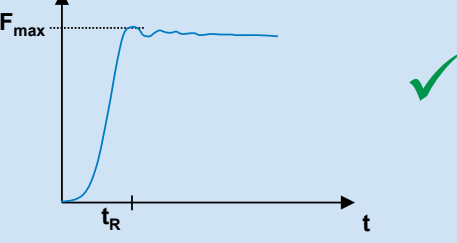
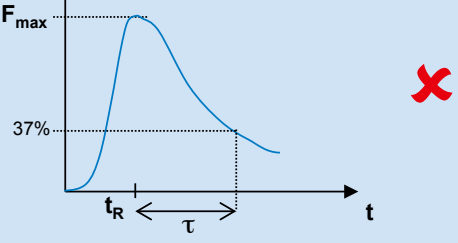
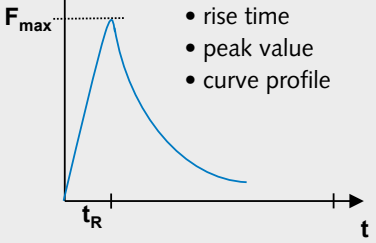
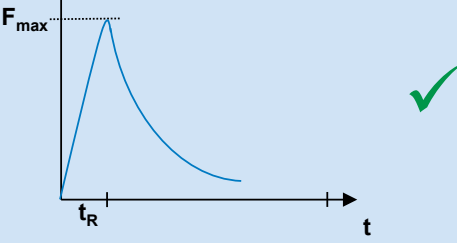
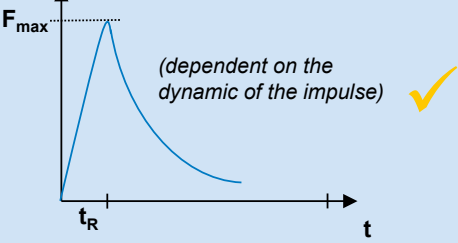
Physical force signal	Charge amplifier output	
	Quasi-static measurement -> 'Long' time constant	Dynamic measurement -> 'Short' time constant
<p>Small force signal with large static preload (<math>F_{abs} \gg \Delta F</math>)</p> 		
<p>Rapid increase in force to static level</p> 		
<p>Rapid force pulse Of interest:</p> <ul style="list-style-type: none"> <li>• rise time</li> <li>• peak value</li> <li>• curve profile</li> </ul> 		

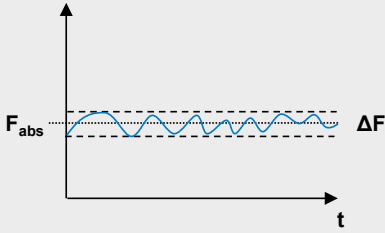
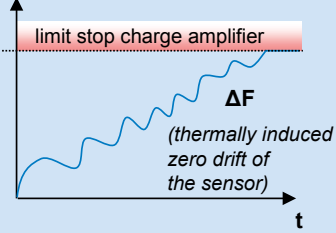
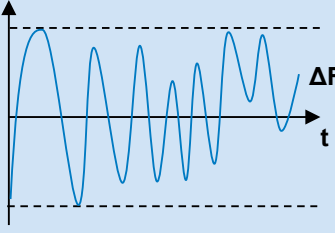
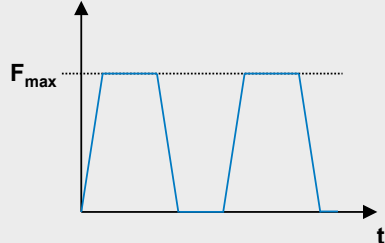
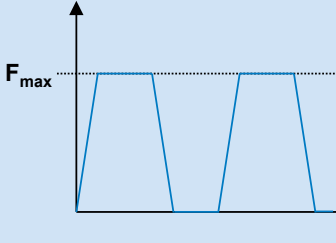
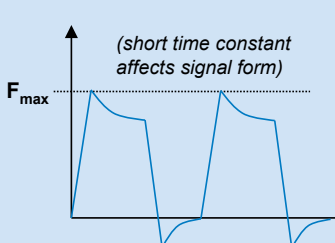

Physical force signal	Charge amplifier output	
	Quasi-static measurement -> 'Long' time constant	Dynamic measurement -> 'Short' time constant
Long measurement time and temperature change 		
Trapezoid force signal 		

Suitability of measurement type

- ✓ = ideal
- ✓ = restricted
- ✗ = unsuitable



From professional advice on installation to speedy deliveries of spare parts: Kistler's comprehensive range of services and training is at your disposal across the globe.

## Service: Customized solutions from A to Z

Kistler offers sales and service wherever automated manufacturing processes take place.

In addition to sensors and systems, Kistler offers a host of services – from professional advice on installation to speedy worldwide deliveries of spare parts. For an overview of the services we offer, visit: [www.kistler.com](http://www.kistler.com). For detailed information on our training courses, please contact our local distribution partners (see page 35).

### Kistler service at a glance

- Consulting
- Support with system commissioning
- Process optimization
- Periodic on-site calibration of sensors in use at customers' premises
- Education and training events
- Development services

# At our customers' service across the globe

Thanks to Kistler's global sales and service network, we are always close to our customers. Approximately 1860 employees at 58 locations are dedicated to the development of new measurement solutions and offer customized on-site support of individual applications.



**Data sheets and documents**  
Use our Online Search to download data sheets, brochures or CAD data.



**Our representatives are here to help**  
Whether you would like a consultation or require support during installation – our website provides the contact information for your local representative.

Home Contact Jobs Newsletter Switzerland Select Country English Select Language Login

Search... SEARCH

**Applications Products Services Career About us**

Home

**The targeted approach to boosting engine efficiency**

**KISTLER**  
measure. analyze. innovate.

- Automotive Research & Test
- Industrial Process Control
- Sensor Technology

**Kistler – Measuring Systems and Sensors**

The Kistler Group is the global market leader in dynamic measurement technology. With – and for – our customers, we develop technology-based measuring solutions that push the physical limits, as we work together to break new ground: Kistler, for measuring systems and sensors that meet extreme challenges.

Our technology measures pressure, force, acceleration and torque. Our instruments are used to measure and analyze physical processes, control industrial processes and optimize products. Our product offering is used in engine development and monitoring, vehicle technology, plastics processing and metal machining, as well as assembly and testing technology. We develop and supply sensors, electronics, and software, backed up by a full range of services. In short: everything from one single source.

**NEWS**

**Kistler presents new measurement technologies at the Automotive Testing Expo 2017** 02.05.  
Kistler presents innovative measurement equipment for demanding vehicle testing applications

**Kistler showcases practical sensor integration for injection molds** 25.04.  
At Moulding Expo 2017, we will show how easy it is to install the measurement



**Education and training events**  
Education and training courses, during which our sensors and measuring systems are explained by Kistler experts, are the most efficient way for you to obtain the required user knowledge.

Find out more about our applications:  
[www.kistler.com/applications](http://www.kistler.com/applications)

**Force Sensors**  
Improve productivity, high precision  
Process Quality and Reduce Costs.

**NC Joining Systems**  
Solutions for Energy Efficient and highly Flexible Press Fit and  
Joining Processes.

**Process Monitoring Systems**  
maxIMOS RT Monitor for 100% Quality  
in Production, Assembly and Product Testing.

**Kistler Group**  
Eulachstrasse 22  
8408 Winterthur  
Switzerland  
Tel. +41 52 224 11 11

Kistler Group products are protected by several intellectual property rights. For more details see [www.kistler.com](http://www.kistler.com).  
The Kistler Group includes Kistler Holding AG and all its subsidiaries in Europe, Asia, the Americas and Australia.

Find your local contact on  
[www.kistler.com](http://www.kistler.com)

**KISTLER**  
measure. analyze. innovate.