

**Reduce costs  
with closed-  
loop combustion  
control**

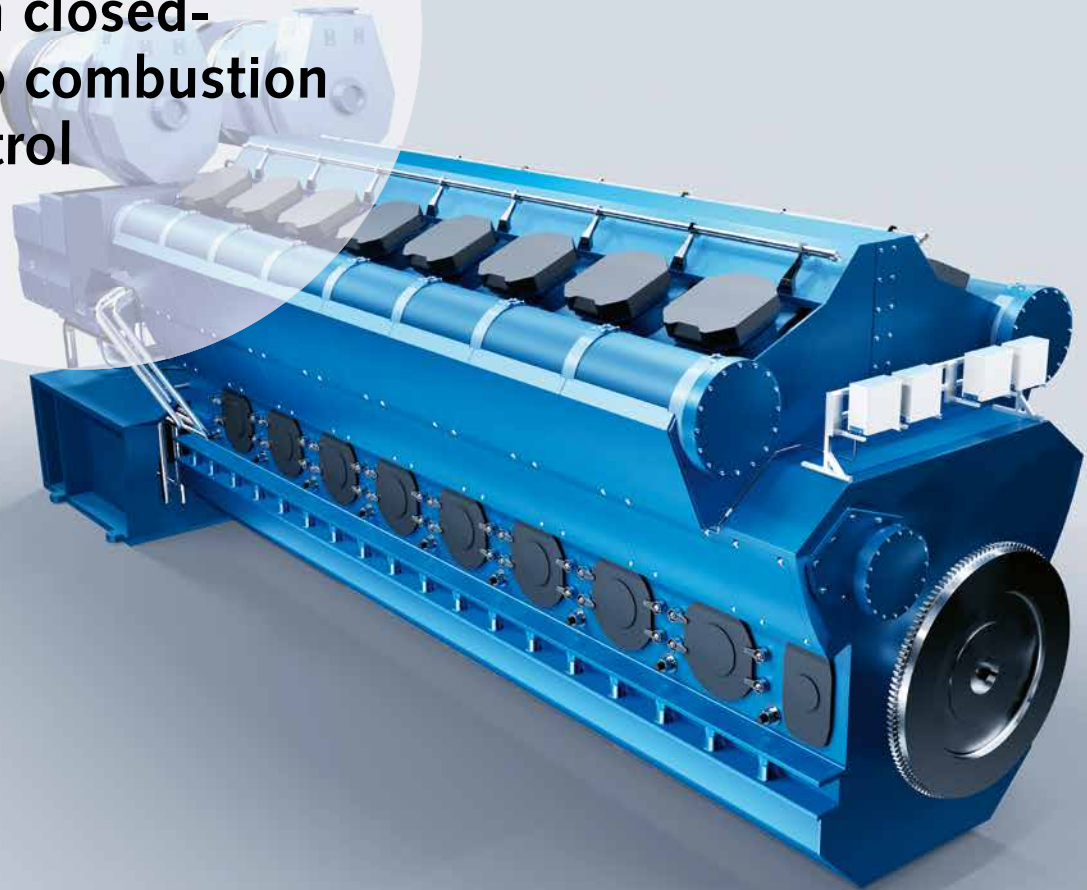

## **Marine & Stationary**

Reliable efficiency improvements with combustion monitoring and control in large engines with sensor technology from Kistler



**Kistler – Your partner for process efficiency and cost effectiveness**

The Kistler Group is one of the world's leading manufacturers of sensors and systems for measuring pressure, force, torque and acceleration. Kistler systems are used to analyze measuring signals with high-precision in order to substantially increase process efficiency and operational success.



For the last 25 years, Kistler wheel force sensors have been setting standards when it comes to measuring durability. Customers across the globe appreciate the unique precision and quality of Kistler's sensor technology for road load and test bench applications alike.



Kistler delivers complete systems for high-precision measurements of longitudinal and transverse dynamics in mobile vehicle testing.



Vehicle tires have to meet ever-increasing demands – so requirements for test methods and the measuring systems used for them are becoming stricter. Multi-component measuring hubs on the test bench or RoaDyn wheel force sensors and Correvit sensors on the test track deliver precise test results.

# Editorial



Now that about 25 years have passed since the start of globalization, one thing is clear: it's essential for all players in industry and business to take an active role in continuing to develop existing technologies and expanding specialist know-how. This is the only way to reconcile the requirements of a globally interconnected economy with the need to keep the environment intact.

In the marine and stationary engine segment, we are proud to play our part by responding consistently to the market's needs with new and efficient solutions. Dependable products that ensure high

operational reliability, and our constant striving for technical excellence: based on these cornerstones, we are still setting standards in sustainable resource optimization. Our commitment goes well beyond the development of durable, energy efficient sensors and systems to optimize large engines. As a division of the Kistler Group, we offer professional advice and Kistler's worldwide service as part of our daily endeavor to boost your company's business success over the long term!

Jürg Stadler,  
Head of Strategic Business Field  
Engine Research & Development/Engine  
Marine & Stationary

## Contents

### Introduction

Sensor and system expertise – from one single source 4

### Applications

Continuous monitoring 6

Offline engine diagnosis 8

### Product portfolio

The right sensor for your application 10

### Service

Kistler – Your partner for innovation 14

Worldwide presence for our customers 15



Efficient operation of marine engines with Closed-Loop Combustion Control from Kistler

## Sensor and system expertise – from one single source

**When you need to monitor and control large engines, look no further than Kistler: we offer high-quality cylinder pressure sensors backed by all the service and system expertise you require – so we can develop cost-effective solutions tailored to each customer's specifications.**

### **Trouble-free operation with lower fuel consumption**

Efficient, safe and reliable operation of large marine and stationary engines depends on one critical factor: monitoring and control of cylinder pressure. Optimal adjustment and accurate monitoring of combustion during continuous operation will deliver major benefits: you will make substantial savings on fuel consumption while reducing the risk of breakdowns and premature wear. Sensor technology from Kistler delivers reliable solutions to achieve these goals.

### **Increased efficiency means long returns**

At Kistler, we can draw on our lengthy experience of developing custom solutions for manufacturers of large engines all over the world. Our know-how is recognized by numerous shipbuilders, shipping companies and power plant operators. By drawing on our expertise in sensor technology and our all-round system know-how, we can assist with improving the efficiency of large marine and stationary engines. The basis: cooperation amongst all parties involved. The objective: to develop more cost-effective solutions.





### **Benefits**

#### **Excellent operational reliability**

- Proven, high quality products ensure trouble-free, continuous operation

#### **Technical excellence**

- Repeatable, high resolution cylinder pressure data
- Accurate feedback for optimized combustion
- Customized sensors for any application
- Ideal for engines with multi-/flexible fuel options

#### **Optimized resources**

- Fuel consumption reduction
- Lower emissions
- Reduced service requirements
- High return on capital from long sensor life



Simple handling and first-class results: reliable online monitoring with Kistler pressure sensors

# Continuous monitoring

Rugged piezoelectric cylinder pressure sensors from Kistler are designed to give many years of service providing continuous monitoring of cylinder pressure in internal combustion (IC) engines.

## Closed-Loop Combustion Control (CLCC) for increased efficiency

The continuous monitoring of the cylinder pressure provides the key element to optimize combustion efficiency in any IC engine – feedback control of the actual combustion process. Enabling this, the engine operator gains not just optimized fuel consumption and emissions but also reduced engine wear and the tool to access critical data for preventative maintenance.

## Application areas

Many industries today have to meet ever greater business expectations with stricter regulatory requirements on their engines. The response: more widespread use of cutting-edge engine technology to maximize engine efficiency – with CLCC a highly regarded route to improve efficiency in all industries operating IC engines. The major exceptions to this are in engines where dual fuel or variable fuel quality requires continuous monitoring not just to make efficiency improvements but to ensure engine health under the highly variable combustion regimes these engines can operate in. Leading engine manu-

facturers put their trust in the quality of Kistler's sensors to deliver the combustion data necessary – where data reliability and consistency are high on their list of priorities. Kistler sensors are installed in both two and four stroke applications, operating on diesel, gas or diesel/gas dual fuels, in low and medium speed engines.

### Benefits

- Fuel is saved
- Emissions are minimized
- Wear is reduced
- Servicing intervals are optimized

### Certificates



# Process Closed-Loop Combustion Control

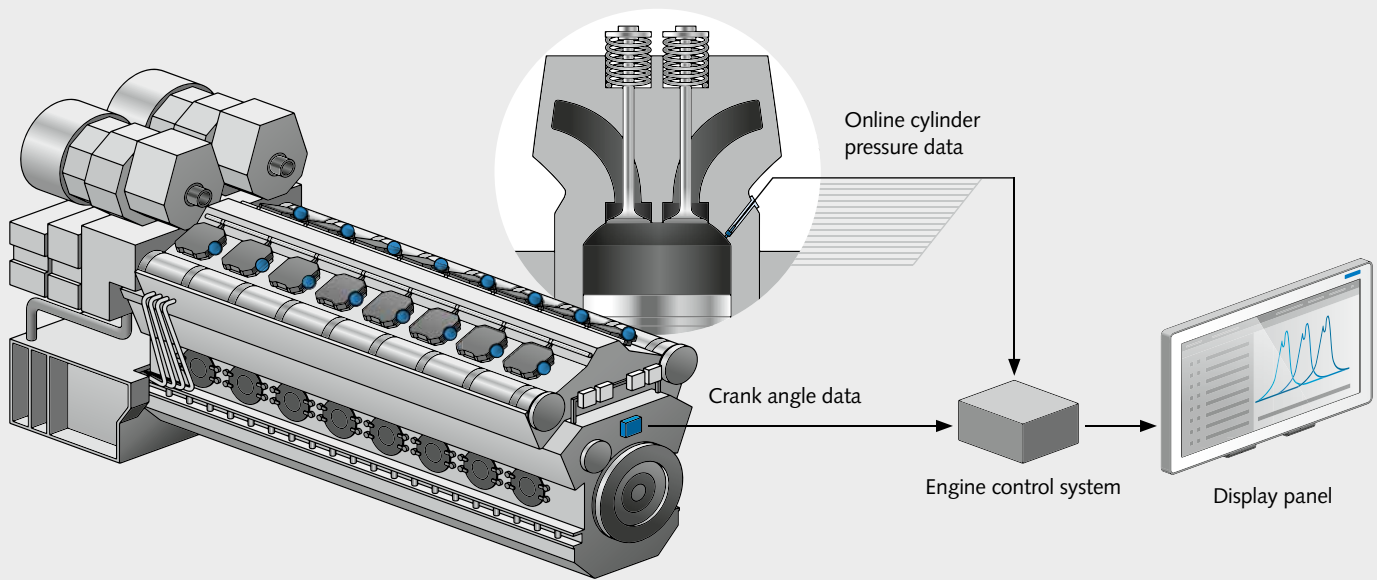

## Closed-Loop Combustion Control – now online

Use our animation to experience convincing, first-class Kistler solutions – the sure way to achieve maximum engine efficiency:  
[www.kistler.com/continuous-monitoring](http://www.kistler.com/continuous-monitoring)





Convenience and precision: within the shortest possible time, this Kistler diagnostic device provides the necessary data as the basis for offline monitoring

## Offline engine diagnosis

**Cylinder pressure is a crucial factor in monitoring low and medium speed combustion engines. The parameter provides meaningful information about the engine's operation. This is why regular cylinder pressure measurement is a standard – and this data provides the essential basis for optimizing fuel consumption.**

**Pressure sensors and diagnostic equipment from Kistler**  
Kistler's diagnostic equipment is the solution of choice for regular recording and evaluation of peak pressures on large engines. Quickly and easily mounted on the indicator valve, these rugged devices deliver accurate and reliable measurement data from sensors with long-term stability. That is why measurement technology from Kistler is also the preferred choice for equipment manufacturers who produce their own diagnostic instruments.

### **Kistler's on-site service**

Safe and reliable operation is the overriding priority for large engines – so our specialists are always standing by to assist you with advice and practical help at any time, anywhere in the world.

### **Benefits**

- Damage is detected at an early stage
- Servicing intervals are optimized
- Emission limits are respected
- Cylinder balancing is simple
- Fuel consumption is optimized



## Process offline engine diagnosis

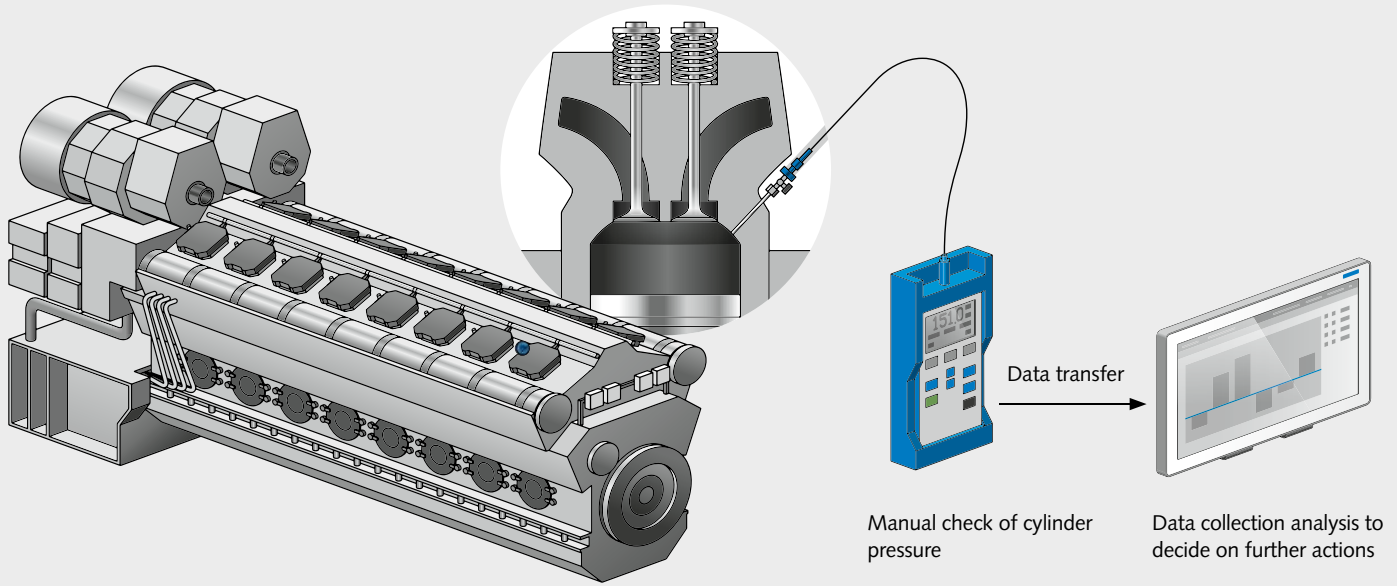

### Offline engine diagnosis – now online

Use our animation to experience convincing, first-class Kistler solutions – the safe way to achieve maximum engine efficiency:  
[www.kistler.com/continuous-monitoring](http://www.kistler.com/continuous-monitoring)





Kistler sensor Type 6613CG2 for Closed-Loop Cylinder Pressure Control

## The right sensor for your application

**Exact, reproducible pressure measurement values can only be obtained with reliable sensors that measure precisely. Piezoelectric sensors from Kistler are rugged and easy to maintain.**

### **Accurate and reliable**

The heart of a Kistler sensor is a specially developed piezoelectric measuring element. This forms the basis for accurate and stable measurement results throughout the whole sensor lifetime, even in demanding environments. Kistler sensors deliver high-precision measurements of pressure variations (range up to 350 bar) and/or temperature changes of up to 350 °C.

### **Fits your unique environment**



The Kistler patented "antistrain" design enables the measuring element to be insensitive to varying mounting conditions – this enhanced flexibility easily allows the integration of the sensors in individual environments.

### **The sensor's lifetime**

Flexible with regard to fuels, the sensor types can be used in gas as well as two- and four-stroke diesel engines.

The sensors are designed for a life of several thousand operating hours in a diesel or gas engine; however the individual sensor life time is strongly depending on the specific application and maintenance.

# Closed-Loop Combustion Control for 2-stroke engines

Technical data		Type 7614CG2	Type 6613CG2
			
Pressure range	bar	0 ... 250	0 ... 250
Linearity	%FSO	<±0.5	<±0.5
Operating temperature range	°C	-40 ... 350	-40 ... 350
Frequency range	Hz	0.01 ... 10 000	0.01 ... 10 000
Signal output		4 ... 20 mA/3 wires galvanic isolated	4 ... 20 mA/3 wires galvanic isolated
Properties		<ul style="list-style-type: none"> <li>• Front end sealing or shoulder sealing</li> <li>• Excellent lifetime</li> <li>• Suitable for knock detection</li> </ul>	<ul style="list-style-type: none"> <li>• Excellent lifetime</li> <li>• Build-up of combustion deposits is reduced in combination with Kistler's patented adapter, Type 7523B...</li> <li>• Suitable for knock detection</li> </ul>
Certificates		GL, ABS, BV, LR, DNV, CCS – Marine type approval and ATEX, IECEx	GL, ABS, BV, LR, DNV, CCS – Marine type approval and ATEX, IECEx
Data sheet		<b>7614CG_003-044</b>	<b>6613CG_003-043</b>

For direct installation in cylinder cover  
Front end sealing or shoulder sealing possible

Vastly reduced build-up of combustion deposits in combination with patented adapter Type 7523B...

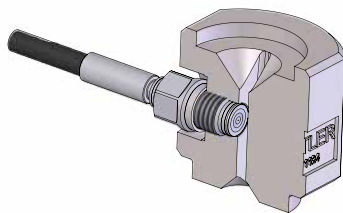

Example of adapter for MAN engines

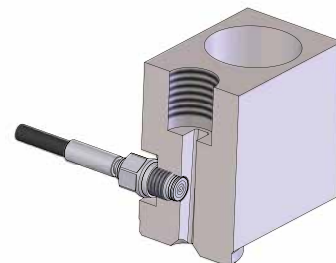

Example of adapter for WinGD engines

## Patented adapter Type 7523B...: Opening up new options for cylinder pressure monitoring

Kistler has developed a special adapter for online sensors. It features a highly specific design of the inner surface that comes into contact with the combustion gases. The special patented geometry of the sensor adapter reduces carbon deposits at the measuring point – so measurement results are constantly stable.

Online sensor mounted in an optimized mounting adapter with a flat inner surface and reduced cross-sectional area.  
US Patent No.: 8,079,252 B2

# Closed-Loop combustion control for 4-stroke engines

Now for up to 350 bar!

Technical data	Type 6635A1
----------------	-------------



**M10 cylinder pressure sensor for 4-stroke engines**  
 Online cylinder pressure sensor with PiezoStar crystal technology enabling long sensor service life. Patented diaphragm design providing maximal strength and minimal thermal shock. New signal transmission system with welded connections and no moving parts ensuring reliable, wear-free signal transmission in harsh environments with high levels of vibration and mechanical shock. The sensor is linked by a robust FPM cable of 1 m length to a charge amplifier. The rugged design and high temperature resistance allow for flush mounting in the cylinder head. The sensor is suitable for knock detection during engine characteristics measurement and for high pressure ranges (350 bar) in 4-stroke medium speed engines.

Pressure range	bar	0 ... 350
Linearity	%FSO	≤±0.75
Operating temperature range	°C	-40 ... 350
Frequency range	Hz	0.016 ... 10 000
Signal output		4 ... 20 mA/3 wires galvanic isolated
Sensitivity		37.0 µA/bar
Certificates		ATEX, IECEx, EU-RO Mutual Recognition
Data sheet		6635A1_003-331



Technical data	Type 7614CG1	Type 6613CG1
----------------	--------------	--------------





Pressure range	bar	0 ... 250
Linearity	%FSO	≤±0.5
Operating temperature range	°C	-40 ... 350
Frequency range	Hz	0.1 ... 10 000
Signal output		4 ... 20 mA/3 wires galvanic isolated
Properties		<ul style="list-style-type: none"> <li>• Front end sealing or shoulder sealing</li> <li>• Excellent lifetime</li> <li>• Suitable for knock detection</li> </ul>
Certificates		GL, ABS, BV, LR, DNV, CCS – Marine type approval and ATEX, IECEx
Data sheet		7614CG_003-044



Pressure range	bar	0 ... 250
Linearity	%FSO	≤±0.5
Operating temperature range	°C	-40 ... 350
Frequency range	Hz	0.1 ... 10 000
Signal output		4 ... 20 mA/3 wires galvanic isolated
Properties		<ul style="list-style-type: none"> <li>• Excellent lifetime</li> <li>• Suitable for knock detection</li> </ul>
Certificates		GL, ABS, BV, LR, DNV, CCS – Marine type approval and ATEX, IECEx
Data sheet		6613CG_003-043



# Instruments for machinery maintenance

<b>Technical data</b>	<b>Type 2516B...</b>
	
<b>Engine peak meter Type 2516B...</b> Type 2516B... supports monitoring of engines with speeds of up to 4 000 min <sup>-1</sup> . The data evaluation software included in the accessories supplied with the Peak Meter provides graphic visualization and recording of following parameters:	
<b>Properties</b>	<ul style="list-style-type: none"> <li>• Maximum peak pressure (pmax)</li> <li>• Minimum peak pressure (pmin)</li> <li>• Average peak pressure (pav)</li> <li>• Standard deviation of the peak pressure (Sdev)</li> <li>• Maximum gradient of the pressure curve (dp/ca)</li> <li>• Speed (r/min)</li> <li>• Current peak-pressure; measuring function unlimited in time (ppeak)</li> </ul>
<b>Data sheet</b>	<b>2516B_000-941, 2516B_000-940</b>

<b>Technical data</b>	<b>Type 6513A</b>	<b>Type 6513AK</b>
		
<b>Thompson adapter</b> The Thompson adapter is a standard tool that fits almost all indicator valve on most engines. It is intended for short-term pressure measurements only. 2-stroke engines: it's recommended to use the sensor with adapter Type 6513A. 4-stroke engines: it's recommended to use the sensor with adapter Type 6513AK, as the higher operating temperature of 4-stroke engines necessitates additional cooling to reduce the temperature of the sensor and maximize the life time.		

<b>Technical data</b>	<b>Type 6019A...</b>	<b>Type 6619AP25</b>	<b>Type 6013CA</b>
  			
Pressure range	bar	0 ... 300	0 ... 250
Linearity	%FSO	<±0.3	<±1
Operating temperature range	°C	-40 ... 350 (max. 400 °C for <10 min)	-40 ... 350
Sensitivity		30 pC/bar	20 pC/bar
Properties	<ul style="list-style-type: none"> <li>• Highest precision available with PiezoSmart extended</li> <li>• Extended temperature range 400 °C</li> </ul> Available adapters: <ul style="list-style-type: none"> <li>• Thompson adapter 6513A</li> <li>• Thompson adapter 6513AK</li> </ul>	<ul style="list-style-type: none"> <li>• Highest precision Piezotron® amplifier integrated</li> <li>• Extended temperature range 400 °C</li> </ul> Available adapters: <ul style="list-style-type: none"> <li>• Thompson adapter 6513A</li> <li>• Thompson adapter 6513AK</li> </ul>	<ul style="list-style-type: none"> <li>• Mounting thread M10×1</li> <li>• Rugged design</li> </ul> Available adapters: <ul style="list-style-type: none"> <li>• Thompson adapter 6513A</li> <li>• Thompson adapter 6513AK</li> </ul>
<b>Data sheet</b>	<b>on request</b>	<b>on request</b>	<b>6013C_000-402</b>



## Kistler – Your partner for innovation

Kistler provides customer support with customized service options available throughout our global service network. Depending on the individual customer situation, Kistler will determine the optimum location to complete the service to best meet customer timing requirements.

### **Recalibration & repair:**

Kistler piezoelectric sensors are market leaders based on their long term stability. However abnormal combustion or extended use can lead to a degradation of the sensors sensitivity. Regular recalibration is recommended – to ensure accurate and reliable measurement results at all times.

### **PMI calibration-box:**

The PMI auto-tuning system installed at MAN ME-engines measure the cylinder pressure with online sensors. For commissioning and regular calibration the Kistler PMI Calibration-Box (consisting of a handheld device and a highly accurate reference sensor) is used. To ensure correct functionality Kistler recommends a recalibration of the device and sensors every 5 years. Efficient engine operation is assured. The proposed time for recalibration is during overhaul.

### **Onsite measurements:**

Outside of basic data retrieval, or automated calibration procedures, analyzing and interpreting the data from cylinder pressure measurements does require a certain level of expertise. Kistler supports your individual measurement questions or a more detailed technical analysis of any engine with experienced professionals and additional rental equipment, for example our portable Combustion Analysis System – the Kistler KiBox.

### **Retrofit and adaptation:**

Existing large diesel/gaseous/multi fuel engines can benefit from the advantages of cylinder pressure monitoring by retrofitting with combustion control technology. Our experts are available to discuss the best technical solution for any specific engine application.

### **Consulting & engineering:**

Experienced Kistler experts can offer guidance and advice at any time. This can range from a customized solution for a specific technical issue to an in-house training session on pressure measurements or combustion control. Kistler has the technical knowledge to assist our customer in finding solutions promptly.



- Sales Center
- ▲ Tech Center
- Production Center

## Worldwide presence for our customers

Wherever engine tests are carried out, Kistler is on hand to offer sensors and systems – backed up by a host of services that range from professional advice and support to calibration and speedy deliveries of spare parts across the globe.

To offer even better technical support, Kistler is setting up Tech Centers throughout the world – delivering exactly the service that our customers expect so they can optimize their testing activities.

Find out more about our applications:  
[www.kistler.com/applications](http://www.kistler.com/applications)

**Kistler Group**  
 Eulachstrasse 22  
 8408 Winterthur Switzerland  
 Phone +41 52 224 11 11

Kistler Group products are protected by various intellectual property rights. For more details visit [www.kistler.com](http://www.kistler.com). The Kistler Group includes Kistler Holding AG and all its subsidiaries in Europe, Asia, the Americas and Australia.

Find your local contact at  
[www.kistler.com](http://www.kistler.com)

**KISTLER**  
 measure. analyze. innovate.