

# WS-8

Central tool plug-in system

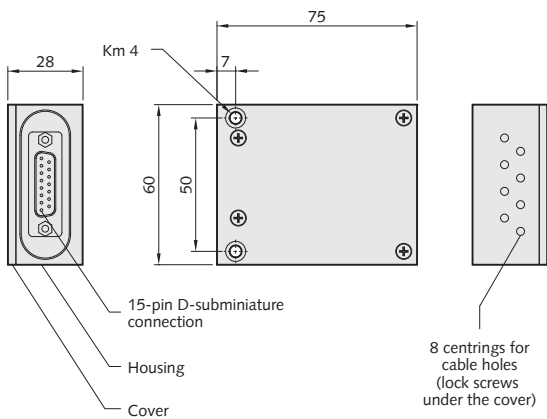

measure. analyze. innovate.



Adapter with 3 x 8-fold terminal for a permanent installation of the sensors used in the stamping tool; a maximum of 8 sensors (light barriers, inductive switches or contact sensors) can be connected.

Connection to the tool control system is made using a 15-pole D-subminiature multipin connection plus a link cable to the workshop adapter of the system.

Especially when using several sensors per tool, the WS-8 adapter can help to realize an elegant and clean solution that will bring huge time advantages with every tool change.

## Cable connection/internal terminal clamps

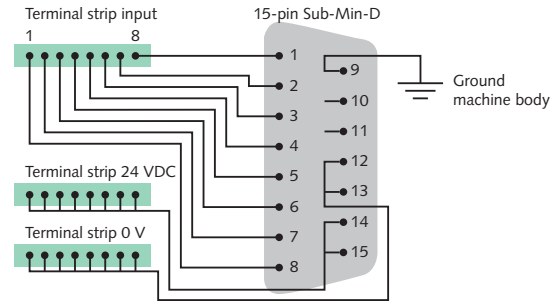

| Article      | Order No.       |
|--------------|-----------------|
| Adapter WS-8 | 2241-08000-1500 |

| Accessories                    | Order No.       |
|--------------------------------|-----------------|
| Connection cable VK-WS-8 (1 m) | 2141-00001-1515 |