

mICA

mICA – miniature Industrial Charge Amplifier with IO-Link

Type 5028A...

The Kistler miniature Industrial Charge Amplifier with IO-Link technology is the smart amplifier for modern industrial applications such as robotics, packaging industry, or food and beverage industry or OEMs. The smart amplifier combines analogue and digital communication technology and paves the road for Industry 4.0.

Most important performance features at a glance:

- fast analog operation with 6.25 kHz bandwidth
- fast IO-Link operation at COM 3
- flexible low-pass filter and applicable high-pass filter
- scaling of analog output from 4% to 100% FS
- invertible reset/operate pin mode
- status LED for device status
- rugged design with IP67 protection
- device core temperature sensor

Description

The Type 5028A... miniature Industrial Charge Amplifier measures the charge signal from the piezoelectric sensor and provides measurement data to the customer system in two different operation modes:

- Analog/Discrete operation
- IO-Link operation

Application

In Analog Mode, the amplifier behaves just as well-known analog charge amplifiers, where reset/operate control is carried out using the digital input pin. Configuration can be done using the IO-Link Interface before final analog installation.

In IO-Link Mode, all communication, configuration and user data is transmitted via the IO-Link Interface, making the device easily applicable for machine and equipment builders. No additional software is required but the already known programming interface of the machine control system, or specific IO-Link Masters used.

Integration into the control environment is carried out as with any other IO-Link device using an IO-Link Master interface by loading the IODD file provided by Kistler.



Technical data

Charge amplifier

Measurement range Type 5028A52x (FSO)	pC max.	±20 ... ±500
Measurement range Type 5028A53x (FSO)	pC max.	±200 ... ±5 000
Measurement range Type 5028A54x (FSO)	pC max.	±2 000 ... ±50 000
Measurement range Type 5028A15x (FSO)	pC max.	±4 000 ... ±100 000
Measurement range Type 5028A55x (FSO)	pC max.	±20 000 ... ±500 000
Measurement error at FSO	% FSO	<±1.0

Drift

25°C, max. relative Humidity RH of 60%, non-condensing	pC/s	<±0.05
50°C, max. relative Humidity RH of 50%, non-condensing	pC/s	<±0.3

Reset-Operate transition error	pC	<±2
Suppression of interference signals between sensor-GND and analog output-GND (0 ... 0.3 kHz)	dB	>50
Max. output voltage range	VDC	±10.3
Frequency range (-3 dB, cable capacity<1 nF)	kHz	±0 ... <=6.25

Operate-Reset time

Q <5 000 pC	us	<50
Q <50 000 pC	us	<500
Q <500 000 pC	ms	<5
Reset-Operate time	ms	<1
Zero-point deviation (Reset)	mV	<±15

5028A_003-477e-08.22

Noise Analog Output (0.1 Hz ... 1 Mhz)	mVpp	<±25
Input-related noise (typ.)		
Derived from the RMS value, 99.9% within, assuming a Gaussian distribution	pC _{pp}	<6.6 x pC _{rms}
Q <500 pC	pC _{rms}	0.038
Q <5 000 pC	pC _{rms}	0.38
Q <50 000 pC	pC _{rms}	3.8
Q < 100 000 pC	pC _{rms}	10
Q <500 000 pC	pC _{rms}	38
Time constant (high-pass filter)		
long (default)	s	>10 000
short	s	60
tolerance short (typ.)	%	10
IO-Link		
Min. cycle time	µs	600
Supported data rates		
COM3	kBaud	230.4
Control voltage		
High	VDC	>12 ... max. 30
Low	VDC	<10 (or open/n.c.)
Pull-down resistor	Ohms	100k ... 250k
Data acquisition		
ADC Resolution	bit	16
Group delay analog signal path (AF-ADC-DAC-AAF)	µs	<90
Low pass filter 2nd Ord. (Type Bessel) cut-off frequency (-3 dB)	Hz	1...6 250 in steps 1/2/5/10 per decade Filter Off = 6 250
Group delay (incl. low-pass filter)		
LP= Off (6 250 Hz)	ms	<0.09
LP = 5 000 Hz	ms	<0.15
LP = 2 000 Hz	ms	<0.2
LP = 1 000 Hz	ms	<0.25
LP = 500 Hz	ms	<0.3
LP = 200 Hz	ms	<0.4
LP = 100 Hz	ms	<0.5
LP = 50 Hz	ms	<1.0
LP = 20 Hz	ms	<1.5
LP = 10 Hz	ms	<2.5

Power supply

Supply voltage	VDC	18 ... 30
Power consumption at 24 V	mA	<50
Overvoltage resistance 40 ms/max	V	55
Galvanic isolation from measuring circuit and digital inputs typ. (not safety relevant)	VDC	<50

Connectors

Sensor charge input	Type	KIAG 10-32 UNF neg.
IO-Link/System	Type	M12x1 4 pole male

General data

Operating temperature range	°C	-20 ... 65
Storage temperature range	°C	-40 ... 85
Vibration resistance IEC60068 Part 2-6 (58 ... 150 Hz constant)	gp	1
Shock resistance IEC60068 Part 2-27 (11 ms)	g	200
Degree of protection as per EN60529 (only with cables fitted and/or covered connectors)	IP	67
Housing material		aluminum passivated
Weight	g	30

Mounting

To mount the amplifier, use the diagonal flange and M3x20 Cylinder Head Screws.

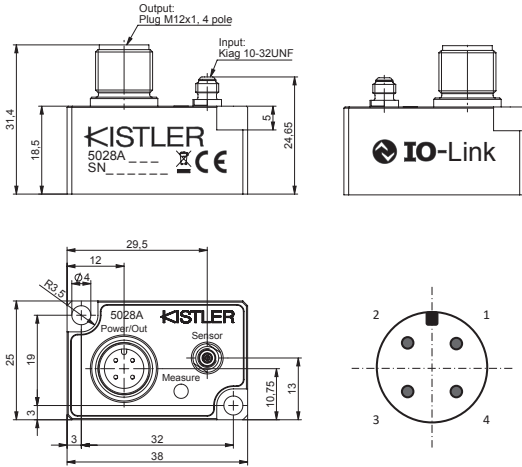

LED	Indication
	Reset: blue blinking 1Hz
	Operate: blue
	Overload: red
	Time constant enabled: green

Fig. 1: Dimensions and LED codes

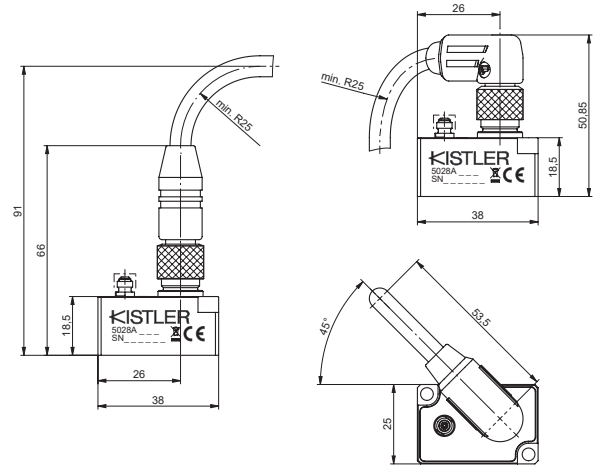

Pin	Function
1	L+ Power Supply Us, +24V
2	Analog Signal Output +/-10V
3	L- Power Supply GND / Signal GND
4	C/Q IO-Link Communication or digital Input: Operate

Fig. 2: Dimensions with cables and amplifier pinout

At any time, the amplifier must be mounted onto a shielding surface, in order to cover the bottom side. Otherwise, electrical fields may influence the signal acquisition part of the amplifier directly.

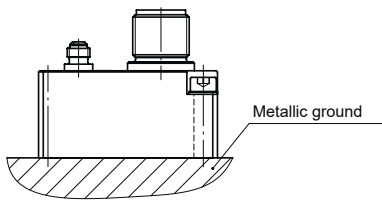

Fig. 3: Mount to GND: Use shielding EMC pad if required (Accessory)

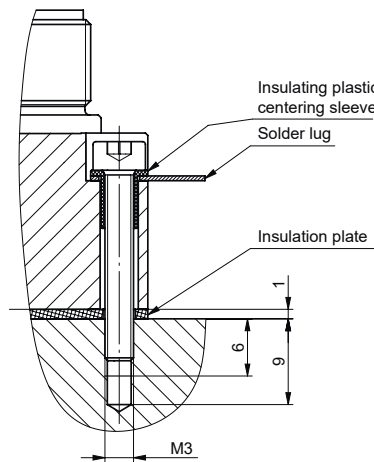
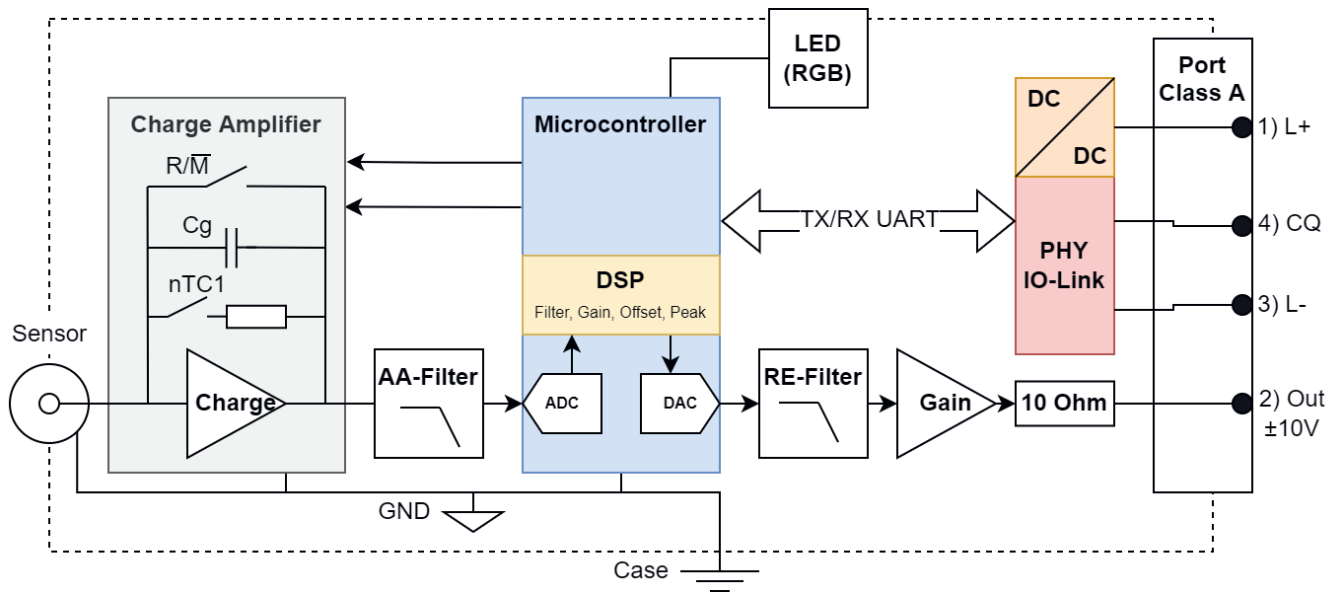

Fig. 4: Insulate from GND if required (Accessory)

5028A_003-477e-08.22

Block Diagram



Cyclic data

Cyclic data according to IO-Link Specification V1.1 Smart Sensor Profile SSP4.3.1:

“Measuring and Switching Sensor, floating point, 1 channel”

PD In (Device to Master) bit 48

Process Data Input structure:

Measurement value (Fraction32bit|Exp.8bit|Sign1bit) | Vendor specific. (8 bit)

PD Out (Master to Device) bit 8

Process Data Output structure:

Vendor specific. (bit 1-7) | Disable (bit 0)

Name	Data Type	Length (Byte)
Measurement Value	Float32T (Fraction32bit Exp.8bit Sign1bit)	4
Vendor Specific	Bitfield	1
	0. Switch Point 1 (Bit0)	
	1. Switch Point 2 (Bit1)	
	2. Operate (Bit2)	
	3. Overload (Bit3)	
	4. Trigger1 (Bit4)	
	(future option)	
	5. Service calibration (Bit5)	
	(future option)	
	6. ... 15. Reserved (Bit6 ... 15)	

Name	Data Type	Length (Byte)
Control	Bitfield	1
	0. Reset (Disable) (Bit0)	
	1. Vendor Specific (Bit1)	
	2. Vendor Specific (Bit2)	
	3. Vendor Specific (Bit3)	
	4. Vendor Specific (Bit4)	
	5. Vendor Specific (Bit5)	
	6. Vendor Specific (Bit6)	
	7. Vendor Specific (Bit7)	

5028A_003-477e-08.22

Acyclic user and configuration data

Parameter name	Parameter Type			Default	IO-Link Index
User Sensitivity	Float (Fraction32bit Exp.8bit Sign1bit)	byte	4	-1	index:256
User Range	Float (Fraction32bit Exp.8bit Sign1bit)	byte	4	500 5 000 50 000 100 000 500 000	index:257
Switch Point 1 Level	Float (Fraction32bit Exp.8bit Sign1bit)	byte	4	0	index:258
Switch Point 2 Level	Float (Fraction32bit Exp.8bit Sign1bit)	byte	4	- User Range Default	index:259
Switch Point Mode	UIntegerT8	byte	1	0	index:260
Operating Hours (ro)	UIntegerT16	byte	2	-	index:261
Low-Pass Filter	UIntegerT8	byte	1	0 – Deact.	index:262
Time Constant	UIntegerT8	byte	1	0 – Deact.	index:263
Temperature Case Actual (ro)	Float (Fraction32bit Exp.8bit Sign1bit)	byte	4	-	index:264
Temperature Case +Max (ro)	Float (Fraction32bit Exp.8bit Sign1bit)	byte	4	-	index:265
Temperature Case -Max (ro)	Float (Fraction32bit Exp.8bit Sign1bit)	byte	4	-	index:266
Measure High or Low Active	UIntegerT8	byte	1	0	index:267
Switch Point Hysteresis	Float (Fraction32bit Exp.8bit Sign1bit)	byte	4	0	index:268
Product Type (ro)	Ostring	byte	15	-	index:269
Calibration Date (ro)	Ostring	byte	15	-	index:270
Units	UIntegerT8	byte	1	M.U.	index:271
Range Analog Output	Float (Fraction32bit Exp.8bit Sign1bit)	byte	4	10	index:272
Reset to Measure Jump Correction	UIntegerT8	byte	1	0 – Deact.	index:273
Corresponding Output Voltage (ro)	Float (Fraction32bit Exp.8bit Sign1bit)	byte	4	-	index:274

Included Accessories

- Protection cap IP54 for KIAG 10-32 UNF **Type/Mat. No.** 1891

Optional Accessories

- Sensor cable PFA, IP65 **Type/Mat. No.** 1635Cxxx
 - plug KIAG 10-32 UNF pos.
 - plug KIAG 10-32 UNF pos.
- Sensor extension cable PFA, IP65 **Type/Mat. No.** 1637Cxxx
 - socket KIAG 10-32 UNF neg.
 - plug KIAG 10-32 UNF pos.
- Metal braided sensor cable PFA, IP65 **Type/Mat. No.** 1900A21Ax
 - plug KIAG 10-32 UNF pos.
 - plug KIAG 10-32 UNF pos.
- Shielded protection cap with O-ring, IP67 for sensor connector (set of 4) **Type/Mat. No.** 1891A1
- Sensor/Actuator cable 3-pole, plug M12 A-coded straight female, to plug M12 A-coded straight male, for robotics, drag chain and welding applications
 - length 1.5 m **Type/Mat. No.** 1700A127A1,5
 - length 3 m **Type/Mat. No.** 1700A127A3
 - length 5 m **Type/Mat. No.** 1700A127A5
 - length 10 m **Type/Mat. No.** 1700A127A10
- Sensor/Actuator cable 4-pole, shielded plug M12 A-coded straight female, to open end for drag chain applications
 - length 3 m **Type/Mat. No.** 1700A129A3
 - length 5 m **Type/Mat. No.** 1700A129A5
 - length 10 m **Type/Mat. No.** 1700A129A10
- Sensor-/Actuator cable, 4-pol., shielded plug M12 A-coded straight female, to plug M12 A-coded straight male, for drag chain applications
 - length 0.6 m **Type/Mat. No.** 1700A131A0,6
 - length 1.5 m **Type/Mat. No.** 1700A131A1,5
 - length 3 m **Type/Mat. No.** 1700A131A3,0
 - length 0.2 ... 20 m **Type/Mat. No.** 1700A131Aasp
- Ground insulation kit **Type/Mat. No.** 65013706

Ordering key

Charge amplifier type

Type 5028A *

Range	
±20 pC ... ±500 pC	52
±200 pC ... ±5 000 pC	53
±2 000 pC ... ±50 000 pC	54
±4 000 pC ... ±100 000 pC	15
±20 000 pC ... ±500 000 pC	55

Ground concept	
Standard (non-insulated version)	1

* Q/Y- Modification options, realization on request only

Ordering example with 6800 pC required range:

5028A541 (2 000 pC ... 50 000 pC, Standard Version)