

Piezoelectric force sensors

Piezoelectric ring force transducers for tensile and compression forces from 20 kN to 700 kN

Types 9101C, 9102C,
9103C, 9104C,
9105C, 9106C, 9107C

Piezoelectric force sensors, also known as piezoelectric ring force transducers, for precise measurement of tensile and compressive forces in highest resolution.

The force sensors are thoroughly tested, but are delivered without calibration certificate and must be calibrated on site **after** installation.

- Thoroughly tested, delivered without calibration certificate
- Linearity including hysteresis $\leq \pm 1.5\%$
- Extremely high stiffness
- Very compact design
- Extremely low threshold
- Degree of protection: IP68, dependent on cable
- Operating temperature range -40 ... 120°C
- No aging, unlimited service life

Description

The 910x family is a piezoelectric (PE) sensor series for force measurement in the z-direction. The force to be measured is transmitted directly to the quartz element located within the sensor. When subjected to a mechanical load, quartz produces an electric charge that is proportional to that load. An outstanding property of quartz is the very low threshold, resulting in a high sensor sensitivity which is extremely linear over the entire measuring range. Thus the behaviour in a certain measuring range is practically identical for all PE sensors, independent of their size.

This has three unique advantages:

- **Overload protection:** Even very small forces can be measured with a sensor with a large measuring range, so that overload protection can be considered without loss of signal quality.
- **High stiffness:** To achieve a construction that is as stiff as possible, a larger sensor can also be used without negatively impacting the quality of the measurement signal.
- **Grouping:** Multiple sensors can simply be added together by electrically connecting them in parallel to a single charge amplifier. The output voltage is then proportional to the sum of all acting forces.

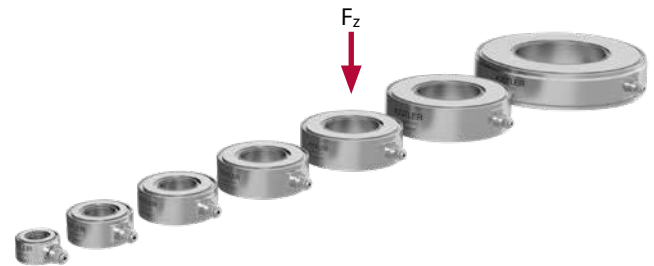

Types 9101C ... 9107C

Application

For monitoring tasks, force sensors are required that can be easily installed in a machine structure. Robust design and reliability in continuous operation as well as good repeatability of the measured values are further features of these sensors. The choice of a certain size depends on the installation space available on the one hand and on the force shunt ratio of the installation on the other hand.

Application examples

- Monitoring of press-in forces during assembly, testing, etc.
- Monitoring of forces during punching and forming
- Measurement of large forces in force shunt

Sensor Mounting

Ring force transducers are generally used preloaded in a mounting structure.

Details about piezoelectric sensors and their installation can be found in the corresponding user's manual on our homepage www.kistler.com/force.

Technical data

--> to ensure the specifications, the sensors must be operated and tested with 20% preload

Type		9101C	9102C	9103C	9104C	9105C	9106C	9107C
Nominal force	kN	20	50	100	140	190	330	700
Load limit	kN	25	60	120	160	210	360	770
Sensitivity	pC/N	-4.4 ±0.3						
Linearity incl. hysteresis	%FSO	±1.5						
Repeatability	%	0.07	0.02	0.04	0.04	0.05	0.04	0.02
Reproducibility	%	0.25	0.10	0.10	0.12	0.13	0.11	0.04
Axial stiffness	kN/μm	1.6	3.3	5.2	7.5	9.8	15.4	27.7
Lateral stiffness ¹⁾	kN/μm	0.31	0.74	1.3	1.8	2.4	3.9	7.6
Shear stiffness	kN/μm	0.40	0.88	1.5	2.2	2.8	4.6	9.0
Torsional stiffness	Nm/°	385	1 955	4 935	10 268	18 469	47 184	190 330
Bending stiffness	Nm/°	388	2 016	5 183	11 228	20 822	55 355	216 950
Maximum bending moment ²⁾ (M _z = 0), calc.	N·m	22	86	217	379	618	1 318	4 229
Temperature sensitivity change (-40°C ... 120°C, T _{ref} = 25°C)	%	±1.5						
Operating temperature range	°C	-40 ... 120						
Insulation resistance (@23°C)	Ω	≥ 5·10 ¹³						
Threshold	N	<0.01						
Capacitance	pF	17±2	33±4	52±5	70±6	93±6	149±15	303±20
Sensor material								
Cover plate		1.4821						
Coat		1.4542						
Connector type		KIAG 10-32 neg.						
Degree of protection (IEC 60529)	IP	check table on page 4						
Weight	g	7	20	36	70	80	157	370

¹⁾ Resistance of the sensor to shear and bending deformation. (Theoretical) assumption: The sensor is fixed at the bottom, the shear force acts at the top, so that the lever length is equal to the total sensor height.

²⁾ With a pretension of 50% of the **nominal force**

Dimensions Type 9101C ... 9107C

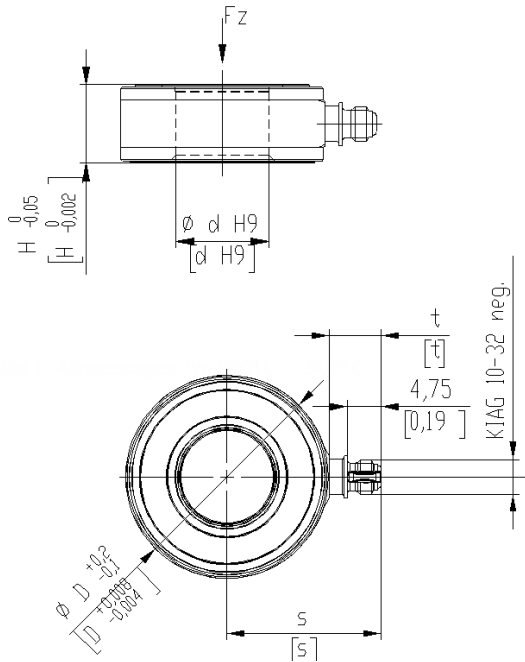

Fig. 1: Dimensions Type 9101C ... 9107C

Dimensions metric [mm]

Typ	d	D	H	s	t
9101C	6.5	14.5	8	14.85	7.25
9102C	10.5	22.5	10	18.6	7.25
9103C	13	28.5	11	21.65	7.25
9104C	17	34.5	12	24.65	7.25
9105C	21	40.5	13	27.65	7.25
9106C	26.5	52.5	15	33.65	7.25
9107C	40.5	77.2	17	45	6.75

Pretension

Piezoelectric force sensors are always used preloaded in a mounting structure. In general, a preloading force of at least 20% of the nominal force is recommended. The recommended, effective measuring range is thereby achieved and the non-linearities in the lowest load range are eliminated.

Reasons for the pretension:

- Highest level of linearity and stability
- Measurement of tensile and compression forces
- Use of the high sensor stiffness for a large frequency range
- Ideal force distribution

The pretension must be selected so that the sum of preloading force (F_V) and the process force ($\pm F_z$) lies within the measuring range of the sensor at all times (see graphic).

Provided it is technologically possible, the average loading of the sensor should be 50% of the nominal force. At this set point, the tolerance with respect to the bending moment is at its greatest (see below, "bending moment").

When pretensioning, the force must be measured with the sensor itself. The sensitivity specified in the technical data is to

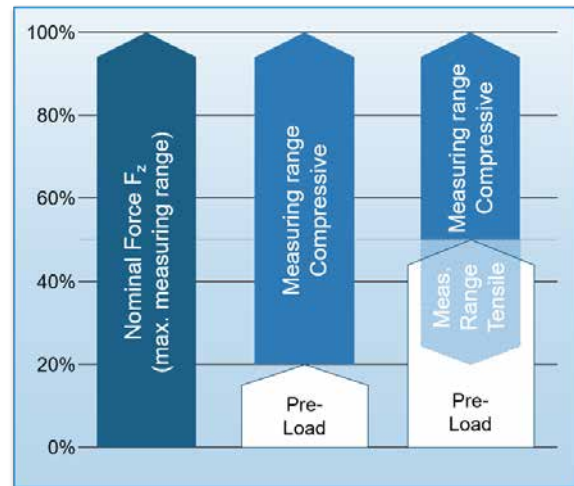

Fig. 2: Nominal and measuring ranges

be used here. The mounting surfaces must be flat, stiff and, if possible, ground. Please refer to the user manual for further details.

9101C_003-473e-08.21

Bending moment

Bending moments M_B ($M_x + M_y$) increase the stress on one side of the sensor and decrease it on the other. This results in an uneven distribution of the axial force on the sensor, that can distort the measuring results.

In extreme cases, this can lead to a one-sided overload of the sensor or loss of the frictional connection, which can destroy the structure or cause it to slip. It ultimately depends on the applied axial force F_z which of the two cases occurs first in the event of an impermissible bending moment.

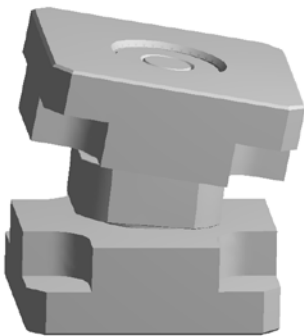

Fig. 3: Bending moment

We use a normalized formula to calculate the allowable bending moment.

$$M_B[\%] \leq 100\% - 2x |50\% - F_z[\%]|$$

F_z is the total axial force on the sensor, so the sum of the preload F_v and the process force F_p .

Bending moment graph

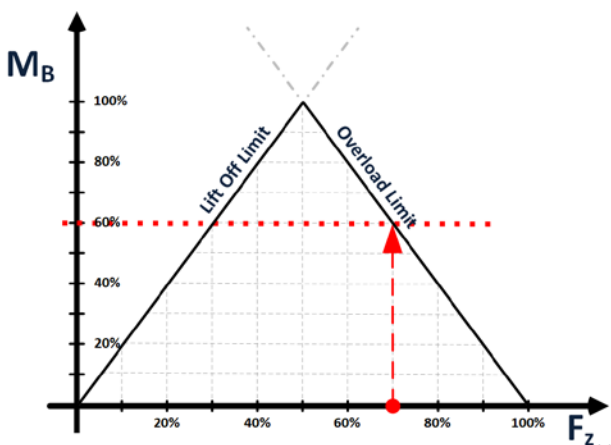

Fig. 4: Bending moment as a function of the axial force F_z

Example

A piezo sensor Type 9103C... is preloaded with $F_v = 28$ kN. What bending moment can be tolerated for process forces in the range $F_p = 0 \dots 33$ kN?

$$F_v[\%] = \frac{28 \text{ kN}}{100 \text{ kN}} = 28\%$$

$$F_p[\%] = \frac{0 \text{ kN}}{100 \text{ kN}} \dots \frac{33 \text{ kN}}{100 \text{ kN}} = 0 \dots 33\%$$

$$F_z[\%] = F_v[\%] + F_p[\%] = 28 \dots 61\%$$

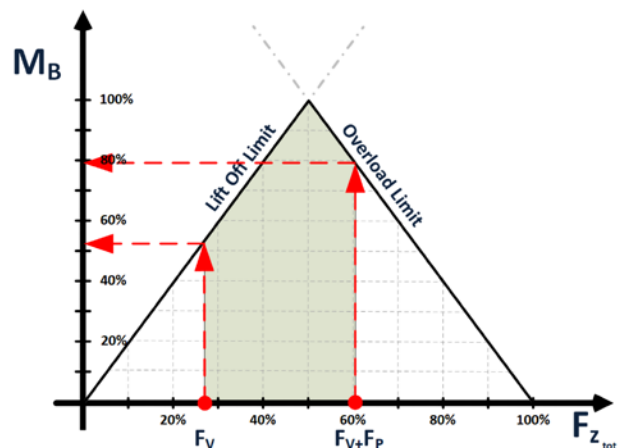

Fig. 5: maximum bending moment depending on preload and process force

$$M_B[28\%] = 100\% - 2 \times |50\% - 28\%| = 56\% \\ \hat{=} 122.6 \text{ Nm}$$

$$M_B[61\%] = 100\% - 2 \times |50\% - 61\%| = 78\% \\ \hat{=} 170.8 \text{ Nm}$$

The allowed bending moment depends on the applied total force F_z and reaches its peak at 50 kN, half the nominal axial force. In this case, when the process force is at 22 kN (28 kN+22 kN = 50 kN).

If the force curve in the process is not known, the lowest value is defined as the maximum load: 122.6 Nm.

Attention

Lateral loads $F_{x,y}$ and/or a torque M_z further reduce the measuring range. In case of tight safety margins regarding bending moments and suspected lateral loads or torque, better get in touch with our local sales.

Tensile forces

Tensile forces are only applicable as long as the preload is higher than the negative force: they reduce the (pre)load on the sensor, which can be measured accordingly.

9101C_003-473e-08.21

Measuring chain

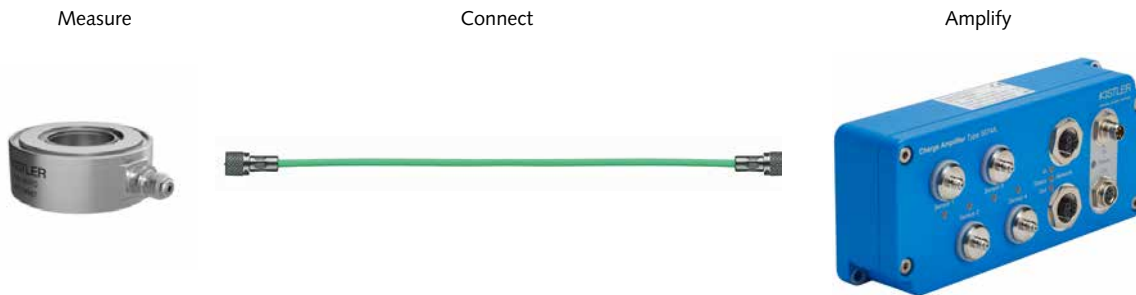

Fig. 6: Measuring chain

Connecting cable

All sensors of type 9101C ... 9107C have a KIAG 10-32 neg. connector and are compatible with all cable connectors KIAG 10-32 pos. Only highly insulating coaxial cables with low capacitance may be used to connect piezoelectric sensors. These cables generate very little frictional electricity when moving. Kistler uses cables made of high-quality PFA or oil-tight FPM. The IP protection class according to EN60529 on the sensor

side is basically dependent on the selected connector. For IP65 the standard cable connector 10-32 KIAG with knurled nut is used. For increased requirements in harsh environments the industrial version 10-32 KIAG pos. int. is applied, which can be welded tightly to the sensor housing if required and achieves IP68.

Compatibilities of cables and charge amplifiers

Cable	Cable Properties	Length [m]		Temp. Range	IEC/EN 60529	Connector Sensor	Connector Amplifier	IEC/EN 60529	Channel												
		min	max						Industrial Amplifier					Laboratory Amplifier				DAQ			
									5080A	5093A	5073A	5074A	5877B	5015A	5018A	5080A	5165A		5167A	KIDAQ	
1631C...	PFA	0.1	100	-55...200°C	IP65	KIAG 10-32 pos.	BNC pos.	IP40	1	1	1-4	1-4	1	1	1-8	1-4	4,8	IP20			
1641B...	PFA	0.1	100			KIAG 10-32 pos. 90°	BNC pos.		1	1	1-4	1-4	1	1	1-8	1-4	4,8	IP20			
1633C...	PFA	0.1	50			KIAG 10-32 pos.	TNC pos.		1	1	1-4	1-4	1	1	1-8	1-4	4,8	IP20			
1635C...	PFA	0.1	15			KIAG 10-32 pos.	KIAG 10-32 pos.		1	1	1-4	1-4	1	1	1-8	1-4	4,8	IP20			
1957A...	PFA, steel braiding	0.1	10			KIAG 10-32 pos.	KIAG 10-32 pos.		1	1	1-4	1-4	1	1	1-8	1-4	4,8	IP20			
1900A23A12..	PFA superflexible, drag chain proven	0.3	20			KIAG 10-32 pos. hex	BNC pos.		1	1	1-4	1-4	1	1	1-8	1-4	4,8	IP20			
1900A23A11..	PFA superflexible, drag chain proven	0.3	20			KIAG 10-32 pos. hex	KIAG 10-32 pos. hex		1	1	1-4	1-4	1	1	1-8	1-4	4,8	IP20			
1900A21A120x	FPM flexible steel hose	0.4	20			KIAG 10-32 pos. hex	BNC pos.		1	1	1-4	1-4	1	1	1-8	1-4	4,8	IP20			
1900A21A110x	FPM flexible steel hose	0.4	20			KIAG 10-32 pos. hex	KIAG 10-32 pos. hex		1	1	1-4	1-4	1	1	1-8	1-4	4,8	IP20			
1983AD...	FPM	0.1	5			-20...200°C	IP68		KIAG 10-32 pos. int.	BNC pos.	IP40	1	1	1-4	1-4	1	1	1-8	1-4	4,8	IP20
1939A...	PFA	0.1	20	-55...200°C	IP67	KIAG 10-32 pos. int.	BNC pos.	IP40	1	1	1-4	1-4	1	1	1-8	1-4	4,8	IP20			
1941A...	PFA	0.1	20			KIAG 10-32 pos. int.	TNC pos.		1	1	1-4	1-4	1	1	1-8	1-4	4,8	IP20			
1921...	PFA	0.1	20			KIAG 10-32 pos. int.	KIAG 10-32 pos.		1	1	1-4	1-4	1	1	1-8	1-4	4,8	IP20			
1969A...	PFA, steel braiding	0.5	10			KIAG 10-32 pos. int.	KIAG 10-32 pos. int. ²		1	1	1-4	1-4	1	1	1-8	1-4	4,8	IP20			
1967A...	PFA, steel braiding, isolated	0.5	10			KIAG 10-32 pos. int.	KIAG 10-32 pos. int. ²		1	1	1-4	1-4	1	1	1-8	1-4	4,8	IP20			
1979A...	FPM	0.1	20			KIAG 10-32 pos. int.	Fischer 103 Triax		1	1	1-4	1-4	1	1	1-8	1-4	4,8	IP20			
1983AC...	FPM	0.1	5			-20...200°C	IP68		KIAG 10-32 pos. int.	KIAG 10-32 pos. int. ²	IP40	1	1	1-4	1-4	1	1	1-8	1-4	4,8	IP20

¹ screwed: IP65

² welded: IP67

9101C_003-473e-08.21

Accessories (optional)

- Special grease
- Preloading screw for preloads for compression force measurement, including centering sleeve
- Preloading element screw for preloads for pressure and tensile force measurement including mounting accessories

Type

1063
9422A11
...
9422A51
9420A11
...
9420A71

Ordering key

Piezoelectric force sensor

Range 0 ... 20 kN	1
Range 0 ... 50 kN	2
Range 0 ... 100 kN	3
Range 0 ... 140 kN	4
Range 0 ... 190 kN	5
Range 0 ... 330 kN	6
Range 0 ... 700 kN	7

Type 910 C

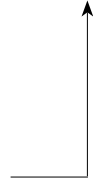

Mounting accessories

for PE force sensor 910xC (optional)

- Force distributing ring 95x5
- Spherical washer 95x3
- Insulating washer 95x7
- Force distributing cap 95x9

Cables (optional)

- Connection and extension cables (s. table on page 4)