

# ThermoCOMP cylinder pressure sensor

## Water-cooled pressure sensor for combustion engines

Type 6061C...

Water-cooled precision cylinder pressure sensor, especially suited for thermodynamic investigations in the early stages of the engine development process. High sensitivity, high natural frequency and excellent zero point stability thanks to built-in water cooling directly at the measuring element.

- Minimum sensitivity change over the temperature range due to integrated water cooling
- Thermo-shock and service life optimized diaphragm
- Installation in a  $\varnothing 14$  mm bore possible
- Installation compatible to pressure sensors Type 6061B
- Long service life

### Description

Use of robust measuring elements ensures that the sensor is also suitable for high mechanical loads. The higher-strength material of the diaphragm together with the cooling ensure a long service life. The water cooling ensures that the 6061C ... sensor is thermally stable over the entire power band of the engine (lower load-change drift), so that the sensor can be flush mounted even in installations with high operating temperatures.

### Application

The sensor Type 6061C... is well suited for thermodynamic measurements in combustion engines. The integrated water cooling ensures that the sensitivity remains almost constant over the temperature range. Thus, precise measurement results can be achieved in all operating points of the engine. Moreover, the excellent linearity in the whole range and the high sensitivity allow gas exchange to be analyzed accurately.

### Coolant regulation

- Demineralized / distilled water according to VDE standard 0510
- Coolant additive Glysantin G30 / G40 / G48 or equivalent products (do not mix them)
- Mixing ratio: 1 part coolant additive to 4 parts water (frost resistant up to  $-9$  °C)
- Details see instruction manual sensors / temperature control unit 2621G

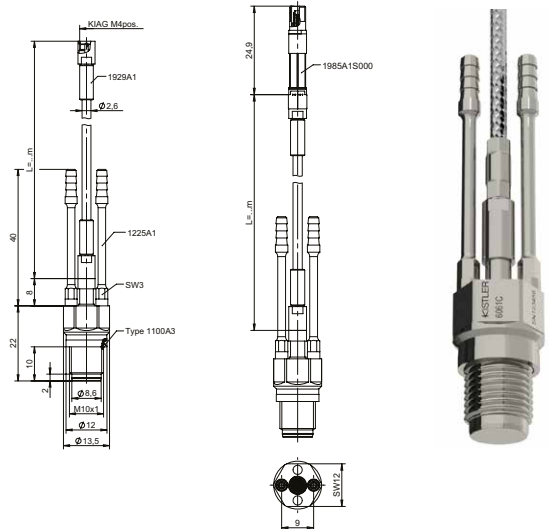

### Technical data

Measuring range	bar	0 ... 250
Calibrated ranges	bar	0 ... 50, 0 ... 100
RT, 50 °C		0 ... 150, 0 ... 250
Overload	bar	300
Sensitivity	pC/bar	$\approx -26$
Natural frequency	kHz	$\approx 90$
Linearity, all ranges (at RT / 50 °C)	%/FSO	$\pm 0.3$
Acceleration sensitivity		
axial (with cooling)	bar/g	$\leq 0.01$
radial (with cooling)	bar/g	$\leq 0.001$
Operating temperature range (uncooled)	°C	$-40 \dots 350$
Cooling-water flow	L/min	0.3 ... 0.5
Sensitivity shift		
RT ... 350 °C (uncooled)	%	$\pm 3$
50 °C $\pm 30$ °C (cooled)	%	$\pm 0.2$
Thermal shock error (at 1 500 1/min, IMEP = 9 bar)		
$\Delta p$ (short-term drift)	bar	$\pm 0.2$
$\Delta$ IMEP	%	$\pm 1$
$\Delta p_{max}$	%	$\pm 1$
Insulation resistance at RT	$\Omega$	$\geq 10^{13}$
Shock resistance	g	2 000
Tightening torque, greased	N·m	10
Capacity, without cable	pF	6
Weight of sensor, without cable	g	12
Connector, sapphire insulator		M4x0.35

**Mounting examples**

The sensor Type 6061C... can be flush mounted directly into the combustion chamber or - with recessed mounting - installed into a M10x1 bore. Tool 1300A5 enables installation up from a bore diameter of 14 mm (Fig. 1).

**Direct installation:**

When preparing the bore, it is imperative to observe the stated specifications exactly. The Kistler tap Type1353 allows you to meet the required tolerances. Flush mounting is to be preferred in order to avoid pipe oscillations (Fig. 1). A slightly recessed installation of up to 2 mm reduces the thermal load on the sensor. An alternative installation method uses a mounting position with a small diameter bore in front of the diaphragm. This offers excellent thermal shock protection but can be prone to pipe oscillations (Fig. 2).

**Installation with sleeve:**

Assuming that there is enough available space and / or fluid paths in the cylinder head need to be crossed in the installation, the use of an application-specific mounting sleeve is recommended. Fig. 3 shows the sensor Type 6061C ... mounted in the cylinder head, using a special mounting sleeve (option). An advantage of mounting sleeves is that the actual sensor bore in the sleeve can be manufactured with the required precision. On request, Kistler will gladly assist you with your specific installation situation, create drawings and manufacture the mounting sleeves.

**Maintenance**

Kistler recommends an annual calibration from the first use of the sensor. For further information refer to the instruction manual or contact your Kistler representative.

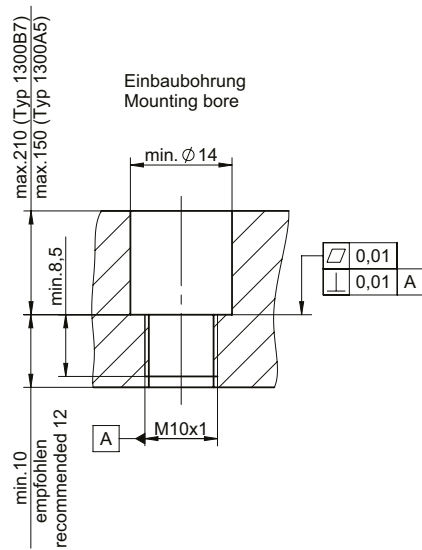

Fig. 1: Mounting bore for flush mounting

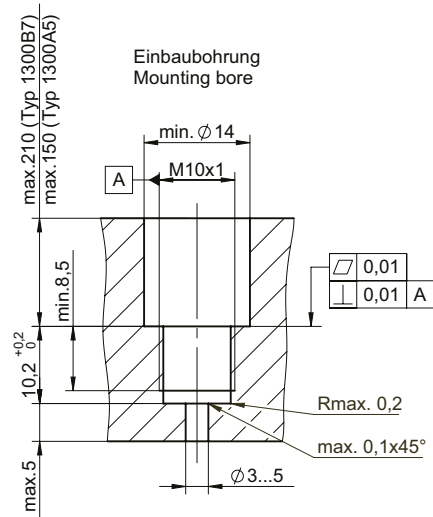

Fig. 2: Mounting bore with recessed mounting

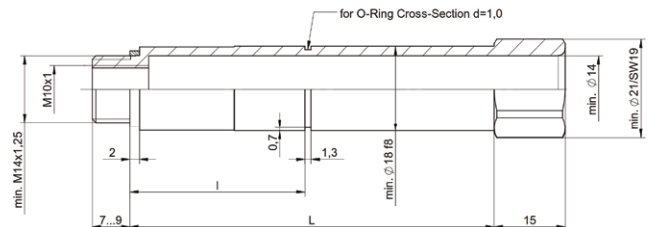

Fig. 3: Installation with mounting sleeve Type 6560AQ...

6061C\_003-454e-07.21

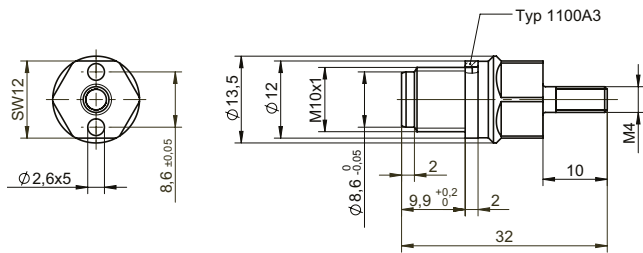

Fig. 4: Dummy sensor Type 6442

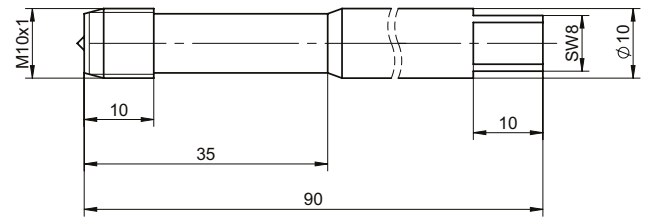

Fig. 8: Tap M10x1 Type 1353

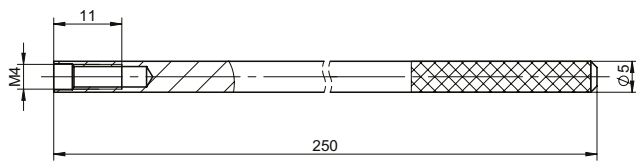

Fig. 5: Extraction tool Type 1319 for dummy sensor Type 6442

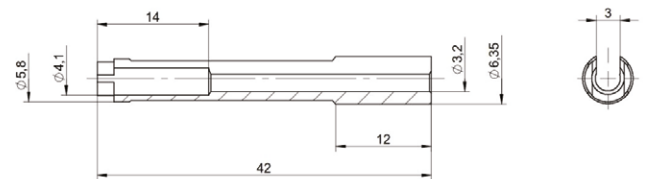

Fig. 9: Dismantling tool for cables Type 1300A49

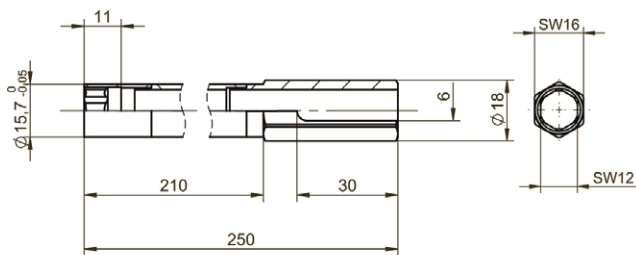

Fig. 6: Mounting wrench ø18/SW16 Type 1300B7 for mounting bore > ø16 mm

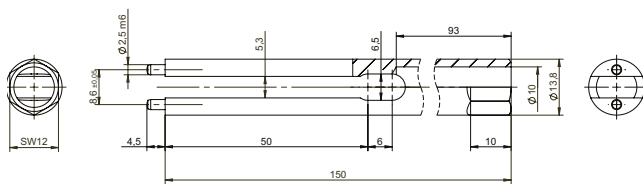

Fig. 7: Mounting wrench ø13,8/SW12 Type 1300A5 for mounting bore > ø14 mm

6061C\_003-454e-07.21

**Scope of delivery**

- Pressure sensor with pressed-on seal 1100A31
- Connecting cable acc. to ordering key
- Calibration certificate
- Coupling M4 neg. – BNC pos. (not for PiezoSmart)

**Optional accessories**

- PiezoSmart extension cables
  - l = 1 m 1987B1
  - l = 2 m 1987B2
  - l = 10 m 1987B10
- Spare connecting cables, PFA steel braided
  - l = 1 m 1929A1
  - l = 2 m 1929A2
  - l = 3 m 1929A3
  - with PiezoSmart, l = 1 m \* 1985A1S311
  - with PiezoSmart, l = 2 m \* 1985A1S321
  - with PiezoSmart, l = 3 m \* 1985A1S331
- Spare connecting cables, FPM oil-proof
  - l = 1 m 1983AA1
  - l = 2 m 1983AA2
  - l = 3 m 1983AA3
  - with PiezoSmart, l = 1 m \* 1985A1S711
  - with PiezoSmart, l = 2 m \* 1985A1S721
  - with PiezoSmart, l = 3 m \* 1985A1S731
- Dismantling tool for cables 1300A49
- Cr-Ni seal ring (replacement for pressed-on sensor seal) 1100A3
- Connecting tubes for cooling water, l = 40 mm 1225A1
- FPM tube for cooling water 1203CSP
- Temperature control unit 2621G
- Dummy sensor 6442
- Extract. tool for dummy sensor Type 6477 1319
- Mounting sleeve M14x1,25 (custom made) 6560AQ...
- Adapter for pressure generator Type 6904 6583
- Adapter for pressure generator Type 6905A 6925
- Tap M10x1 1353
- Mounting wrench SW12/D13,8 (l = 140) 1300A5
- Mounting wrench SW16/D18 (l = 210) 1300B7
- Torque wrench (4 ... 20 N·m) 1300A39
- Fork wrench insert SW12 for Type 1300A5 1300A13
- Fork wrench insert SW16 for Type 1300B7 1300A33
- Protective cap for sensor plug M4x0.35 1895

\* With factory calibration data, state SN with order

**Type/Art. No.**  
6061C

**Ordering key**

**PiezoSmart**

Without PiezoSmart (standard)	–
With PiezoSmart (standard)	s

**Cable version**

PFA steel braided (standard)	3
------------------------------	---

**Cable length**

1 m (standard)	–1
----------------	----

Type 6061C

**Ordering example:**

Standard sensor without PiezoSmart and 1 m PFA cable:  
Type 6061C-3-1

6061C\_003-454e-07.21