

## MicroDyn

Type 9109AA

### Multicomponent dynamometer up to 500 N, cover plate 30x30 mm

Multicomponent dynamometer for measuring the three orthogonal components of a force and the torque  $M_z$ . The very low threshold and the high sensitivity allow even the smallest forces to be measured. With a natural frequency higher than 15 kHz in all three axes, highly dynamic forces can be recorded with extremely high accuracy.

- Very compact design
- Patented sensor arrangement
- High sensitivity and natural frequency
- Reduced influence of temperature through compensation
- Cover plate made of hard-anodized lightweight material
- For cutting force measurements in micro-machining
- For general multicomponent force measurements

#### Description

The dynamometer consists of four, 3-component force sensors which are mounted under high pretension between the cover plate and the four lateral assembly elements. Thanks to this special mounting of the sensors, temperature influences can be partially compensated for and the influence of the temperature thereby minimized. The force measurement of the sensors is based on the piezoelectric principle. The application of a force causes the crystal rings installed in the sensor (one crystal ring for each of the force components that is to be measured) to release a charge that is proportional to this force. The charge signals of the four installed force sensors are internally connected and output by a 9-pin flange socket. In addition to the direct measurement of the three force components, an indirect measurement of the torque  $M_z$  is possible through an appropriate calculation. The sensors are mounted ground-isolated (dry state). Ground-loop problems can thereby be largely avoided.

The dynamometer is corrosion resistant and protected against the penetration of cooling lubricant. Together with the 8-pin connecting cable Type 1677A5, Type 1677AQ02 or Type 1679A5, the dynamometer is protected against the penetration of dust and liquids according to degree of protection IP67.

#### Application examples

- Multicomponent force measurement of extremely small and highly dynamic forces
- Cutting force measurement in
  - precision machining
  - micromachining
  - ultra-high precision machining of brittle materials



#### Technical data

Measuring range (central), Single component	$F_x, F_y, F_z$ $M_z$	N N·m	-500 ... 500 -50 ... 50
Measuring range when components act simultaneously (central)	$F_x, F_y, F_z$ $M_z$	N N·m	-250 ... 250 25
Calibrated measuring range			
100%	$F_x, F_y, F_z$	N	0 ... 500
10%	$F_x, F_y, F_z$	N	0 ... 50
2%	$F_x, F_y, F_z$	N	0 ... 10
Overload (central)	$F_x, F_y, F_z$ $M_x, M_y$ $M_z$	N N·m N·m	-1 000/1 000 -30/30 -60/60
Threshold		N	<0.002
Average sensitivity	$F_x, F_y$ $F_z$	pC/N pC/N	≈-12.5 ≈-20
Linearity			
Measuring range 10% ... 100%		%/FSO	≤±0.5
Measuring range 0% ... <10%		%/FSO	≤±1.0
Hysteresis			
Measuring range 10% ... 100%		%/FSO	≤±0.5
Measuring range 0% ... <10%		%/FSO	≤±1.0
Crosstalk	$F_x \rightarrow F_y$ $F_x \rightarrow F_z$ $F_y \rightarrow F_x$ $F_y \rightarrow F_z$ $F_z \rightarrow F_x$ $F_z \rightarrow F_y$	% % % % % %	≤±4 ≤±2 ≤±4 ≤±2 ≤±2 ≤±2
Natural frequency (without additional mass)	$f_n(x)$ $f_n(y)$ $f_n(z)$	kHz kHz kHz	>15 >15 >15
Operating temperature range		°C	-20 ... 70
Capacitance	$X_1, X_3, Y_2, Y_4$ $X_{2+4}, Y_{1+3}$ Z	pF pF pF	≈60 ≈120 ≈240
Insulation resistance (20 °C)		Ω	>10 <sup>13</sup>
Ground isolation (dry state)		Ω	>10 <sup>8</sup>
Degree of protection EN60529		-	IP67 <sup>1)</sup>
Weight	Dynamometer Cover plate	kg kg	1.040 0.050
Mounting surface		mm	30x30

<sup>1)</sup> With connecting cable Types 1677A5, 1677AQ02, 1679A5

Page 1/4

The information corresponds to the current state of knowledge. Kistler reserves the right to make technical changes without advance notice. Liability for consequential damages arising from the application of Kistler products is excluded.

© 2018 Kistler Group, Eulachstrasse 22, 8408 Winterthur, Switzerland  
Tel. +41 52 224 11 11, info@kistler.com, www.kistler.com  
Kistler Group products are protected by various intellectual property rights. For more details visit: www.kistler.com

**Dimensions**

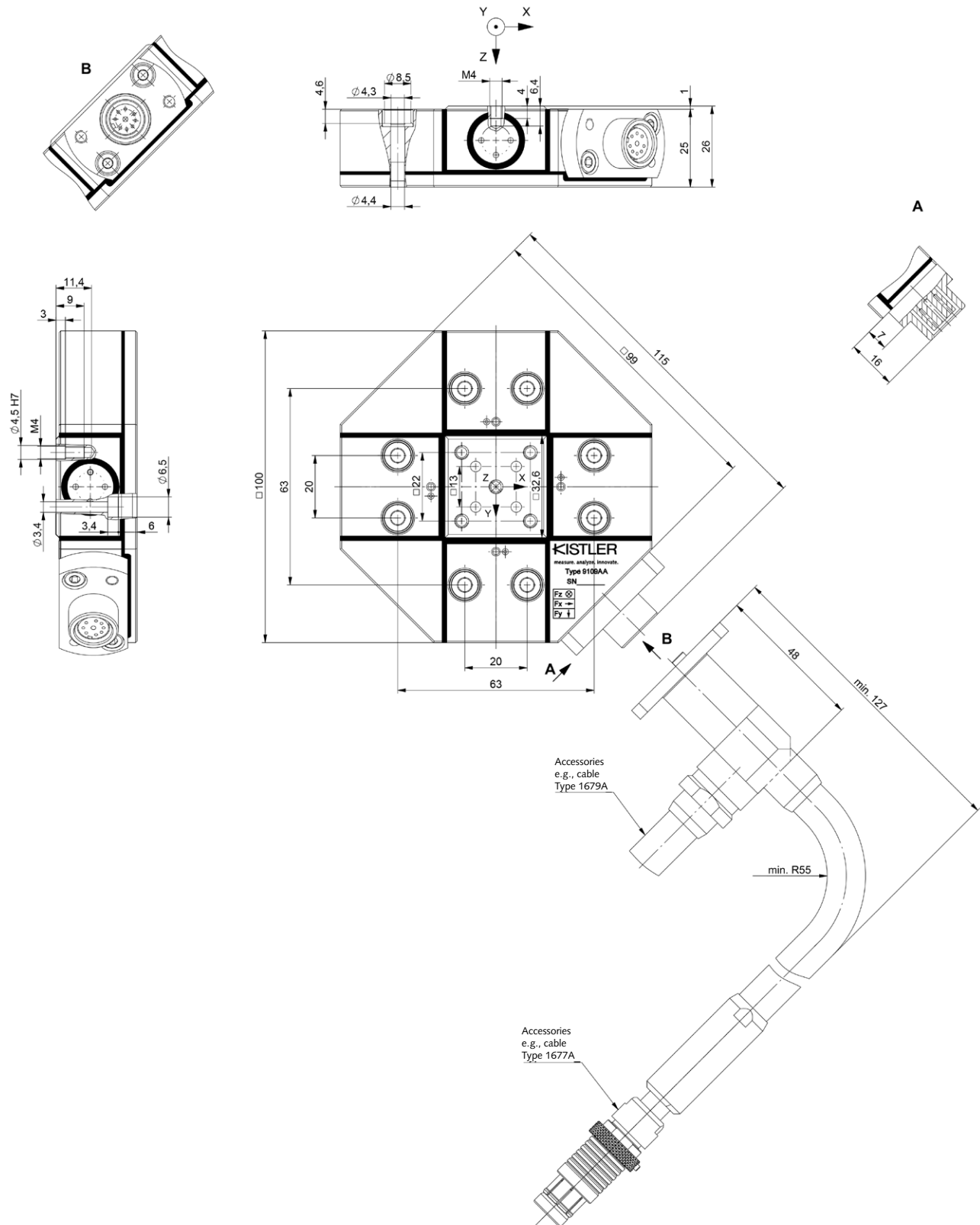

Fig. 1: Dimension of dynamometer Type 9109AA

**Mounting**

The dynamometer can be mounted with eight M4 screws to any face-ground, clean mounting surface, such as on a machine tool table. Mounting on a magnetic plate is made possible by means of a supplied steel base plate. It must be noted that uneven contact surfaces may cause internal distortions, which could place additional heavy stresses on the individual links and increase crosstalk.

M4 tapped blind holes, Ø3.4 through holes as well as 4.5H7 fittings are provided in the cover plate for mounting the force-introducing components such as workpieces or work holders. The contact surfaces of the force-introducing parts must be surface ground to achieve good mechanical coupling to the cover plate.

**Measuring signal processing**

The sensor outputs the charges of the individual sensors via a 9-pin connector with the following pin assignment.

Pin no.	Output signals Type 1677A/1679A
1	Ground
2	F <sub>x'1</sub>
3	F <sub>x'2+4</sub>
4	F <sub>x'3</sub>
5	F <sub>y'1+3</sub>
6	F <sub>y'2</sub>
7	F <sub>y'4</sub>
8	F <sub>z'1+2+3+4</sub>
9	NC

To convert the charges output by the sensor to a voltage that can be used by data acquisition devices, multi-channel charge amplifiers are used (e.g., Type 5080A or Type 5167A81). The measurement value of the individual channels is proportional to the applied force.

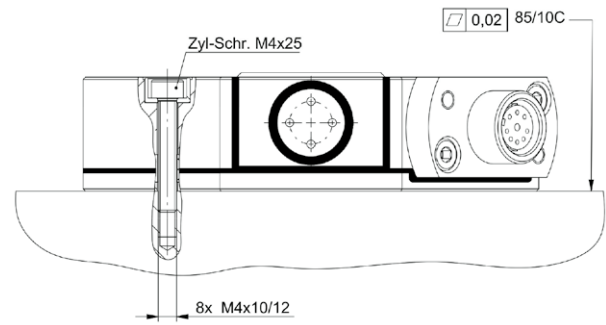
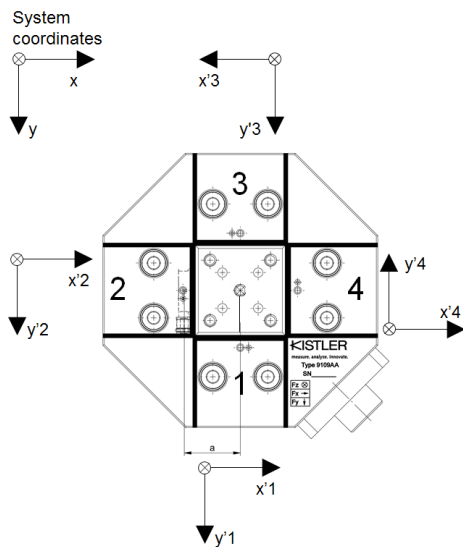

Fig. 2: Mounting the dynamometer Type 9109AA  
Mounting on machine table

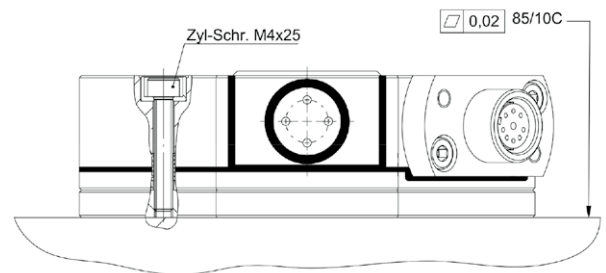

Fig. 3: Mounting the dynamometer Type 9109AA  
Mounting with steel base plate on magnetic table

**Data acquisition**

If a high-end laboratory charge amplifier Type 5080A is used, Kistler offers a universal and simple to operate package with DAQ system Type 5697A1 consisting of hardware for data acquisition as well as the DynoWare software. For details, see data sheet doc. no. 5697A\_000-745.

If charge amplifier Type 5167A81 is used, this is available as model Type 5167A81DK with digitalization and the Dynoware software in the package. This eliminates the need for other external data acquisition, thereby reducing wiring work considerably.

**Data analysis**

To calculate the three orthogonal force components and the torque M<sub>z</sub> from the output signals, the following equations are used:

	System coordinates	Outputs
F <sub>x</sub>	= F <sub>x1</sub> + F <sub>x2+4</sub> + F <sub>x3</sub>	= F <sub>x'1</sub> + F <sub>x'2+4</sub> - F <sub>x'3</sub>
F <sub>y</sub>	= F <sub>y2</sub> + F <sub>y1+3</sub> + F <sub>y4</sub>	= F <sub>y'2</sub> + F <sub>y'1+3</sub> - F <sub>y'4</sub>
F <sub>z</sub>	= F <sub>z1+2+3+4</sub>	= F <sub>z'1+2+3+4</sub>
M <sub>z</sub>	= (-F <sub>x1</sub> - F <sub>y2</sub> + F <sub>x3</sub> + F <sub>y4</sub> ) · a · k <sub>Mz</sub>	= (-F <sub>x'1</sub> - F <sub>y'2</sub> - F <sub>x'3</sub> - F <sub>y'4</sub> ) · a · k <sub>Mz</sub>

When using the Dynoware software, these calculations rules are stored in a template, eliminating the need for additional programming when setting up the system and thereby avoiding errors.

9109AA\_003-346e-08:18

**Measuring system for 4-component measurement  $F_x, F_y, F_z, M_z$**

Dynamometer  
Type 9109AA

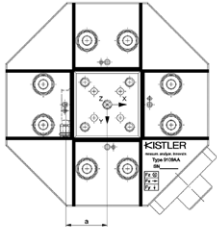

Connecting cable  
Type 1677A5  
Type 1677AQ02  
Type 1679A5





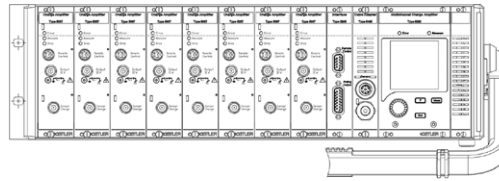

Multichannel charge amplifier  
Type 5080Axx8x004



Output $\pm 10$ V	
Ch1	$F_{x1}$
Ch2	$F_{x2+4}$
Ch3	$F_{x3}$
Ch4	$F_{y1+3}$
Ch5	$F_{y2}$
Ch6	$F_{y4}$
Ch7	$F_{z1+2+3+4}$
Ch8	NC

Fig. 4: Measuring system for 4-component measurement  $F_x, F_y, F_z, M_z$

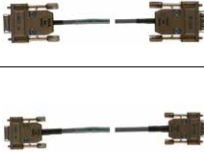
**Typical Measuring Chain with DAQ System Type 5697A1**

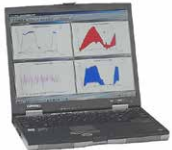
					
Dynamometer	High resistant cable	Charge amplifier	Connecting cable	DAQ system	Notebook (customer) with DynoWare
Type 9109A	Type 1677A5	Type 5080A	Type 1700A111A2 Type 1200A27	Type 5697A1	

**Ordering code**

- Multicomponent dynamometer up to 500 N, cover plate 30x30 mm

**Type/part. no.**

**9109AA**

**Included accessories:**

- Mounting screws M4x25 (8 pieces) **65012704**
- Steel base plate for magnetic mounting **55174784**

**Optional accessories**

- Connecting cable, 8-wire with metal shield sheath **1677A5**
- Connecting cable, 8-wire with flexible sheath **1677AQ02**
- Connecting cable, 8-wire with metal shield sheath and angle connector **1679A5**

9109AA\_003-346e-08:18