

# Cavity Pressure Sensor

## with Front $\varnothing 2$ mm

Type 6185A...

Miniaturized piezoelectric sensor with single-wire technology for mold cavity pressures up to 2 000 bar in the injection molding of plastics.

- Ideally suited for industrial applications
- Designed without a diaphragm and with a level, machinable front face
- Also available with chromed face for abrasive plastics
- Exchangeable cable
- With venting slot for degassing plastics
- Also as cable free version with conductive spacer sleeve
- Insensitive to the mounting bore

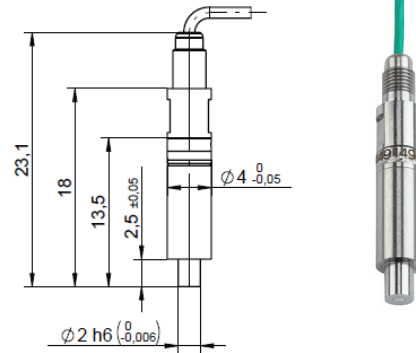

### Description

The miniaturized sensor for mold cavity pressure Type 6185A... has a 2 mm diameter front face. The very small crosssectional area of the single-wire cable allows flexibility of installation. Shielding in the single-wire technology is provided by the mold. It is therefore essential for the cable and connector to be integrated in the mold.

In the uncoated versions, the front face can be machined up to 0,5 mm in order to adapt it to the contour of the mold cavity. For these Types, it is thus possible to mount a keyway-pin which prevents the sensor rotating in the mounting bore.

For multi cavity applications the sensor Type 6185A...G is used without the single-wire connector Type 1839.

The pressure acts over the entire front of the sensor and is transmitted to the measuring element, which produces a proportional electric charge (pC = Picocolomb). This is converted into a voltage 0 ... 10 V in the amplifier and is then available as an amplifier output.

### Application

It is mainly suitable for industrial applications for monitoring and open-looped and closed-looped control in thermoplastic injection molding.

### Technical Data

Range	bar	0 ... 2 000
Overload	bar	2 500
Sensitivity	pC/bar	-2,2
Linearity, all ranges	% FSO	$\leq \pm 1$
Operating temperature range		
Mold (Sensor, cable, connector)	°C	0 ... 200*
Melt (on sensor front face)	°C	<450
Insulation resistance		
at 20 °C	TΩ	>10
at 200 °C	TΩ	>1

\* During machine down-time, the mold temperature may be allowed to rise to 240 °C without damaging the sensor. However, measuring errors may occur

**Cable and Amplifier for Measuring Chain with Sensor Type 6185A...**

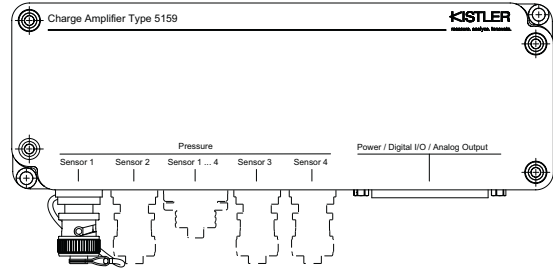
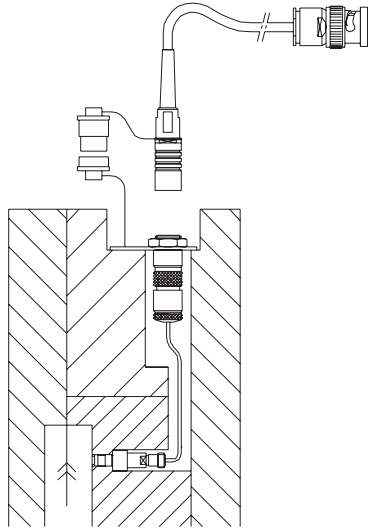

<b>Cable Type 1667B... (BNC connector)</b>
Type 5159A

Fig. 1: Sensor Type 6185A... with Charge Amplifier Type 5159A.

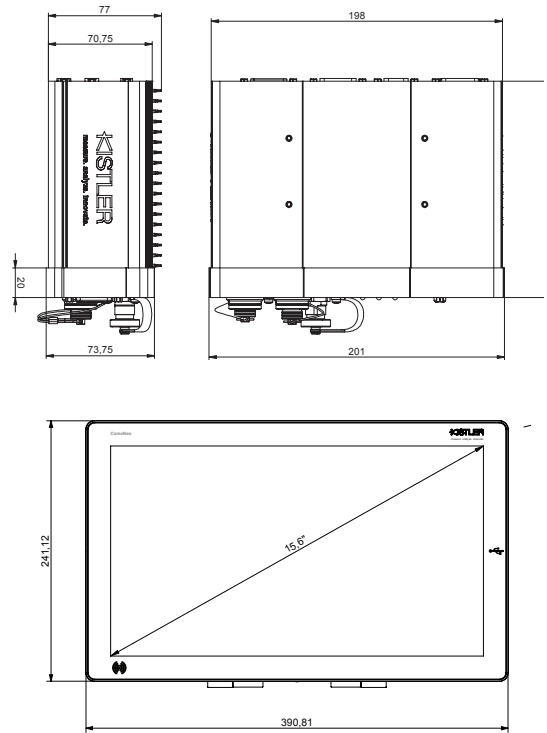
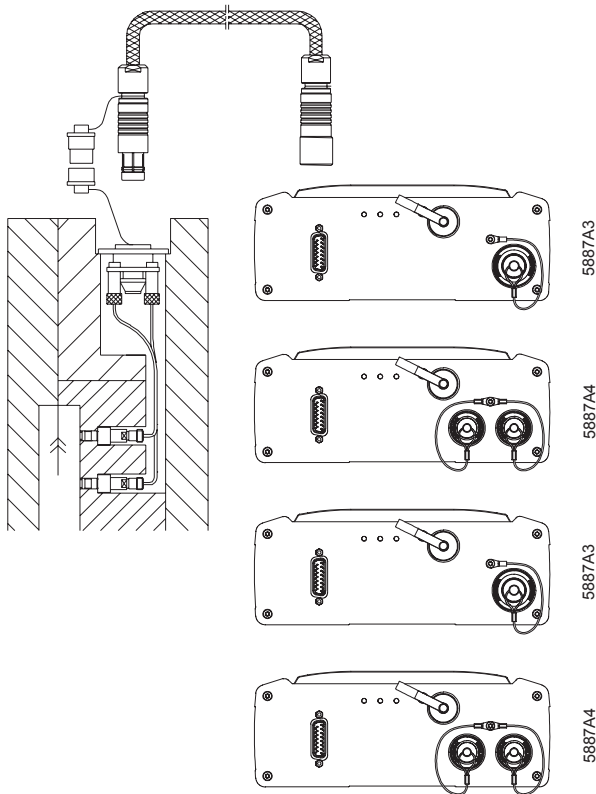

<b>4-channel cable Type 1995A... to connector Type 1722A4...</b>	<b>8-channel cable Type 1997A... on connector Type 1722A8...</b>
Type 5887A1	Type 5887A2...
	Type 5887A3...
	Type 5887A4...

Fig. 2: Sensor Type 6185A... with Monitoring System ComoNeo Type 5887...

Installation Examples

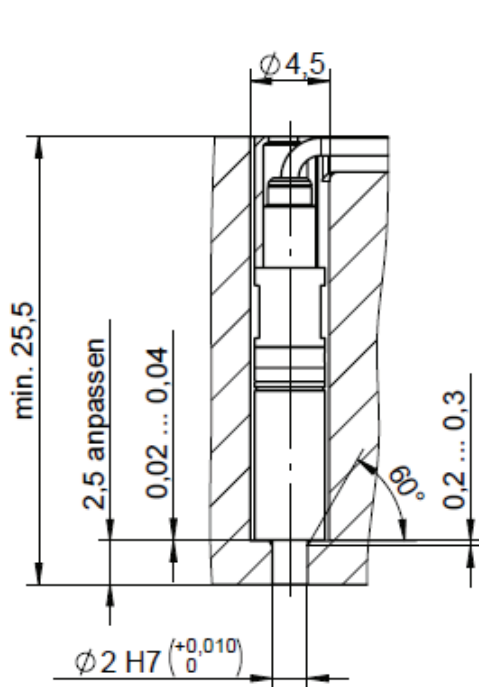

Fig. 3: Installation with spacer sleeve Type 6464A1

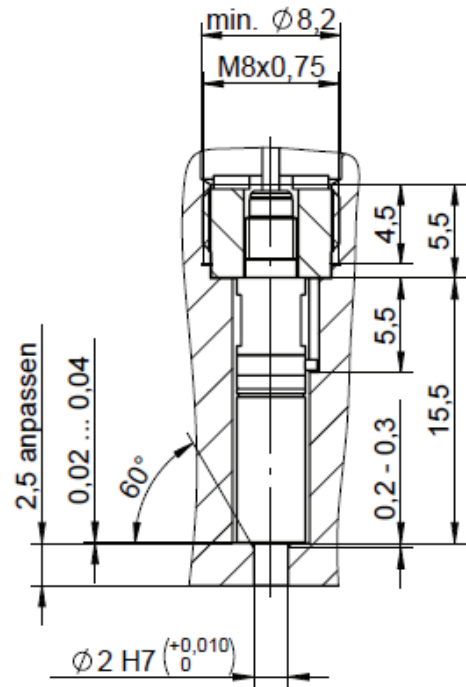

Fig. 4: Optional installation with mounting nut Type 6460A1 and key way pin Type 65001430

Installation Examples

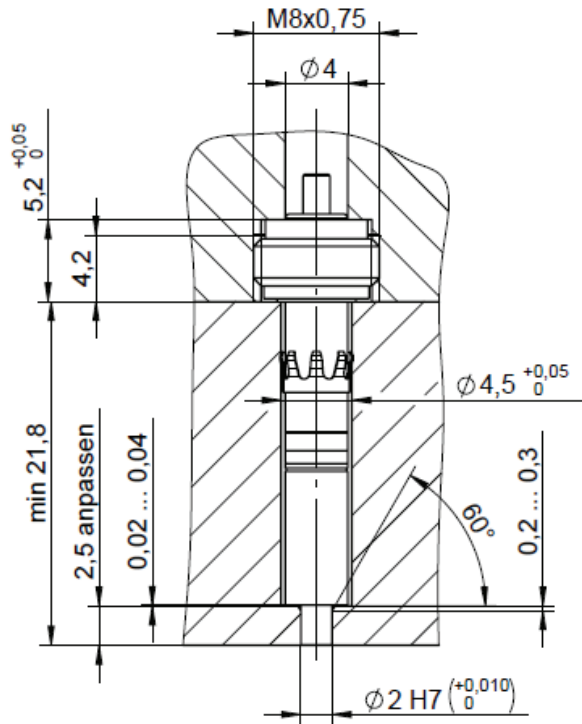

Fig. 5: Installation of the Types 6185A...N... with conducting spacer sleeve

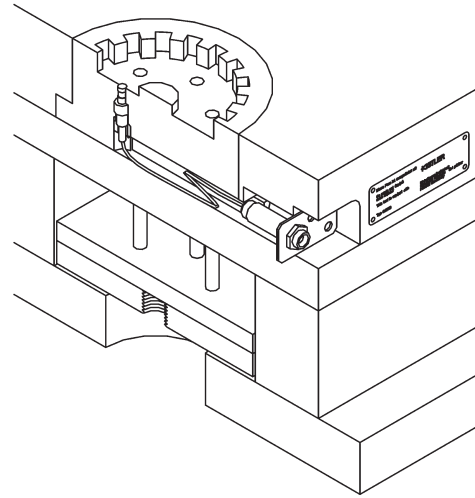

Fig. 6: Sensor, cable, mounting plate and identification plate

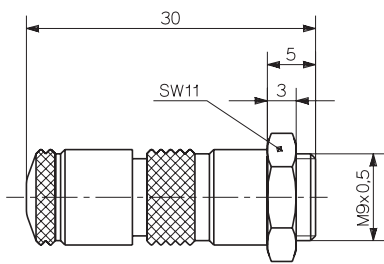

Fig. 7: Connector Type 1839

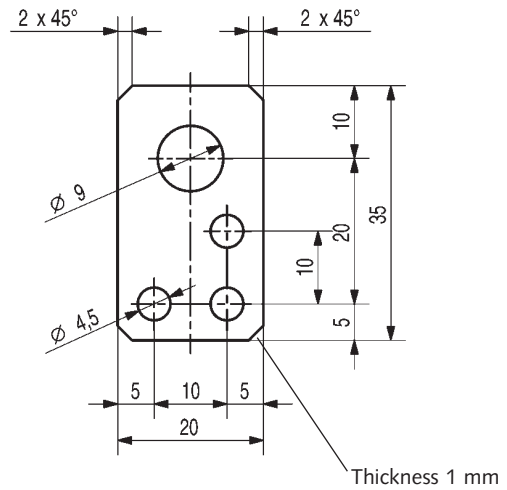

Fig. 8: Mounting plate (Mat. No. 65005208)

6185A\_003-263e-10.16

## Installation

The sensor is preferably fitted in the mounting bore with the spacer sleeve (Type 6464A1). In case of installation with a keyway pin, however, the mounting nut Type 6460A1 should be used.

The front face of the sensor forms part of the cavity wall. The sensor must therefore be installed in such a way that its front face is exactly flush with the wall.

The single-wire cable must be installed completely in the mold. The connector supplied must be installed with the single-wire cable cut to length. The insulation of the cable must not be stripped prior to insertion into the connector. This connector is fitted in the mounting plate and this secured in a recess in the mold. The identification plate should be fixed nearby, indicating the type of sensor and its sensitivity.

## Ordering Key

### Sensor

Sensor front uncoated, keyway pin	<b>A</b>
Sensor front chromed	<b>C</b>

### Cabel

Sensor with single-wire-cable (L = 1,5 m)	<b>E</b>
Sensor with single-wire-cable (L = 5 m)	<b>E1</b>
Sensor with single-wire-cable, without connector (L = 1,5 m)	<b>G</b>
Sensor with single-wire-cable, without connector (L = 5 m)	<b>G1</b>

### For contact elements Types 1712B... and 1714B...

Sensor with single-wire-cable and crimped pin (Mat. Nr. 65003747). Cable with special lengths. Specify L in m. (L <sub>min</sub> = 0,04 m/L <sub>max</sub> = 1,5 m)	<b>Zsp</b>
Sensor with conducting spacer sleeve Type 1720A1 and contact element Type 1712B1	<b>NE</b>
Sensor with conducting spacer sleeve Type 1720A1 and contact element Type 1712B1, without connector	<b>NG</b>

Type 6185A□□



## Accessories Included

	Mat. No./Type
• Spacer sleeve (L = 50 mm)	6464A1
• Conducting spacer sleeve (L = 40 mm)	1720A1
• Mounting plate	65005208
• Connector (with cap)	1839
• Checking tool	55155779
• Identification plate	55147987

## Optional Accessories

	Mat. No./Type
• Replacement cable single wire 1,5 m	1900A17L1,5
• Replacement cable single wire 5 m	1900A17L5
• Auxiliary tool to dismount the cable	1300A30
• Dummy sensor	6478A1
• Extraction tool	1358A
• Mounting nut	6460A1
• Installation tool for mounting nut	1300A131
• Keyway pin	65001430
• 4-channel connector for Type 6185A...G and 6185A...G1	1722A4...
• 8-channel connector for Type 6185A...G and 6185A...G1	1722A8...
• Contact elements 1 channel for Type 6185A...Zsp	1712B0
• Contact elements 4 channels for Type 6185A...Zsp	1714B0
• Crimped pin	65003747
• Crimpset with tools	1381A0