

Lower Tibia Load Cell

Type M55395A...

Five-axial

Type M55395A... is designed to measure forces and moments in the lower tibia of the crash test dummies Thor-M (TH) and Thor-LX.

- Five-axial (F_x , F_y , F_z , M_x , M_y)
- UPS module available
- Low linearity errors and hysteresis errors
- Kistler system cabling
- Polarities according to SAE J211/1

Description

The load cell is made of elements on which forces and moments are transmitted. The mechanical deformation element, applied with strain gage, serves for mechanical electrical deformation. The forces and moments to be measured create mechanical stretches and buckling in the gaging member. In order to avoid linearity errors, the deformation paths are constructively held small (high rigidity).



Thus a proportional behavior is realized. The force and moment proportional resistance variations are measured by a Wheatstone-type bridge circuit. The load cell is available with UPS module which is integrated in an external housing in the wiring or in the connector. Customized cable lengths and connectors with specific pin assignments are optionally available.

Technical Data

Axial Data		F_x	F_y	F_z	M_x	M_y
Measuring range	kN	11	11	11		
	N·m				400	400
Bridge output voltage (typ.)	mV/V	2,0	2,0	1,0	2,8	2,8
Sensitivity (typ.)	$\mu\text{V}/\text{V}/\text{kN}$	180	180	90		
	$\mu\text{V}/\text{V}/\text{N}\cdot\text{m}$				7,0	7,0
Bridge resistance	Ω	700	700	700	350	350
Ultimate load, static	%	150	150	150	150	150

General Data

Supply voltage ¹⁾	VDC	2,5 ... 15
Insulation resistance ²⁾	G Ω	>10
Operating temperature range	$^{\circ}\text{C}$	-20 ... 80
Storage temperature range	$^{\circ}\text{C}$	-30 ... 90
Amplitude non-linearity (typ.)	%	<1
Hysteresis (typ.)	%	<1
Channel cross talk	%	<5
Bridge zero output (typ. / max.)	mV/V	0,01 / 0,03
Weight, without cable	grams	524

All specifications are typical at 25 $^{\circ}\text{C}$ and rated at 10 V sensor supply voltage, unless otherwise specified.

¹⁾ With UPS module 9 ... 12 VDC

²⁾ All wires to load cell housing, measured with 500 VDC

Application

The load cell is directly assembled at the designated location in the dummy and provides important information about the loads on the human body occurring during a crash test.

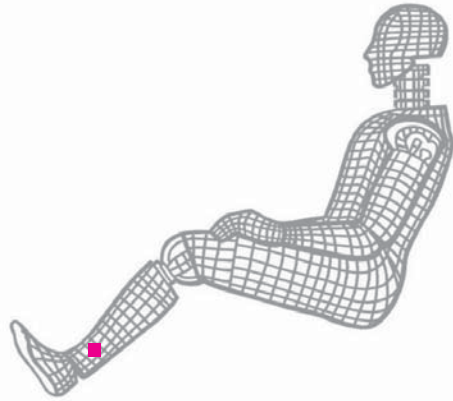

Fig. 1: Dummy application Lower Tibia

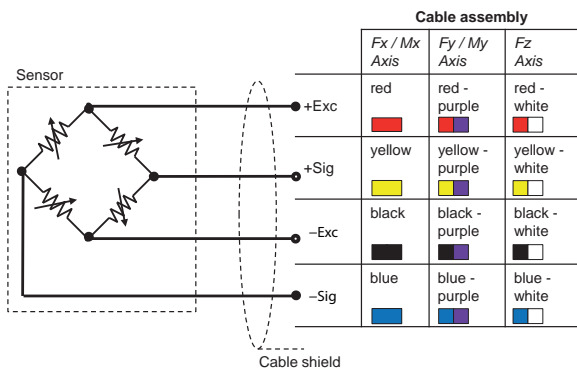

Fig. 2: Cable assembly

Included Accessories

- Mounting screws with MIL-LX/MX design version

Type No.

on request

Optional Accessories

- Add. label, customized
- UPS module
- Add. shunt

Type No.

M015KABID
on request
on request

Ordering Key

Type M55395A

Design

Standard	RM
With MIL-LX/MX screw set	8M

Cable Length before Electronics

0 cm	00
<10 cm (digit x 1 cm)	C#
10 cm ... 9,9 m (digit x 10 cm)	##
10 m ... 90 m (digit x 10 m)	D#

Additional Electronics

Sensor detail, as per type declaration force-moment TP-650-2	#
--	---

Cable Length after Electronics

0 cm	00
<10 cm (digit x 1 cm)	C#
10 cm ... 9,9 m (digit x 10 cm)	##
10 m ... 90 m (digit x 10 m)	D#

Connector

Conn. type, as per TP-600	#-
Conn. assignment, as per TP-600	-#

M55395A_003-209e-10.15

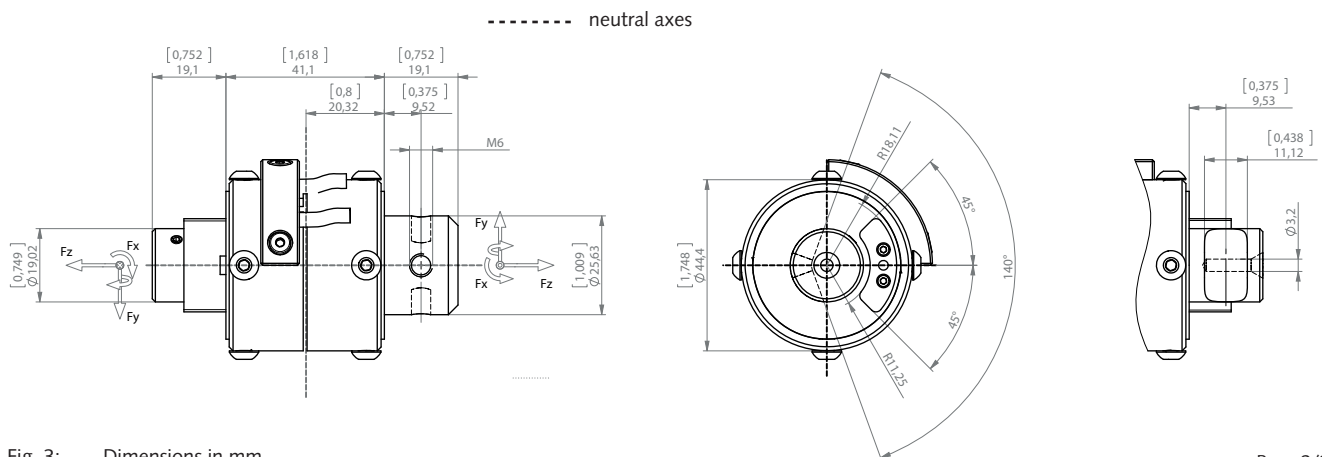

Fig. 3: Dimensions in mm

This information corresponds to the current state of knowledge. Kistler reserves the right to make technical changes. Liability for consequential damage resulting from the use of Kistler products is excluded.

©2015, Kistler Group, Eulachstrasse 22, 8408 Winterthur, Switzerland
Tel. +41 52 224 11 11, Fax +41 52 224 14 14, info@kistler.com, www.kistler.com
Kistler is a registered trademark of Kistler Holding AG.