

# Ceramic Shear Triaxial Accelerometer

Type 8764B...

## Miniature IEPE Through Hole Triaxial Accelerometer

Type 8764B... is a miniature, 6 gram center hole triaxial accelerometer with a  $\pm 50g$ ,  $\pm 100g$ ,  $\pm 250g$ ,  $\pm 500g$ ,  $\pm 1000g$ , and  $\pm 2000g$  measurement ranges. It measures vibration in three orthogonal axes with 360° cable orientation possibilities.

- Low mass
- Easy connector orientation
- M4.5 and ¼–28, 4 pin connector options
- Hermetic, titanium construction
- Low base strain sensitivity
- Voltage output
- Ceramic shear sensing element
- Ground isolated
- TEDS option
- Conforming to C€

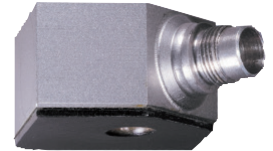

### Description

Type 8764B... is an IEPE (Integrated Electronics Piezoelectric) triaxial accelerometer permitting vibration measurements in three mutually perpendicular axes: x, y and z.

Type 8764B... uses Kistler shear element technology, assuring high immunity to base strain. The accelerometer uses a welded titanium construction for low mass and hermeticity and an industry standard 4 pin connector, as well as a miniature 4 pin connector for lower mass. The aluminum anodized base provides ground isolation from mounting surfaces. Type 8764B... has a center hole mounting permitting flexibility for 360° orientation of the cable and allowing a wide selection of locations for mounting.

### Application

Type 8764B... provides wide frequency response in each axis, ideal for dynamic vibration measurement. Its low profile allows usage when space is limited. It is well-suited for many applications, such as automotive NVH and durability testing, Space and Aerospace vehicle testing, and vibration testing of sub-systems.

### Accessing TEDS data

Accelerometers with a "T" suffix are variants of the standard version incorporating the "Smart Sensor" design. Viewing an accelerometer's data sheet requires an Interface/Coupler, such as Kistler LabAmp Type 5165A... The interface operates per the Class 1 MMI defined in IEEE 1541.4, altering the operating mode of the PiezoSmart® sensor while allowing the program editor software to read or add information contained in the memory chip.

### Dimensions

Type	8764BxAx	8764BxBx
A	M4.5	¼–28
B	21.6 [0.85]	24.74 [0.97]

Dimensions are shown in mm [in]

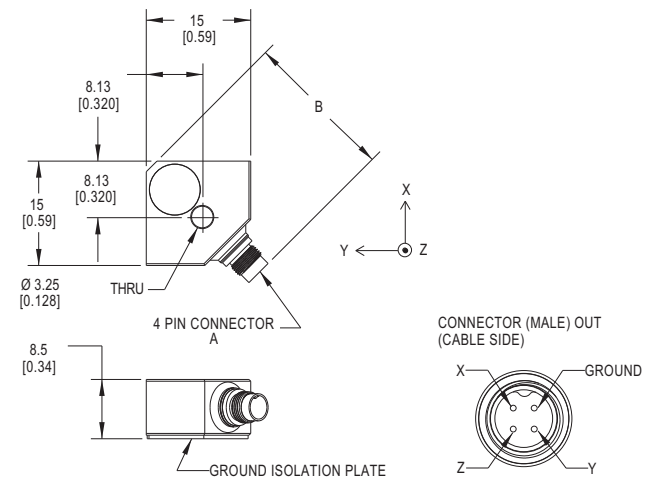

Outline drawing for type 8764Bxxxxx (units: mm [in])

8764B\_003-201e-11.20

## Technical data

Type number	Unit	8764B050...	8764B100...	8764B250XX	8764B500XX	8764B1K0XX	8764B2K0XX
Acceleration range	g	±50	±100	±250	±500	±1,000	±2,000
Acceleration limit	g	±100	±200	±500	±1,000	±2,000	±2,000
Threshold (1 ... 10,000 Hz)	$g_{rms}$	<0.0004	<0.0006	< 0.0015	< 0.0025	< 0.0035	< 0.0045
Sensitivity @100 Hz (±15%)	mV/g	100	50	20	10	5	2.5
Resonant frequency, mounted (nom.)	kHz	50	50	>55	>55	>55	>55
Frequency response, (±5%) (±10%)	Hz	0.5 ... 10,000 0.3 ... 15,000	0.5 ... 10,000 0.3 ... 15,000	1...10,000 1...15,000	1...10,000 1...15,000	1...10,000 1...15,000	1...10,000 1...15,000
Amplitude linearity	%FSO	±1	±1	±1	±1	±1	±1
Time constant, nom.	s	≥0.8	≥0.8	≥ 0.4	≥ 0.4	≥ 0.4	≥ 0.4
Transverse sensitivity (max. 5%), typ.	%	2.5	2.5	2.5	2.5	2.5	2.5

## Environmental

Base strain sensitivity @250 $\mu\epsilon$	g/ $\mu\epsilon$	0.0015	0.0015	0.0072	0.0072	0.0072	0.0072
Shock limit (1 ms pulse), max.	$g_{pk}$	5,000	5,000	5,000	5,000	5,000	5,000
Temp. coeff. of sensitivity, -55 ... 23°C -65 ... 75°F	%/°C %/°F	0.07 0.04	0.07 0.04	0.08 0.05	0.08 0.05	0.08 0.05	0.08 0.05
Temp. coeff. of sensitivity, 23 ... 100°C 75 ... 210°F	%/°C %/°F	-0.01 -0.006	-0.01 -0.006	-0.01 -0.006	-0.01 -0.006	-0.01 -0.006	-0.01 -0.006
Operating temperature range	°C °F	-54 ... 100 -65 ... 212	-54 ... 100 -65 ... 212	-54 ... 100 -65 ... 212	-54 ... 100 -65 ... 212	-54 ... 100 -65 ... 212	-54 ... 100 -65 ... 212

## Output

Bias, nom.	VDC	13	13	13	13	13	13
Impedance	$\Omega$	<100	<100	<100	<100	<100	<100
Voltage, full-scale	V	±5	±5	±5	±5	±5	±5

## Supply

Voltage	VDC	22 ... 30	22 ... 30	22 ... 30	22 ... 30	22 ... 30	22 ... 30
Constant current	mA	2 ... 18	2 ... 18	2 ... 18	2 ... 18	2 ... 18	2 ... 18

## Construction

Sensing element		Ceramic	Ceramic	Ceramic	Ceramic	Ceramic	Ceramic
Housing/base	material	Titanium	Titanium	Titanium	Titanium	Titanium	Titanium
Sealing-housing/connector (EN 60529)	seal	Hermetic	Hermetic	Hermetic	Hermetic	Hermetic	Hermetic
Connector	Type 8764BxAx Type 8764BxBx	type	M4.5, 4 pin ¼-28, 4 pin	M4.5, 4 pin ¼-28, 4 pin	M4.5, 4 pin ¼-28, 4 pin	M4.5, 4 pin ¼-28, 4 pin	M4.5, 4 pin ¼-28, 4 pin
Ground isolated	yes/no	yes	yes	yes	yes	yes	yes
Mass	Type 8764BxAB Type 8764BxAT Type 8764BxBB Type 8764BxBT	grams	5.9 6.0 6.1 6.2	5.9 6.0 6.1 6.2	4.9 5.0 5.1 5.3	4.9 5.0 5.1 5.3	4.9 5.0
Mounting torque	N·m [in·lbf]	0.7±0.07 [6.5±0.7]	0.7±0.07 [6.5±0.7]	0.7±0.07 [6.5±0.7]	0.7±0.07 [6.5±0.7]	0.7±0.07 [6.5±0.7]	0.7±0.07 [6.5±0.7]

1 g = 9.80665 m/s<sup>2</sup>, 1 in = 25.4 mm, 1 Gram = 0.03527 oz, 1 lbf-in = 0.113 N·m

### Mounting

Reliable and accurate measurements require that the mounting surface be clean and flat. It is recommended that the sensor be mounted using the supplied isolated mounting screw. The instruction manual for Type 8764B... provides detailed information regarding mounting surface preparation.

### Accessories included

- |                                     | <b>Type</b> |
|-------------------------------------|-------------|
| • 4–40x½" isolated mounting screw   | 8446AE2     |
| • Mounting wax                      | 8432        |
| • 2.5x12 mm isolated mounting screw | 8446AM3     |
| • ISO 17025 Calibration Certificate |             |

### Optional cables

- |   | <b>Type</b> |
|---|-------------|
| • Fluoropolymer jacketed cable, M4.5, 4 pin (neg.) to ¼–28, 4 pin (pos.); (1784AK02 length = 0,5. For other special length use 1784AK02sp)              | 1784AK02    |
| • Fluoropolymer jacketed breakout cable, M4.5 4 pin (neg.) to 3x BNC (pos.); (xx = length: 1, 3, 5 & 10 meters)   | 1784BxxK03  |
| • Fluoropolymer jacketed breakout cable, ¼–28, 4 pin (neg.) to 3x BNC (pos.); (xx = length: 3, 5 & 10 meters. For other special length, use 1765CK04sp) | 1756CxxK04  |
| • Flexible silicone jacketed breakout cable, ¼–28, 4 pin (neg.) to 3x BNC (pos.); (xx = length: 1, 3, 5, 10 meters)                                     | 1734AxxK04  |

### Optional accessories

- |                                     | <b>Type</b> |
|-------------------------------------|-------------|
| • Adhesive mounting base, 4-40 thd. | 8462K01     |
| • Adhesive mounting base, M2.5 thd. | 8462K02     |

### Ordering key

Type 8764B... 

#### Measuring range

±50 g	<b>050</b>
±100 g	<b>100</b>
±250 g	<b>250</b>
±500 g	<b>500</b>
±1,000 g	<b>1K0</b>
±2,000 g	<b>2K0</b>

#### Connector

M4.5, 4 pin (pos.)	<b>A</b>
Standard, ¼–28, 4 pin (pos.) [only ±50g, ±100g, ±250g, and ±500g ranges]	<b>B</b>

#### Variants/TEDS templates

Base model (without TEDS)	<b>B</b>
Default, IEEE 1451.4 V0.9 Template 0 (UTID 1)	<b>T</b>
IEEE 1451.4 V0.9 Template 24 (UTID 116225)	<b>T01</b>
LMS Template 117, Free format Point ID	<b>T02</b>
LMS Template 118, Automotive For- mat (Field 14 Geometry = 0)	<b>T03</b>
LMS Template 118, Aerospace Format (Field 14 Geometry =1)	<b>T04</b>
P1451.4 v1.0 Template 25 - Transfer Function Disabled	<b>T05</b>
P1451.4 v1.0 Template 25 - Transfer Function Enabled	<b>T06</b>

