

## KiTorq Rotor

Type 4551A...

### Torque measuring unit (rotor) for a torque measuring flange

KiTorq Rotor Type 4551A... for measuring highly dynamic torques.

- Combinations of various rotors and stators
- Wireless transmission
- High precision, maximum dynamics
- High resolution rotational speed or angle measurement

#### Description

The KiTorq System is a torque measuring flange system, consisting of the Type 4551A... KiTorq Rotor torque measuring unit and the Type 454xA... KiTorq Stator torque evaluation unit. The rotors and stators of the KiTorq System that have the same speed option can be used in any combination with each other.

Rotational speed or angle measurement up to 8 192 pulses per revolution. Additional measurement of absolute zero value (called Z-Impulse) by means of which absolute angle positions can be determined. Using the ordering key, the Type 4551A... rotor can be purchased individually or as a calibrated torque measurement chain, together with a KiTorq Stator. The stator detects automatically a change of rotor, and sets the required parameters.

All KiTorq Rotors capture the torque using strain gages (DMS). The signal that they generate is amplified and then processed at approx. 35 kSample. The high sampling rate means that very high dynamic torques can be measured.

#### KiTorq Stator Type 454x...

The torque evaluation unit supplies power to the KiTorq Rotor and receives measurement values from it. The evaluation unit has an integrated speed measuring unit and provides various signal outputs, depending on type.

#### Calibration

Various calibration options are available for the configurable output signals of the KiTorq System. The calibration takes place on a high-precision calibration system that is traceable to national standards.

#### Application

The properties of the Type 4551A... KiTorq Rotor make it predestined for applications in test bench engineering, such as electric motor, gear, pump, and combustion engine test stands.

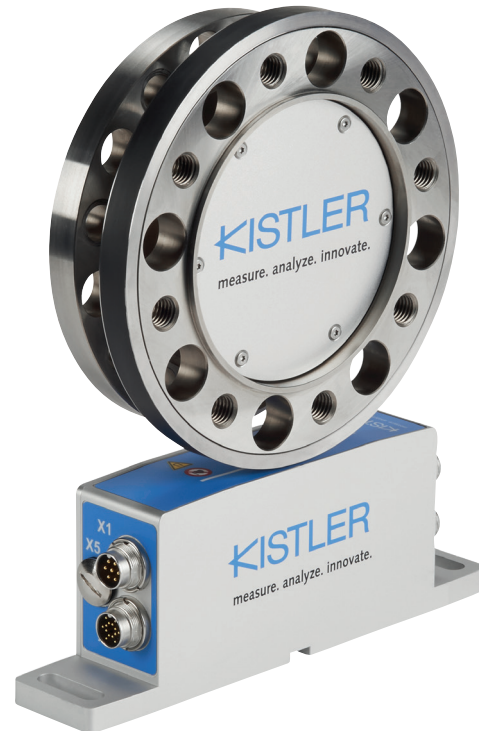

#### General technical data

Rated torque $M_{nom}$	N·m	50, 100, 200, 500
Rated torque $M_{nom}$	kN·m	1, 2, 3, 5
Nominal speed $n_{nom}$ at 50, 100 N·m	min <sup>-1</sup>	20 000
Nominal speed $n_{nom}$ at 200 N·m	min <sup>-1</sup>	17 000
Nominal speed $n_{nom}$ at 500 N·m, 1 kN·m	min <sup>-1</sup>	14 000
Nominal speed $n_{nom}$ at 2 and 3 kN·m	min <sup>-1</sup>	11 000
Nominal speed $n_{nom}$ at 5 kN·m	min <sup>-1</sup>	9 000
Operating temperature range (rated temperature range $T_{nom}$ )	°C	10 ... 60
Service temperature range	°C	0 ... 70
Storage temperature range	°C	-25 ... 80
Protection class (IEC 60529)		IP54

## Mechanical data and load limits Type 4551A...

Size/Rated torque $M_{nom}$	N·m	50	100	200	500				
	kN·m	–	–	–	–	1	2	3	5
<b>Mechanical data</b>									
Torsional rigidity $C_T$	kN·m/rad	221		300	877	1322	2340	3106	4502
Torsion angle at $M_{nom}$	°	0.013	0.026	0.038	0.033	0.043	0.049	0.055	0.064
Mass moment of inertia of the rotor around rotation axis	kgm <sup>2</sup>	0.0019		0.004	0.01	0.01	0.022	0.028	0.084
Proportionate mass moment of inertia around the axis on the measuring side	kgm <sup>2</sup>	0.0012		0.003	0.006	0.006	0.013	0.016	0.048
Resonance frequency of the rotor (torsion vibration)	kHz	2.05		1.66	1.95	2.33	2.19	2.32	1.49
Loading limits <sup>1)</sup>									
Limiting torque $M_{opr}$ , related to $M_{nom}$ <sup>2)</sup>	%	200							
Rupture torque $M_{ruptr}$ , related to $M_{nom}$ <sup>2)</sup>	%	>400						>360	
Alternating torque $M_{dyn}$ <sup>3)</sup>	%	±100						±80	
Max. bending torque (radial axis) $M_b$ <sup>4)</sup>	N·m	25	40	50	120	120	220	230	300
Longitudinal load limit $F_A$ <sup>4)</sup>	kN	1.5	3	3	4	6	8	12	14
Transverse load limit $F_Q$ <sup>4)</sup>	kN	0.4	1	1	3.2	5.5	6	9	12
Stiffness in case of bending moment around a radial axis $c_b$	kN·m/°	0.5		0.6	1.1	2.2	2.5	4	6.7
Stiffness in axial direction $c_a$	kN/mm	176		188	267	375	400	462	483
Stiffness in radial direction $c_r$	kN/mm	159		161	200	275	300	391	546
Allowed deviation of plane parallelism at max. bending torque (at $\varnothing D$ )	mm	<0.3							
Max. stroke at limit longitudinal force	mm	<0.03							
Additional max. runout error at transverse load limit $F_Q$	mm	<0.025							
Mass									
Rotor	kg	1.2		1.7	2.7	2.9	4.1	5.2	10.6
Stator	kg	0.7							
Balancing class according DIN ISO 1940	Q	G 2.5							
Max. allowed axial misalignment between rotor and stator <sup>5)</sup>	mm	±1							
Max. allowed air gap between rotor and stator $S_r$ <sup>5)</sup>	mm	1 ±0.5							
Concentricity radial on measuring side <sup>5)</sup>	mm	0.01		0.012	0.014		0.018		0.022

<sup>1)</sup> The effects of permissible parasitic forces (bending moment  $M_b$ , longitudinal  $F_A$  and lateral forces  $F_Q$ ) can be up to 0.3% of nominal torque. Each type of irregular stress ( $M_b$ ,  $F_A$  oder  $F_Q$ ) is only permitted up to its specific load limit, provided none of the others will occur at the same time. If this condition is not met, the limit values must be reduced. If 30% of  $M_b$  and  $F_Q$  occur at the same time, only 40% of  $F_A$  is permissible and the nominal (rated) torque must not be exceeded.

<sup>2)</sup> These values refer to static load.

<sup>3)</sup>  $M_{nom}$  should not be exceeded.

<sup>4)</sup> These values refer to static and dynamic load.

<sup>5)</sup> Operation out of range results in deviation of the rotation angle precision.

## General information Type 4551A...

Size/Rated torque $M_{nom}$	N·m	50	100	200	500				
	kN·m	–	–	–	–	1	2	3	5
<b>General data</b>									
<b>Electromagnetic compatibility (EMV)</b>									
Noise immunity (EN 61326-1, Table 2)									
Electromagnetic field (AM)	V/m	10							
Magnetic field	A/m	100							
Electrostatic discharge by contact (ESD)	kV	8							
Electrostatic discharge in air (ESD)	kV	4							
Fast transients (burst)	kV	1							
Surge voltages (surge)	kV	1							
Cable bound noise (AM)	V	10							
Emission (according to EN 61326-1, Table 3)									
Radio interference voltage, radio interference power, Radio interference field intensity		Class B							
Protection class (IEC 60529)		IP54							
Operating temperature range ( $T_{nom}$ )	°C	10 ... 60							
Service temperature range	°C	0 ... 70							
Storage temperature range	°C	–25 ... 80							
Mechanical shock (EN 60068-2-27)									
Number of cycles		1 000							
Cycle duration	ms	3							
Acceleration shock	g	650							
Vibration stress in 3 axes (EN 60068-2-6)									
Frequency range	Hz	10 ... 2 000							
Loading duration	h	2.5							
Acceleration (Amplitude)	g	200							

## Technical data Type 4551A...

Size/Rated torque $M_{nom}$	N·m	50	100	200	500				
	kN·m	–	–	–	–	1	2	3	5
<b>Technical data</b>									
<b>Torque measuring system</b>									
Nominal speed $n_{nom}$	min <sup>-1</sup>	20 000	17 000	14 000	11 000	9 000			
<b>Measurement features in the measuring range 1:1 (single range) *</b>									
Accuracy class	–	0.05							
Typical linearity incl. hysteresis, referring to nominal sensitivity for max. torque in the range of:									
Between 0 % of $M_{nom}$ and 20 % of $M_{nom}$	% FSO	<±0.01							
>20 % of $M_{nom}$ and 60 % of $M_{nom}$	% FSO	<±0.02							
>60 % of $M_{nom}$ and 100 % of $M_{nom}$	% FSO	<±0.03							
Rel. standard deviation of repeatability	% FSO	<±0.03							
Temperature influence zero point	% FSO/10K	<±0.05							
Temperature influence nominal value	% FSO/10K	<±0.05							
<b>Nominal value (span betw. torque = zero and nominal torque)</b>									
Frequency output 240 kHz (standard)	kHz	120							
Voltage output	V	10							

Size/Rated torque $M_{nom}$	N·m	50	100	200	500				
	kN·m	–	–	–	–	1	2	3	5
<b>Technical data</b>									
<b>Torque measuring system</b>									
<b>Measurement features in the measuring range 1:5 / 1:10 *</b>									
Accuracy class	–	0.1							
Typical linearity incl. hysteresis, referring to nominal sensitivity for max. torque in the range of:									
Between 0 % of $M_{nom}$ and 60 % of $M_{nom}$	% FSO	<±0.04							
>60 % of $M_{nom}$ and 100 % of $M_{nom}$	% FSO	<±0.06							
Rel. standard deviation of repeatability	% FSO	<±0.06							
Temperature influence zero point	% FSO/10K	<±0.1							
Temperature influence nominal value	% FSO/10K	<±0.1							

\* Compliance of the values within the nominal temperature range ( $T_{nom}$  = +10 °C ... +60 °C)

## Electrical data Type 4551A...

Size/Rated torque $M_{nom}$	N·m	50	100	200	500				
	kN·m	–	–	–	–	1	2	3	5
<b>Technical data</b>									
<b>Torque measuring system</b>									
<b>Output signal</b>									
Frequency output (standard)	kHz	240 ±120							
Voltage level of the frequency output	V	+4.2* ... +5* / +24							
Voltage output	V	–10 ... +10							
Tolerance of sensitivity (voltage/frequency)	%	±0.1							
Load resistance	kΩ	>10							
Long term drift 48 h (analog signal)	% FSO	<0.03							
Long term drift 48 h (digital signal)	% FSO	<0.01							
Cut-off frequency (–3 dB)	kHz	10							
Sampling rate	kSample	35							
<b>Noise with low pass filter with cutoff frequency (–3 dB) in measuring range 1:1</b>									
1 000 Hz	% FSO	<±0.05							
<b>Group delay time (all outputs)</b>									
... in case of 10 kHz between signal input torque to signal output	ms	<0.22							
... in case of 1 kHz between signal input torque to signal output	ms	<1.12							
<b>Signal when torque = zero</b>									
Frequency output 240 kHz	kHz	240							
Voltage output	V	0							
<b>Maximum control range</b>									
Frequency output	kHz	6 ... 360							
Voltage output	V	–11 ... +11							
<b>Resolution</b>									
Frequency signal 100 kHz	Hz	1							
Voltage signal	mV	0.4							
<b>Control input**</b>									
"On"	V	3.5 ... 30							
"Off"	V	0 ... 2							
Torque control signal	% FSO	100 ±0.2							

\* According to revision of the stator (protection circuit)

\*\* valid for analog and frequency output

Size/Rated torque $M_{nom}$	N·m	50	100	200	500				
	kN·m	–	–	–	–	1	2	3	5
<b>Torque measuring system</b>									
<b>Power supply</b>									
Nominal supply voltage $U_b$	V	18 ... 30							
Nominal input power rating	W	<20							
Permitted ripple of supply voltage	mV <sub>ss</sub>	200							
Current consumption during measuring operation at $U_b = 24$ V	A	<0.8							
Recommended max. cable length to guarantee the signal quality	m	5							
Connectors for electrical connection	–	depending on stator type							

## Rotation speed/rotation angle measuring system Type 4551A...

Size/Rated torque $M_{nom}$	N·m	50	100	200	500				
	kN·m	–	–	–	–	1	2	3	5
<b>Rotation angle measuring system with Z-Reference pulse N2/N3</b>									
Measuring system		Magnetic, via GMR sensor and pole wheel							
Amount of output pulses per turn N (depending on n and $f_{out}$ )	–	1 ... 8 192							
Maximum position deviation of the poles	$\mu\text{m}$	$\pm 100$							
Group delay time between signal input rotation to signal output	ms	<0.1							
Load resistance	k $\Omega$	$\geq 2$							
Minimum rotation for sufficient pulse stability Rotation angle (TTL)	$\text{min}^{-1}$	>0							
Output signal (TTL)	V	5							
Max. jitter per edge	°	$\pm 0.03$							
Jitter of the oscillation period	%	$= J[^\circ] * N / 180^\circ * 100$							
Maximum permitted output frequency $f_{out}$	kHz	500 <sup>1)</sup>							
Amount of reference pulses per turn	–	1							
Reference pulse width, $B_i$	°	0.25 x oscillation period							

<sup>1)</sup> Maximum numbers of output pulses  $N^{max} = \text{maximum allowable output frequency } f_{out} \text{ (Hz)} \times 60 / \text{rotational speed } n \text{ (min}^{-1}\text{)}$ .  
 With 8 192 pulses means a maximum speed of 3 660  $\text{min}^{-1}$

**Dimensions KiTorq System Type 4551A...**

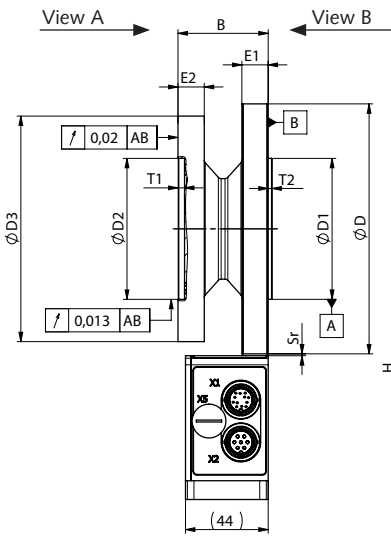

Fig. 1: Dimension drawing side view KiTorq System

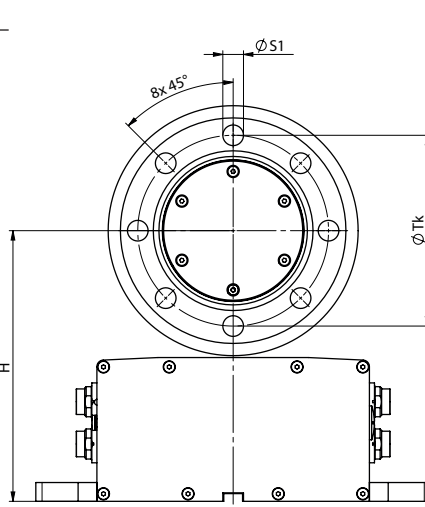

Fig. 2: Dimension drawing View A, KiTorq System

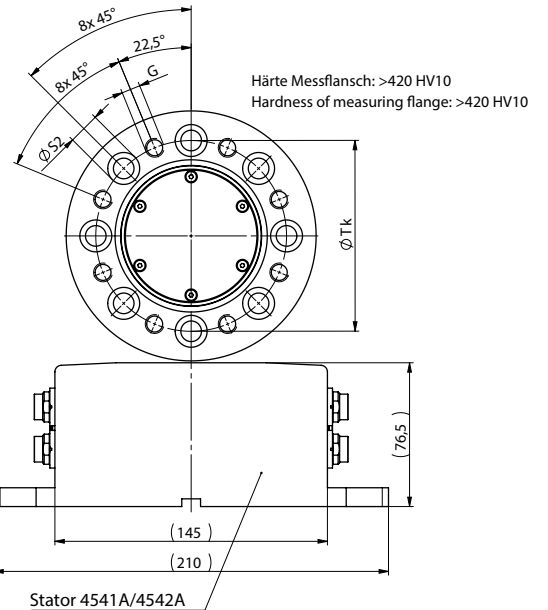

Fig. 3: Dimension drawing View B, KiTorq System

**Dimensions torque measuring unit KiTorq Rotor in mm**

(All dimensions without tolerances comply with ISO 2768-mH)

Type 4551A... Rated torque $M_{nom}$	<sup>1)</sup> N·m <sup>2)</sup> kN·m	50 <sup>1)</sup>	100 <sup>1)</sup>	200 <sup>1)</sup>	500 <sup>1)</sup>	1 <sup>2)</sup>	2 <sup>2)</sup>	3 <sup>2)</sup>	5 <sup>2)</sup>
$\varnothing D$	mm	112		134	167.5		201.5		253.5
$\varnothing D1_{g6}$		75		90	110		140		174
$\varnothing D2_{H6}$		75		90	110		140		174
$\varnothing D3$		100		120	155		190		238
E1		14		14	14		17		21
E2		10	12	12	14		14	17	21
T1 <sub>-0.2</sub>		2.5		2.5	3		4		4
T2 <sub>+0.2</sub>		3		3	3		3		3
$\varnothing Tk$		87		105	133		165		206
$\varnothing S1$		6.4		8.5	13		15		19
$\varnothing S2$		11		13.7	20		22		30
G (8x)		M6		M8	M12		M14		M18
H <sup>3)</sup>		133.5		144.5	161.25		178.25		204.25
B		34		34	40.5	48	46	55	64

<sup>3)</sup> Note: consider maximum permitted radial air gap!

4551A\_003-169e-08.20

**Application examples**

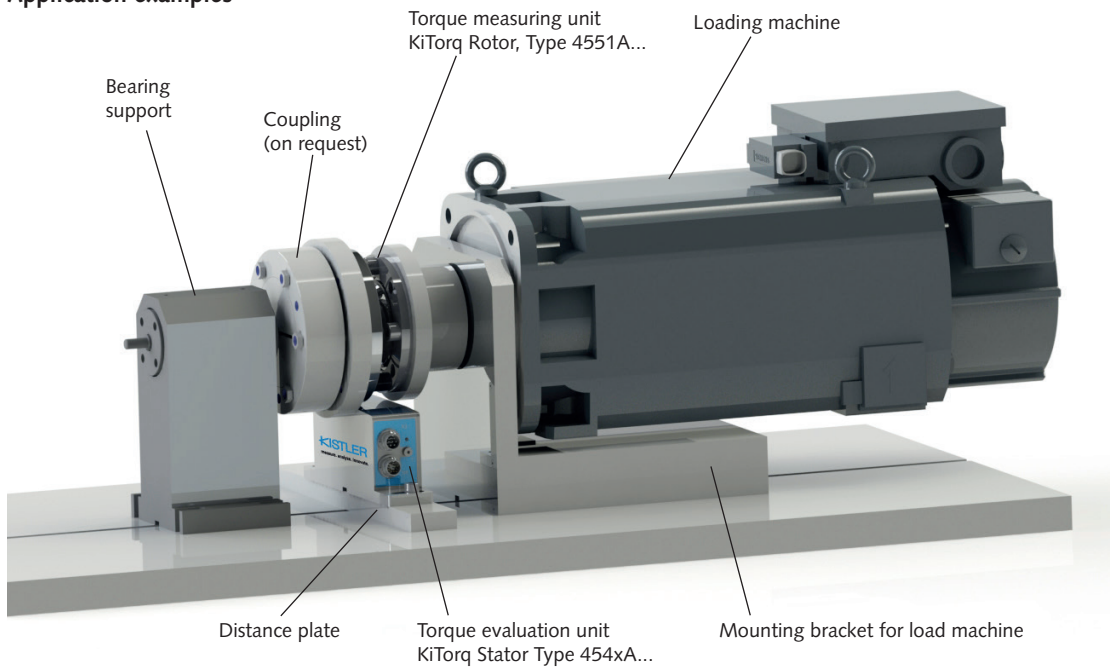
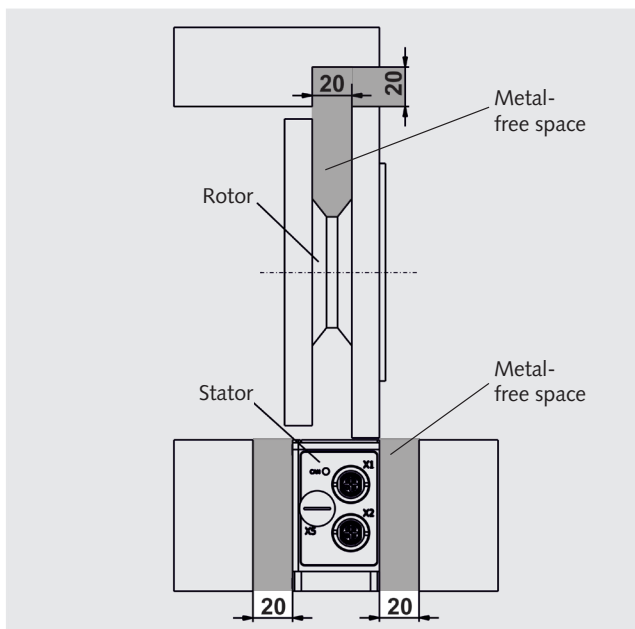

Fig. 4: Example of application with KiTorq

**Metal-free space**



**Installation according to system description 002-566**

Please note that there should be no piece of metal inside the „metal-free space“. Any metal could disturb the energy transmission between rotor and stator and could lead into signal disturbance.

Caution: Consider metal free space!

4551A\_003-169e-08.20

Fig. 5: Example of application metal-free space



## Mounting

### Rotor screw connection, mounting screws

Nominal torque $M_{nom}$	N·m kN·m	50 / 100	200	500	1	2	3	5
Thread		M6	M8	M12	M14			M18
Property class		12.9						
Minimum mounting depth	mm	6	8	12	12	14	14	18
Maximum mounting depth <sup>1)</sup>	mm	16	16	16	16	16	19	23
Fastening torque $M_A$	N·m	14	34	80	115	140	190	400

<sup>1)</sup> Important: The maximum mounting depth must never be exceeded!

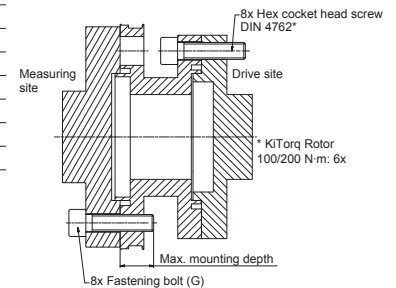

## Calibration

**Standard calibration:** The rotor is calibrated per WKS 1 as a standard. If ordered as a measurement chain with a KiTorq Stator, the rotor and stator are calibrated as a torque measurement chain according to WKS 1.

The following signals are set as standard:

- Frequency: 240 kHz  $\pm$ 120 kHz
- Analog:  $\pm$ 10 V

**Special calibration:** Upon request, additional calibrations can be ordered (e.g., second measuring range, another frequency, DAKKS calibration, ...). More information is available in the data sheet for the desired Type 454xA... KiTorq Stator.

The torque measurement chain, consisting of the KiTorq Rotor and KiTorq Stator, has its own separate calibration certificate and a serial number.

If one of the components is replaced (e.g., with a KiTorq Rotor with a different measuring range), then the virtual calibration values for the new measurement chain can be calculated from the individual calibration certificates for the rotor and stator.

All output settings can be changed afterward by the customer. The calibration certificates apply only to the settings at delivery, according to the order.

### Definition of calibration terms:

- **WKS 1:** Works calibration at 5 points right, 3 points left
- **WKS 2:** Works calibration at 5 points right and left, and repeat series
- **DAkKS:** Calibration per DIN 51309

Our calibration service DAKKS-K-17650-01 provides traceable calibrations for torque sensors from all manufacturers.

### Optional accessories

- Adapter flanges and couplings (on request)

### Type

2300A...

## Ordering key

Type 4551A

### Nominal torque in N·m

50	050
100	100
200	200
500	500
1 000	1k0
2 000	2k0
3 000	3k0
5 000	5k0

### Stator

Without	S00
KiTorq Stator Type 4541A...	S10
KiTorq Stator Type 4542A... PROFINET	S2A
KiTorq Stator Type 4542A... PROFIBUS	S2B
KiTorq Stator Type 4542A... CANopen	S2C
KiTorq Stator Type 4542A... EtherCAT	S2D
KiTorq Stator Type 4542A... EtherNet/IP	S2E

### Speed/Rotating angle

1x60 pulses per revolution + Z-pulse	N2
Rotational speed or angle measurement up to 8 192 pulses per revolution + Z-pulse	N3

### Calibration

WKS 1 single range	KA0
WKS 1 dual range 1:1 and/or 1:10	KA1
WKS 1 dual range 1:1 and/or 1:5	KA2
WKS 2 single range	WA0
WKS 2 dual range 1:1 and/or 1:10	WA1
WKS 2 Dual range 1:1 and/or 1:5	WA2
DAkS 5 – single range, 5 meas. points	DK5
DAkS 8 – single range, 8 meas. points	DK8
DAkS – Dual range, 5 Meas. points 1:1 and 1:10	D51
DAkS – Dual range, 5 Meas. points 1:1 and 1:5	D52
DAkS – Dual range, 8 Meas. points 1:1 and 1:10	D81
DAkS – Dual range, 8 Meas. points 1:1 and 1:5	D82

4551A\_003-169e-08.20