

Instruction Manual

**Torque Measuring
Flange
Type 4510B...**

Compatible with
Firmware-Version
Stator: >V2.06
Rotor: >V1.9

CE

KISTLER

measure. analyze. innovate.

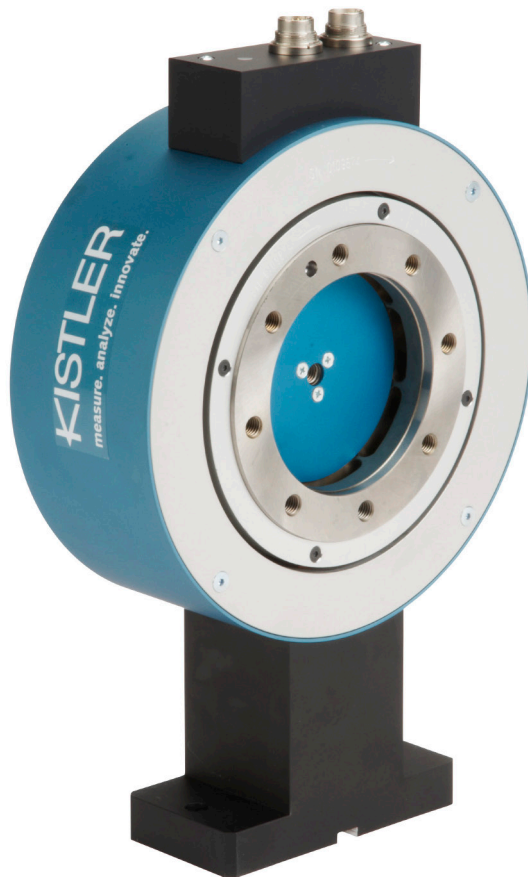

Instruction Manual

**Torque Measuring
Flange
Type 4510B...**

Compatible with
Firmware-Version
Stator: >V2.06
Rotor: >V1.9

CE

Foreword

This manual applies to the torque measuring flange Type 4510B... .

The instruction manual must be kept on hand for future use, and must be available at the site of implementation of the Torque measuring flange, as needed.

The specifications in this manual can change at any time without prior notification. Kistler reserves the right to improve and to change the product for the purpose of technical progress without the obligation to inform persons and organizations as the result of such changes.

Original language of these operating instructions: German

©2009 ... 2014 Kistler Group. All rights reserved.

Kistler Group
Eulachstrasse 22
8408 Winterthur
Switzerland
phone +41 52 224 11 11
fax +41 52 224 14 14
info@kistler.com
www.kistler.com

Product Center
Torque measuring flanges, NC Joining Systems,
Force-Displacement Monitoring, Test Stand Systems

Kistler Lorch GmbH
Maierhofstrasse 35
73547 Lorch
Germany
phone +49 7172 184 0
fax +49 7172 184 400
info.klr@kistler.com

Content

1.	Introduction	4
2.	Important Information.....	5
2.1	Disposal Instructions for Electrical and Electronic Equipment	5
3.	Application and Typical Features	6
4.	Description of the Measuring System	7
4.1	Mechanical Design	7
4.2	Electrical Design	7
4.2.1	Speed Measurement with 60 Pulses	9
5.	Electrical Connection of Torque Measuring Flange.....	10
5.1	Supply	10
5.1.1	Power Consumption of the Torque Measuring Flange with Different Supply Voltages	10
5.2	Principle of Galvanic Isolation in the Torque Measuring Flange	11
5.3	Plug Allocation of the 12 pin Built-in Standard Connector A	12
5.4	Plug Allocation of the 7 pin Built-in Standard Connector B.....	12
5.4.1	Measuring Range Selection	13
5.4.2	Digital Output, Measuring Value via RS-232C Interface.....	13
5.4.3	Connection Diagram Standard Sensor	14
5.4.4	Pin Allocation of the Built-In Connector A and B (standard)	15
6.	Connection Cable.....	16
6.1	Laying of the Measuring Cable.....	17
6.2	Advice for Safe Electrical Installation.....	18
7.	Mechanical Installation of the Torque Measuring Flange	19
7.1	Installation Proposals.....	20
7.1.1	Shaft Tolerance	20
7.1.2	Aligning Stator to Rotor.....	20
7.1.3	Installation and Removal Instructions for Shrinking Disks	21
7.2	Suggestion for Installation	23
7.2.1	Connection of Rotor, Fastening Bolts	23
8.	Electrical and Mechanical Commissioning.....	24
8.1	Operating LED	24
8.2	Adjusting and Calibrating the Torque measuring flange	25
8.3	Mechanical Calibration.....	26
8.3.1	Set-up of a Simple Calibration Device.....	26
8.3.2	Calculation Example, Lever Arm Length	27
9.	Making Torque Measurements	28
9.1	Switch on the Torque measuring flange	28
9.2	Qualities After Switching Measuring Range	28

10.	RS-232C Communication	29
10.1	Interface Parameters	30
10.1.1	Conventions and Syntax	30
10.1.2	Error Messages	32
10.1.3	Measuring Rates, Reaction Times	33
10.1.4	Requesting Torque Values Through RS-232C Command	34
10.1.5	Requesting Torque Measuring Values via External Triggering	35
10.2	Typical Measuring Sequence	36
10.3	Configuration Commands	37
10.3.1	Range Selection	37
10.3.2	Control Signal (Calibration Signal) On or Off	38
10.3.3	Value Query – Configuration for the MEAS Command	39
10.3.4	Defining the Output Format	40
10.3.5	Determining the Trigger Mode	41
10.3.6	Determining Sensor Data	42
10.4	Measuring Commands	45
10.4.1	Transmitting Torque and Temperature Measuring Quantity	45
11.	Maintenance	47
12.	Repairing the Measuring Shaft	47
13.	Technical Data	48
13.1	Mechanical Basic Data	48
13.2	General Electrical Specifications	48
13.3	Electrical Measuring Data – Standard Measuring Range 1:1	49
13.4	Electrical Measuring Data – Extended Measuring Range 1:5, 1:10	49
14.	Dimensions	50
15.	Ordering Key and Accessories	52
16.	Declaration of Conformity	53
17.	Index	54

Total Pages 54

1. Introduction

Please take the time to thoroughly read this instruction manual. It will help you with the installation, maintenance, and use of this product.

To the extent permitted by law Kistler does not accept any liability if this instruction manual is not followed or products other than those listed under Accessories are used.

Kistler offers a wide range of products for use in measuring technology:

- Piezoelectric sensors for measuring force, torque, strain, pressure, acceleration, shock, vibration and acoustic-emission
- Strain gage sensor systems for measuring force and torque
- Piezoresistive pressure sensors and transmitters
- Signal conditioners, indicators and calibrators
- Electronic control and monitoring systems as well as software for specific measurement applications
- Data transmission modules (telemetry)
- Electromechanical NC joining modules and force-displacement monitors
- Test stand systems for electric motors and gear units for laboratory, manufacturing, and quality assurance

Kistler also develops and produces measuring solutions for the application fields engines, vehicles, manufacturing, plastics and biomechanics sectors.

Our product and application brochures will provide you with an overview of our product range. Detailed data sheets are available for almost all products.

If you need additional help beyond what can be found either on-line or in this manual, please contact Kistler's extensive support organization.

2. Important Information

2.1 Disposal Instructions for Electrical and Electronic Equipment



Do not discard old electronic instruments in municipal trash. For disposal at end of life, please return this product to an authorized local electronic waste disposal service or contact the nearest Kistler Instrument sales office for return instructions.

3. Application and Typical Features

- Torque measuring flange with strain gage measuring system
- Digitalized wear-resistant measuring signal transmission
- Measurement of constant and variable torques
- Torque measurement on the rotating shaft
- Application in the laboratory, production and quality control
- Torque measuring flange for precision measurements
- With speed measurement
- 2-color LED for operating condition
- Galvanic isolation between supply and torque output signal

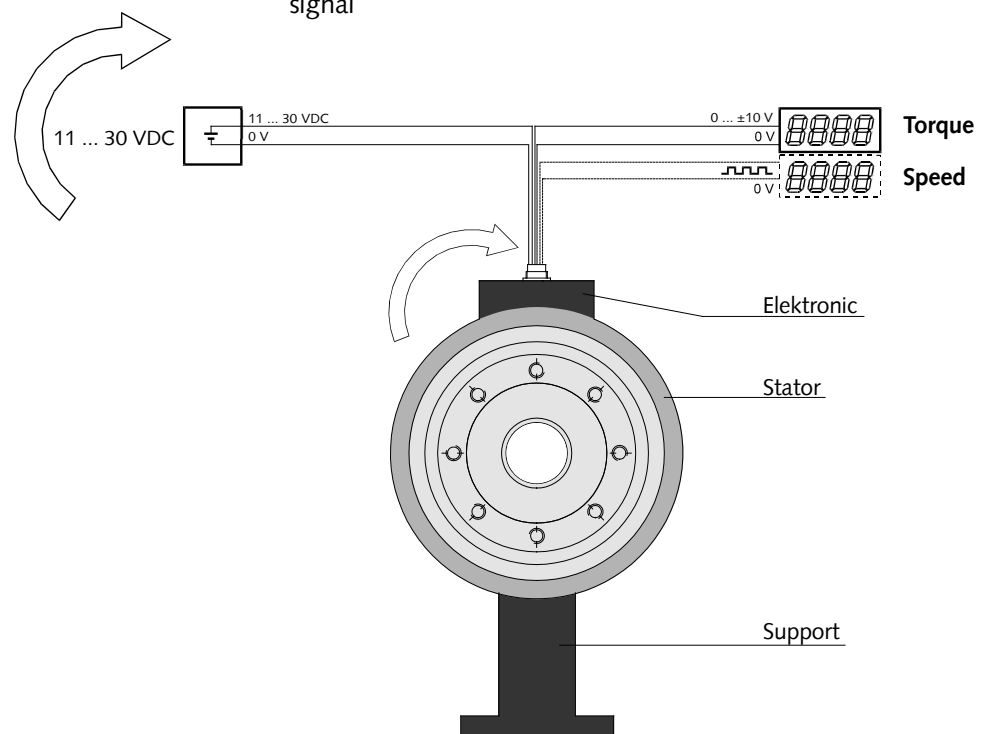

Fig. 1: Standard version of a torque measuring flange Type 4510B...

4. Description of the Measuring System

4.1 Mechanical Design

The torque measuring flange consisting of a stator with support and a rotating rotor.

On the measuring flange at the torsion section strain gages are arranged, as well as electronics with signal amplifier and A/D converter. In the connection box of the stator the stationary electronics for signal shaping are positioned. The stator provides various assembly possibilities.

4.2 Electrical Design

The following schematic diagram represents the principle of operation of a digital value transmission.

Feed of the electronics is performed by a DC voltage in the range of 11 ... 30 V ($\pm 25\%$). Free programmable controls (PLC) provide a DC voltage of 24 V, which may of course be utilized for feeding the torque measuring flange.

A crystal controlled power oscillator creates the system cycle and feeds the rotating electronics through concentric rotary transmitters.

In the rotating electronics this alternating voltage is rectified and stabilized. The measuring signal of the strain gage is increased and digitalized through a rapid serial A/D converter. The modulation with 1 MHz allows a back transfer through air-core coils.

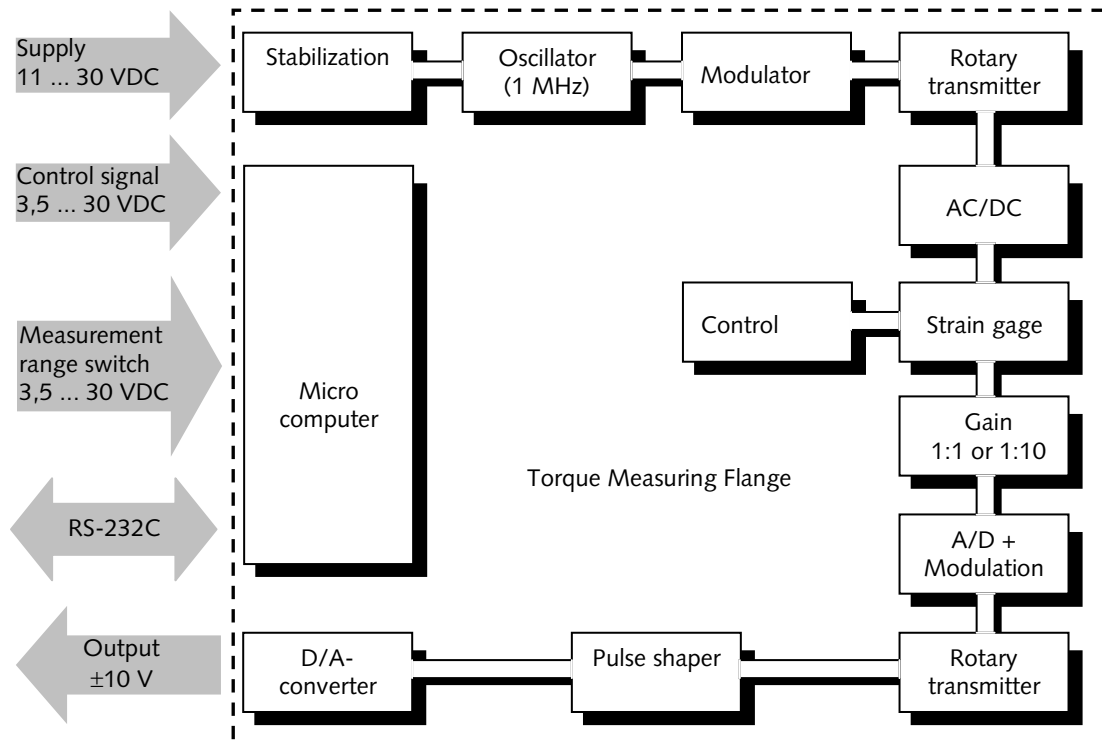

Fig. 2: Schematic block diagram of Torque measuring flange Type 4510B...

In the outside electronics the digitalized strain gage signal is reconverted into an analog signal of ± 10 Volt during the transmission.

Optionally a frequency-based signal can be produced. In addition there is the option of transmitting the torque-measuring signal through the RS-232C interface.

Through an external digital control signal a defined strain gage signal value can be activated on the shaft, which corresponds to the rated torque.

With an external digital measurement range signal the amplification of the strain gage amplifier can be switched.

4.2.1 Speed Measurement with 60 Pulses

The measuring of the speed of rotation is integrated in this torque measuring flange. This is realized by a pulse wheel with 60 pulses.

- A pulse wheel with 60 pulses. Raised sections on the wheel are detected with the aid of a magnetic sensor. This speed measurement system is provided as a standard feature

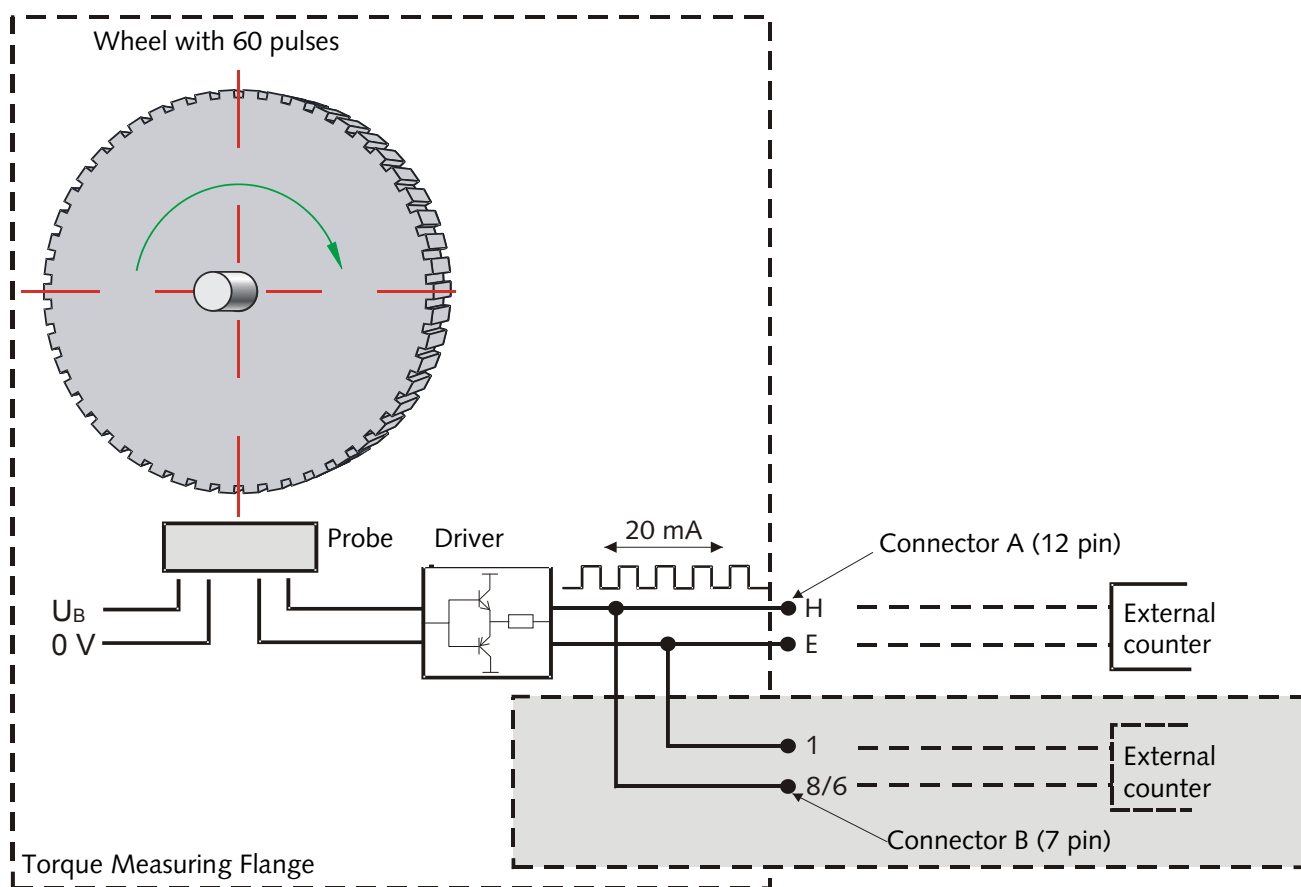

Fig. 3: Electrical circuit diagram of speed measurement with pulse wheel

5. Electrical Connection of Torque Measuring Flange

5.1 Supply

To supply torque measuring flange Type 4510B..., a supply voltage in the range of:

11 ... 30 VDC Direct Voltage

is necessary. The direct voltage is supplied to the integrated 12 pin connector on pin F (+U_B) and A (GND). The power consumption is approx. 2,5 W. The supply and torque output are electrically isolated in the torque measuring flange.

5.1.1 Power Consumption of the Torque Measuring Flange with Different Supply Voltages

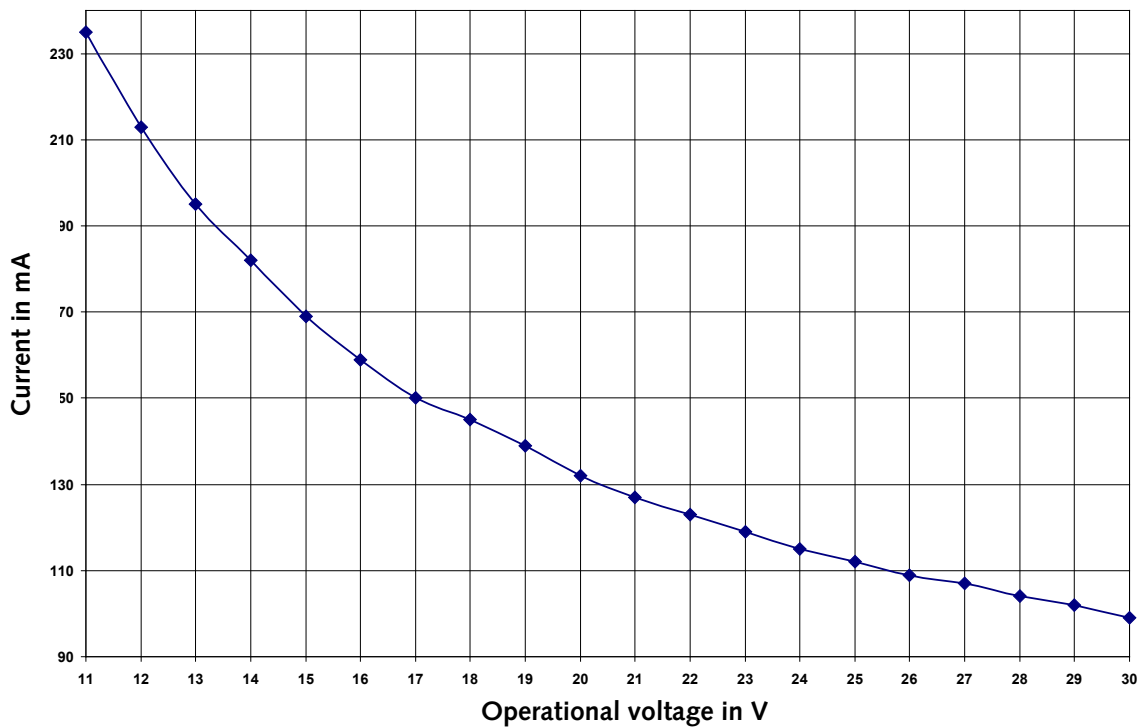

Fig. 4: Input current as a function of the input voltage

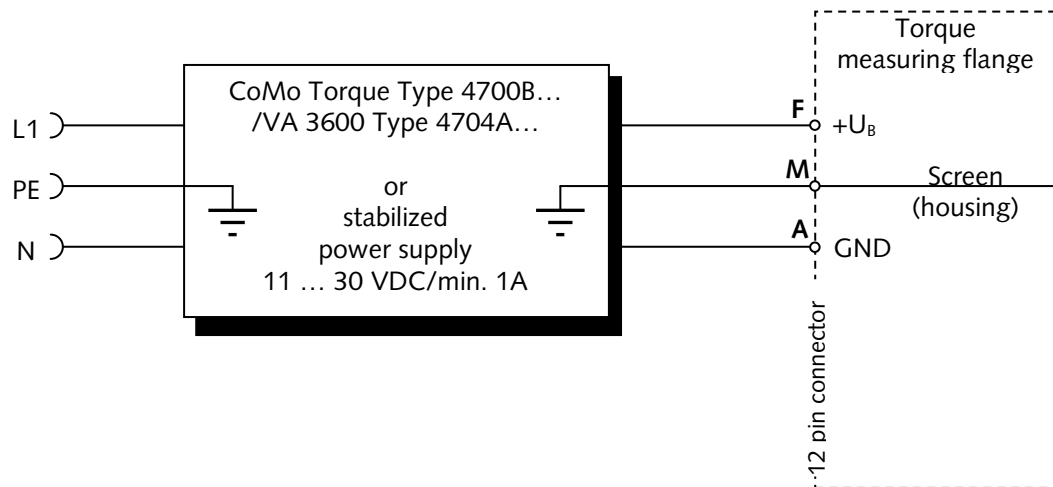

Fig. 5: Possible power supplier devices for Torque measuring flange

5.2 Principle of Galvanic Isolation in the Torque Measuring Flange

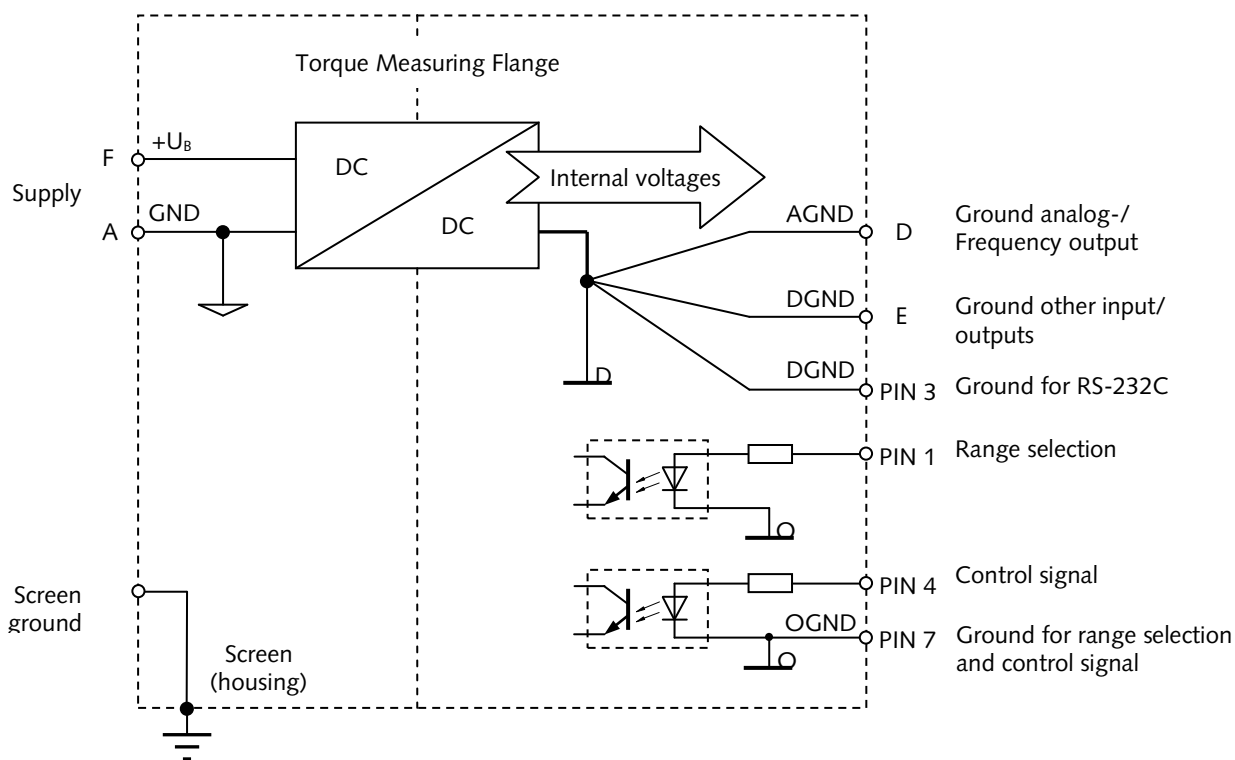
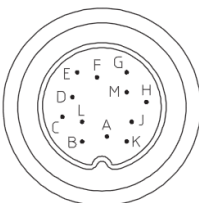

Fig. 6: Block diagram of galvanic isolation in the Torque measuring flange

5.3 Plug Allocation of the 12 pin Built-in Standard Connector A



Function	PIN	Description	
Supply	F	+U _B 11 ... 30 VDC, power consumption <5 W	
	A	GND Ground relating to +U _B	
Shield	M	In sensor connected to housing	
Torque output	C	U _A Voltage output B1 ±10 VDC bei ±M _{Nom} at >2 kΩ 10 VDC at control signal activation R _{i,c} = 10 Ω, output short circuit	Frequency B2 F _{A+} frequency signal 5 V (TTL)
	D	AGND Ground relating to U _A	AGND Ground relating frequency signal
Speed pulses	H	Track A Active, TTL-level	
	G	Not connected	
	J	Not connected	
100 % Control input	K	Control Off: 0 ... 2 VDC On: 3,5 ... 30 VDC R _{i,k} = 10 kΩ	
RS-232C interface to the CoMo Torque	B	TXD Serial send path of the torque sensor	
	L	RXD Serial receive path of the torque sensor	
Digital ground	E	DGND Ground relating to speed pulses, calibration/control input, RS-232C interface	

5.4 Plug Allocation of the 7 pin Built-in Standard Connector B

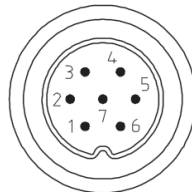

Function	PIN	Description
Measuring range selection	1	Gain Normal (1:1) with 0 ... 2 VDC Extended (1:5 / 1:10) with 3,5 ... 30 VDC
	2	For company internal functions, don't use!
Digital mass potential	3	DGND Ground relating to RS-232C interface
100 % control input	4	Control Off: 0 ... 2 VDC On: 3,5 ... 30 VDC
	5	TXD Serial send path of the torque sensor
RS-232C interface	6	RXD Serial receive path of the torque sensor
	7	OGND Ground relating for control

5.4.1 Measuring Range Selection

Must be:

- Option A1 (measuring range 1:10) or
- Option A2 (measuring range 1:5, technical data like 1:10)



All specifications are for the measuring range 1:10 and 1:5.

If the torque measuring sensor is additionally calibrated in the range of 1:10 at the factory, the requested range may be switched via PIN 1 and PIN 7.

Measuring range	logic condition	voltage level
1:1	PIN1 = 0	$U_{\text{PIN1,7}} = 0 \dots 2 \text{ V}$
1:10	PIN1 = 1	$U_{\text{PIN1,7}} = 3,5 \dots 30 \text{ V}$

For each measuring range the logic condition at PIN 1 must continue.

Optional the measuring range can be switched via the RS-232C interface.

5.4.2 Digital Output, Measuring Value via RS-232C Interface

Must be: Option D (RS-232C interface)

With this option torque values can be sent via the RS-232C interface. Additional notes are in the chapter "RS-232C communication".

5.4.3 Connection Diagram Standard Sensor

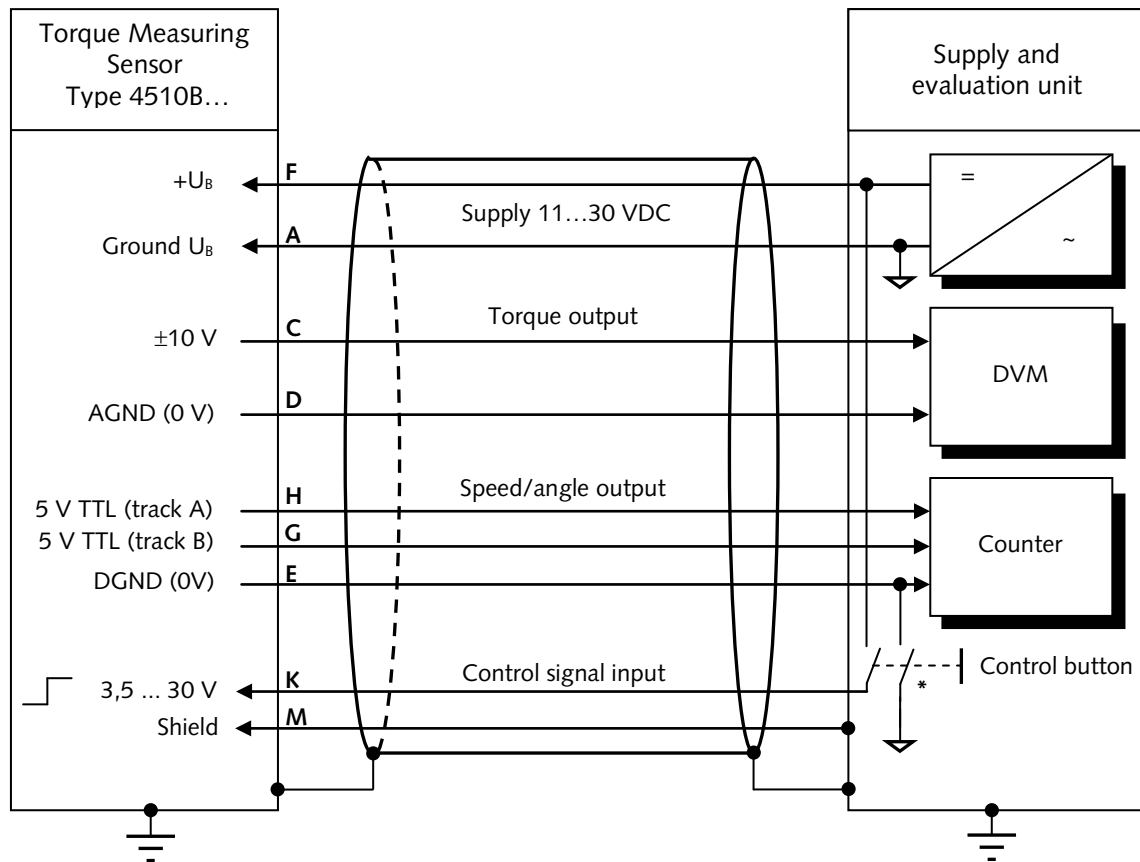

Fig. 7: Example for connecting standard Torque measuring flange Type 4510B... to the supply and evaluation unit

- **Screened measuring cable:** Item no. 7203, Mat. No.: 188935 (item no. 12497, Mat.-no.: 18008943 with opened ends)
- **Supply and evaluation unit:** e.g.: VA3600, CoMo Torque Type 4700B...
- **Built-in connector:** Binder series 680 type 09-0331-80-12 or corresponding, item no. 703.



The displayed connection example disables the galvanic isolation in the Torque measuring flange, if the control button is switched on (e.g. PLC relays). Avoid EMC noises on the measuring cable.

In order to avoid errors, please note if cables are longer than 10 m and conductors are distributed, that the speed signal is isolated from the torque signal by feeders, just as in the connector.

5.4.4 Pin Allocation of the Built-In Connector A and B (standard)

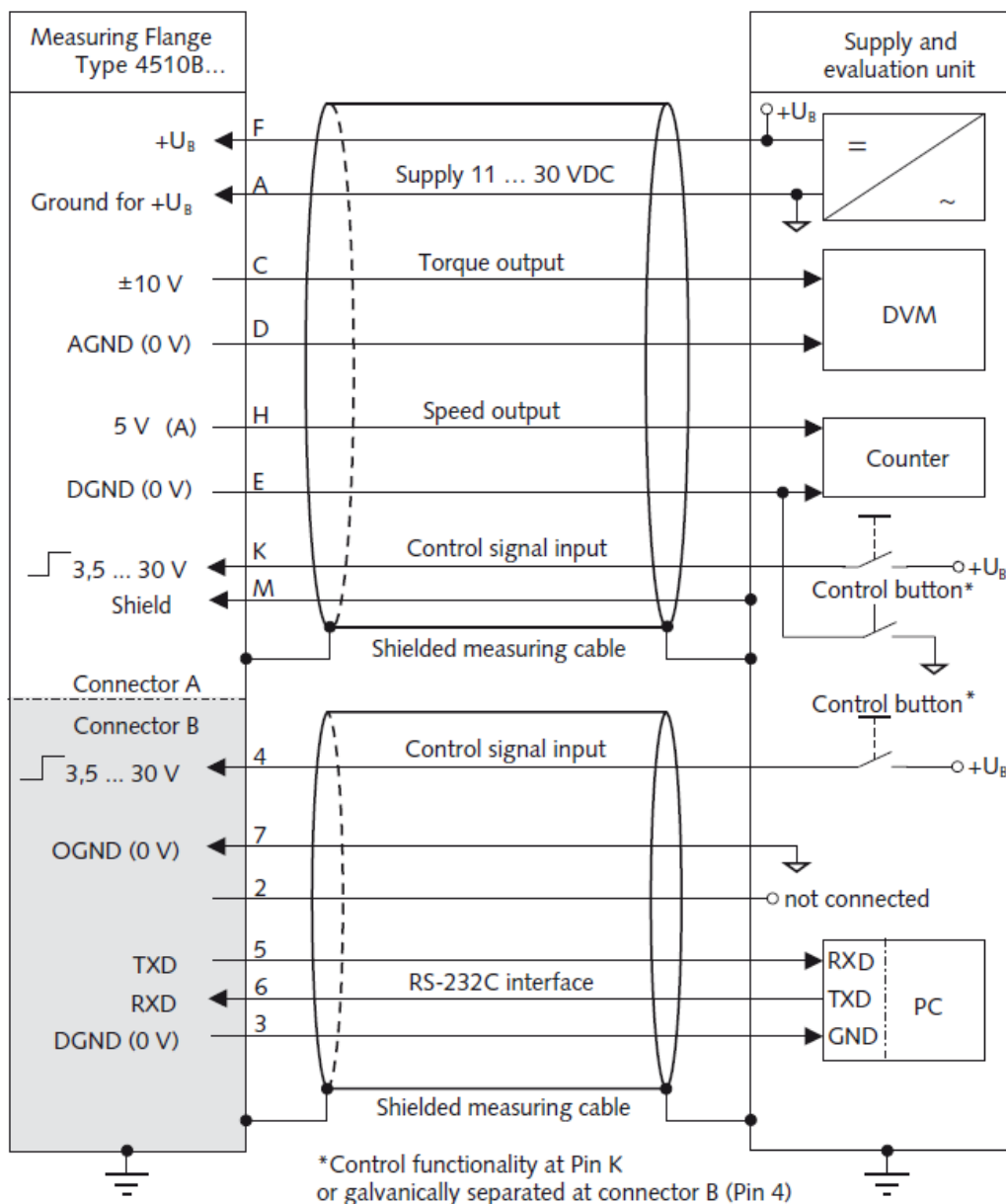
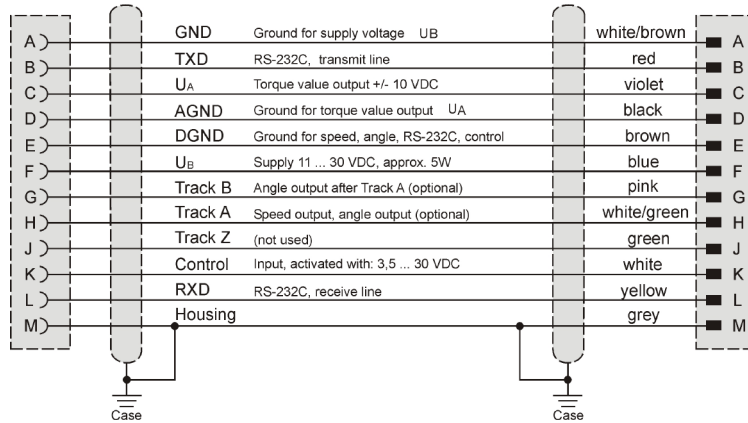
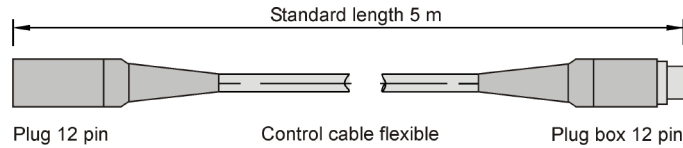

Fig. 8: Connection diagram of torque measuring flange Type 4510B... with one or both options range selection/RS-232C interface to supply and evaluation units

6. Connection Cable



Technical Data		Type KSM072030-5 Mat. No. 18008935
Connector		12 pin neg. – 12 pin pos.
Length	m	5 (other length on request)
Diameter	mm	6
Deg. of protection to IEC/EN 60529		IP40



Technical Data		Type KSM124970-5 Mat. No. 18008943
Connector		12 pin neg. – flying leads
Length	m	5 (other length on request)
Diameter	mm	6
Deg. of protection to IEC/EN 60529		IP40

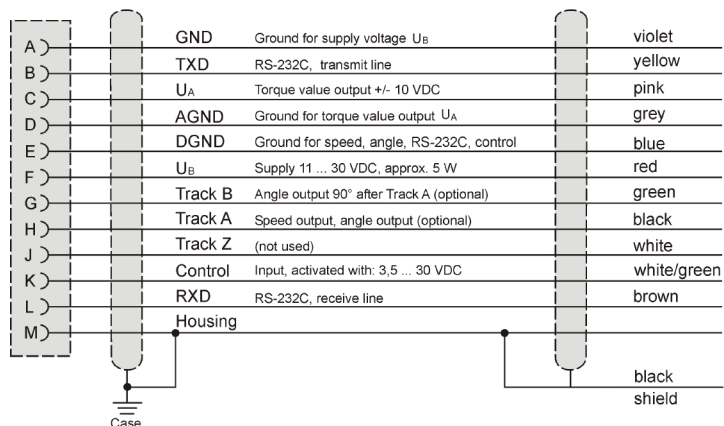
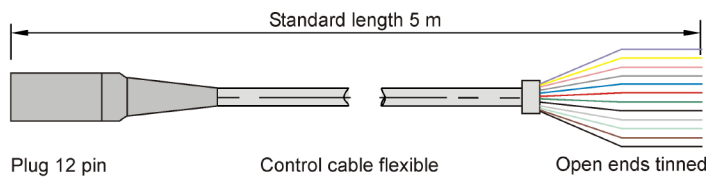



Technical Data		Type KSM219710-5 Mat. No. 18008996
Connector		7 pin neg. – flying leads
Length	m	5 (other length on request)
Diameter	mm	6
Deg. of protection to IEC/EN 60529		IP40

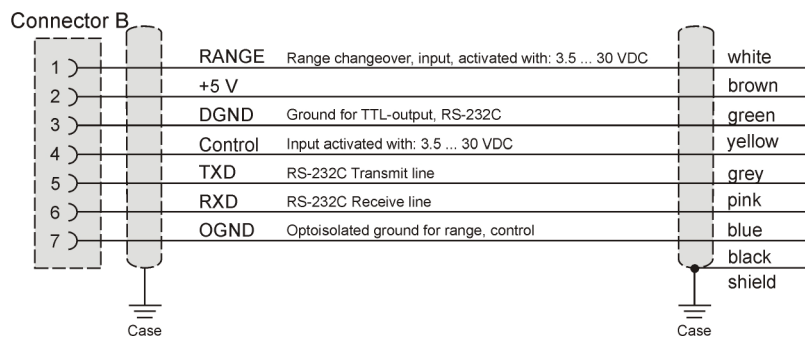
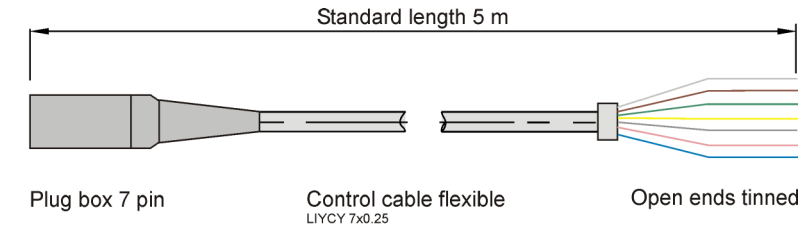

6.1 Laying of the Measuring Cable

- Do not lay parallel to power lines or control lines
- not in the vicinity of heavy electro-magnetic fields, e.g. transformers, welding devices, contactors, motors etc
- If this cannot be avoided, lay the measuring cable in a grounded armored conduit
- Excess lengths should be prevented. If it isn't possible to avoid, then do not lay excess lengths in closed loops

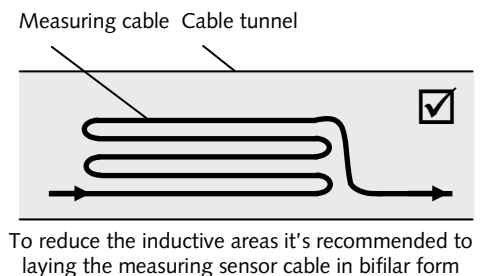
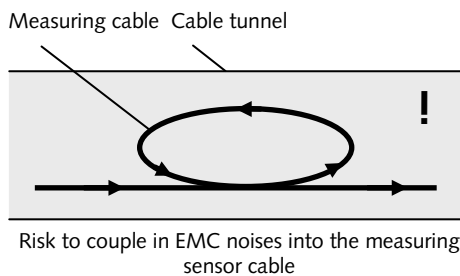

Fig. 9: Laying of the measuring cable

6.2 Advice for Safe Electrical Installation

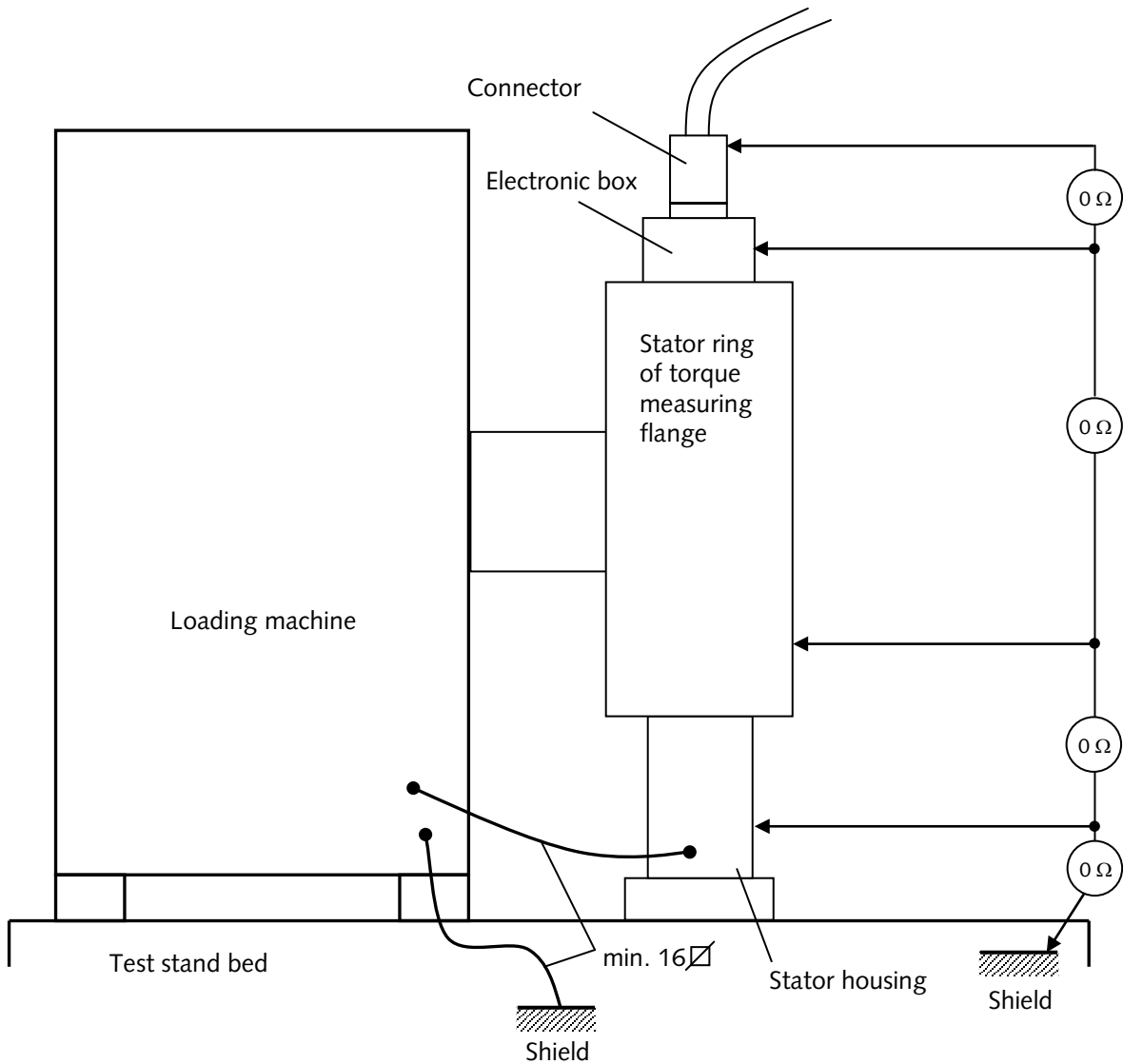

Fig. 10: Example for a safe electrical installation



Please ensure correct functioning of the shield for the connection cable!

To improve the electrical contact area between stator housing base and machine base, it's recommended to remove the anodization of the bottom of the stator housing

7. Mechanical Installation of the Torque Measuring Flange

There are different methods of installing the Torque measuring flange, depending on the application. Since very high lateral forces and bending moments may occur even at small axial displacement, the Torque measuring flange must always be mounted with couplings.

Generally:

- The plant must be secured with a burst protection corresponding to the machine protection law.
- We recommend calculating the shafting according to the torsion- and bending critical speeds. These speeds should be avoided during operation. For a safe operation of the unit we recommend to remain approx. 30 % below or above the critical speeds.
- After installation depending on speed the unit should be balanced according to DIN 2060.
- The machine vibrations should be checked according to VDI 2056.



Literature:

Dubbel pocket book for machine engineering, published by Springer

F. Holzweißig, H. Dresig, textbook of machine dynamics, published by Springer.

DIN 2056 evaluation rules for mechanic vibrations of machines.

7.1 Installation Proposals

7.1.1 Shaft Tolerance

The shaft on which the measuring flange is to be mounted must be manufactured with the tolerance h6 and must have a surface roughness $R_t \leq 16 \mu\text{m}$.

7.1.2 Aligning Stator to Rotor

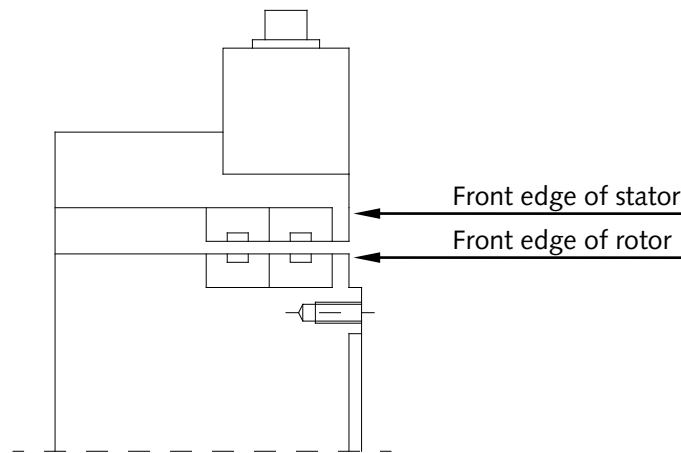

The front edge of the stator and that of the rotor must form one plane.

The axial tolerance is $\pm 0,5 \text{ mm}$.
The center axis of the rotor and stator must be aligned.

The radial tolerance is also $\pm 0,5 \text{ mm}$.

7.1.3 Installation and Removal Instructions for Shrinking Disks

(Type HSD, Factory Stüwe)

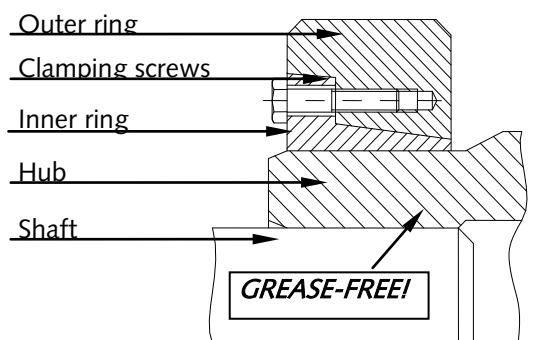

Montage

The shrinking disk are supplied ready to install. They should therefore not be dismantled prior to initial clamping.

1. Note the tightening torque M_A of the shrinking disk (engraved on the outer ring on shrinking disks from Stüwe).

2. Degrease the hub hole and the shaft.

3. Slide the measuring flange together with the clamping set onto the shaft.

Caution:

Never tighten the clamping screws before the sensor is seated on the shaft. For the outer clamping set, a gap of at least 2 mm must be ensured between the shaft end (face) and the inner surface of the measuring flange (immersion depth of shaft = $L_3 - 2$ mm).

4. Position the clamping screws by hand.

5. Tighten every second screw with approx. 10 % of M_A , starting with the upper screw and then continuing with the others. Then check whether the measuring flange can still be turned on the shaft by hand. If it can, tighten the screws further in sequence with approx. 10 % of M_A until the sensor is seated "hand-tight".

6. Check the concentricity (20 ... 40 μ) with a sensor on the centering unit (75 or 110^{H7} or 140^{H7})

7. Locate the highest point, correct the flange position (if a rubber mallet is used, do not strike the transmitter coils or the blue anodized housing parts)

8. Repeat the procedure until the desired concentricity is achieved.

9. Increase the tightening torque of the clamping set screws to 20 % of M_A ; tighten every second screw, then the others. Then tighten all screws in sequence.

10. Check the concentricity and the sensor for firm seating.

11. Increase the tightening torque of the clamping set screws to 30 % of M_A .

12. The sensor is firmly seated. Increase the torque, then tighten the screws consecutively in a circle in several steps up to the maximum tightening torque M_A .

All clamping screws must be tightened until the front ends of the outer and inner ring align.

This enables checking of the correct clamping state to be conducted visually.

Important:

To avoid removal problems due to rusting, spray the gap between the flange hub and the motor shaft with protective wax after mounting (e.g. Klüber Lubrication or Syntheso W)!

Removal

The loosening process is similar to clamping.

1. So that the stored energy of the outer ring can be slowly dissipated via the screws to be loosened during removal, the screws must be loosened evenly and in sequence. Initially only with a quarter turn.

Caution!

The screws may never be completely unscrewed consecutively.

2. Should the outer ring fail to separate from the inner ring by itself after approx. one rotation of all screws, the outer ring can be relaxed using the press-off thread. This is done by screwing several of the neighboring mounting screws into the press-off thread. The outer ring which now separates is supported on the remaining screws. This procedure must be carried out until the outer ring separates by itself.

3. Remove the shaft or pull the hub off the shaft. Rust which may have formed on the shaft in front of the hub must be removed beforehand.

4. Pull the shrinking disk off the hub.

Cleaning and lubricating

Removed shrinking disks need not be dismantled and relubricated before reclamping. The shrinking disk must only be cleaned and the wedge surfaces between the outer ring and the inner ring and the screws must only be relubricated if the shrinking disk is soiled.

A solid lubricant with a high molybdenum sulfide content on an MoS_2 basis with a friction coefficient of $\mu = 0.04$ must be used.

A solid lubricant with a friction coefficient of $\mu = 0.04$ must be used.

Type	Type	Manufacturer
Molykote D-321 R	Gleitlack, Spray	Dow Corning
M Aema-Sol MO 84-K	Pulver-Spray	A.C. Matthes
Molykote G Rapid+	Spray oder Paste	Dow Corning
Aemasol MO 19 P	Spray oder Paste	A.C. Matthes

7.2 Suggestion for Installation

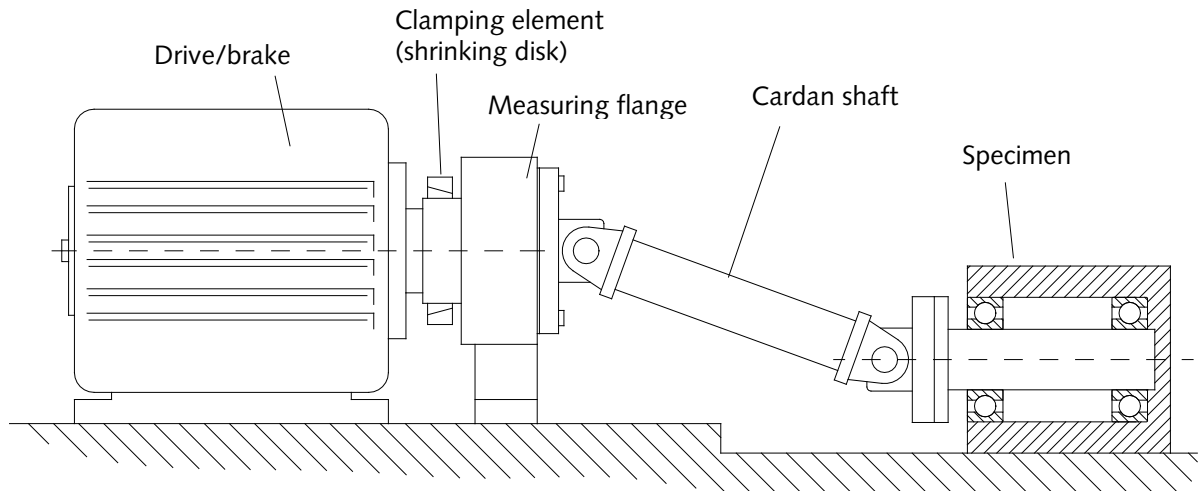
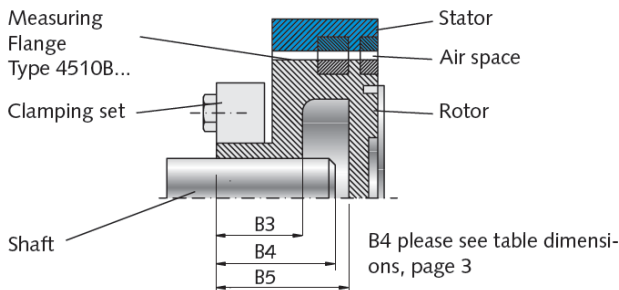

Fig. 11: Suggestion for installation with cardan shaft

7.2.1 Connection of Rotor, Fastening Bolts

Nominal torque M_{nom}	N·m	100	200	500	1 000 1k2	1 000 1k3	2 000	4 000	10 000	20 000
Size		BG 1		BG 2		BG 3			BG 4	BG 5
Thread		M8	M8	M12	M12	M12	M12	M12	M16	M16
Quality class		8.8	8.8	8.8	8.8	8.8	12.9	12.9	12.9	12.9
Min. mounting depth	mm	6	8	13	13	13	16	16	18,5	26
Max. mounting depth	mm	20	20	20	20	20	20	20	45	45
Fastening torque M_{Anz} – Flange	N·m	23	23	80	80	80	137	137	370	370
Fastening torque clamping set	N·m	12	12	35	35	58	58	70	160	295
Balancing class	Q							6,3		
Counterflange flatness	mm							0,01		
Counterflange concentricity	mm							0,02		
Max. offset rotor to stator:										
Axial	mm							±1		
Radial	mm							±1		

Important: Retraction depth has to be strictly observed (Dimension B4)!



8. Electrical and Mechanical Commissioning

8.1 Operating LED

On the upper side of the electronic housing of the torque measuring flange there is a window for the operating light emitting diode (LED). The LED is capable of lighting in three versions:



Switch-on sequence

When the device is switched on (operating voltage is applied) the LED blinks green. After that a short communication with the rotor electronics (LED orange) takes place. Soon after that, the LED is green again. Then, the Torque measuring flange is ready for operation. This sequence takes about 3 seconds.

Communication Torque measuring flange electronics intern or PC ↔ Torque measuring flange

In case the stator electronic communicates with the rotor electronic through the coil pair, the LED lights orange. The LED reacts in the same way, if there is a communication between a master (e.g. PC) and Torque measuring flange through the RS-232C interface.

Torque overload

In case the Torque measuring flange is mechanically overloaded (nominal torque + approx. 10%), the LED lights red. The green condition of the LED is obtained again, once the Torque measuring flange is operated within the nominal torque range.

Errors in the Torque measuring flange electronics

If the Torque measuring flange electronics do not function properly, the LED blinks red. Should this condition persist even after a new start of the Torque measuring flange, send it back to the factory (Kistler).

GREEN	GREEN blinking	ORANGE	RED	RED blinking	Reason
	✓				Power-on condition
✓					Measuring flange ready
		✓			Communication between Stator→Rotor master (PC) ↔ Torque measuring flange
			☹		Torque measuring flange mechanically overloaded
				☹	Torque electronics defective, inform Kistler!

8.2 Adjusting and Calibrating the Torque measuring flange

Zero point and gain can only be set at the supply unit model VA 3600 Type 4704A... or the value processing unit.

Therefore, a TTL- or 3,5 ... 30 V signal can be applied at the control input, to produce an output signal swing corresponding to the nominal torque (see model plate imprint of the electronic cabinet of the Torque measuring flange)

Possible setting routine:

- Let the Torque measuring flange warm up for 10 minutes
- Torque measuring flange must be free from torque, if possible remove the coupling on the measuring side
- Set the zero point in the model VA 3600 Type 4704A... or the value-processing unit
- Operate the control switch at the model VA 3600 Type 4704A... and keep it depressed (or generate a control signal in a different way)
- With the amplifier adjust the output voltage to exactly 10 V
- After that, release the control switch and control the zero point
- If necessary, repeat this operation



A mechanical calibration is more accurate than an electrical adjustment!

8.3 Mechanical Calibration

This requires a calibration device with lever arm and weights for torque generation.

Calibration routine:

- Let the Torque measuring flange warm up for 10 minutes
- Load the Torque measuring flange with nominal torque and then unload it again
- Adjust/document the zero point
- Load the Torque measuring flange with known torque
- Adjust the display to the corresponding torque, and document

Pick-up of a calibration curve

If the Torque measuring flange is used in one direction only, a simple measurement is sufficient.

- Load the Torque measuring flange with nominal torque and unload it again
- Load the Torque measuring flange in 20 % steps until full nominal torque is obtained. After that, unload it in the same manner. Wait at least 30 seconds between the single 20 % steps until stable measured value, and then register the display value

For more complex applications we recommend a comprehensive yearly calibration according to DIN 51309.

8.3.1 Set-up of a Simple Calibration Device

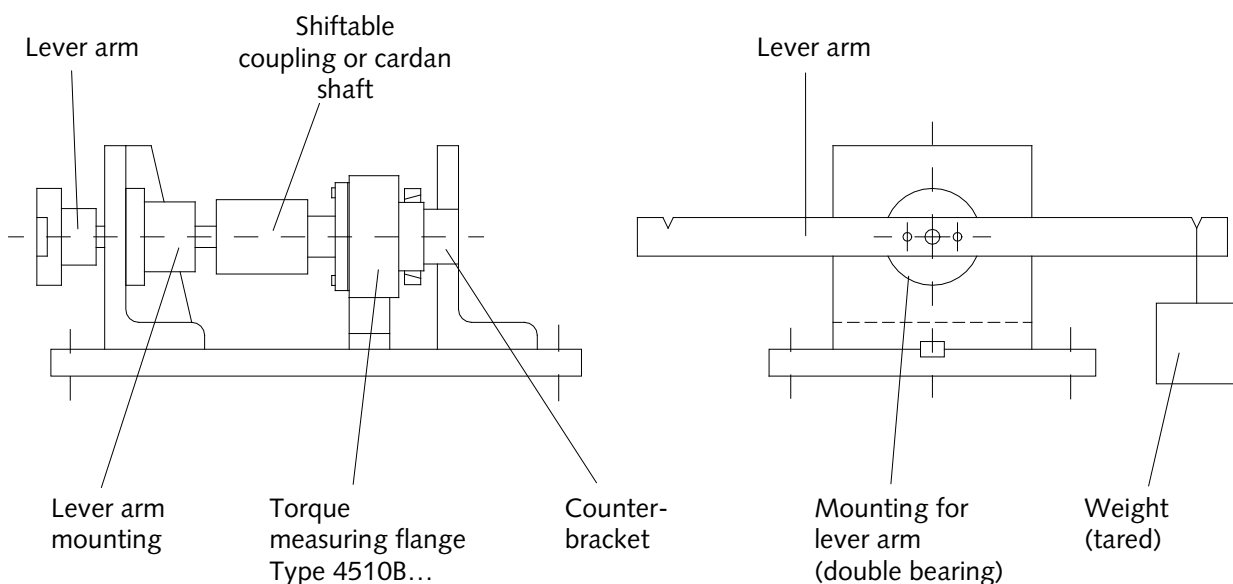
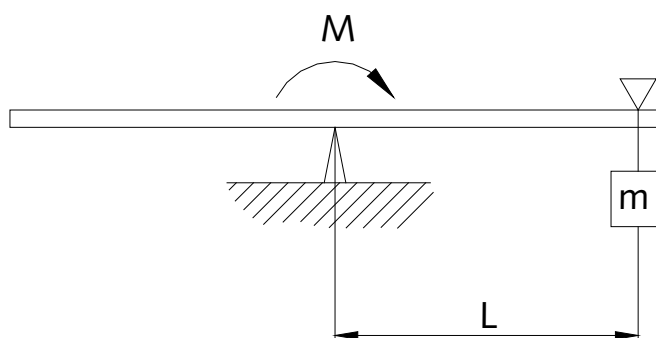

Fig. 12: Set-up of a calibration device

8.3.2 Calculation Example, Lever Arm Length

$$L = \frac{M}{m \cdot g}, \text{ whereby}$$

- M = Torque
 L = Required lever arm length
 m = Required mass
 g = 9,80665 m/s² equals normal case acceleration
 (g depending on location)



Example: $m = 1 \text{ kg}$, $M = 10 \text{ N}\cdot\text{m}$

$$\Rightarrow L_{M=10 \text{ N}\cdot\text{m}} = \frac{M}{m \cdot g} = \frac{10 \text{ N}\cdot\text{m}}{1 \text{ kg} \cdot 9,80665 \frac{\text{m}}{\text{s}^2}} \approx 1,0197 \text{ m}$$

9. Making Torque Measurements

9.1 Switch on the Torque measuring flange

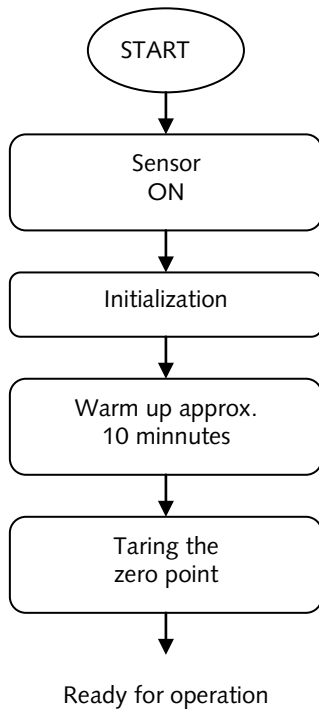

When the device is switched on then the following steps are recommended to reach optimal measuring accuracy:

After the device is switched on the LED is blinking green then orange to take calibration values, after that the LED is green again. This sequence takes about 3 seconds.

To tare the zero point is recommended:

- after warm up
- after integrating the torque sensor in the mechanical equipment (taring the mechanic rest torque)

9.2 Qualities After Switching Measuring Range

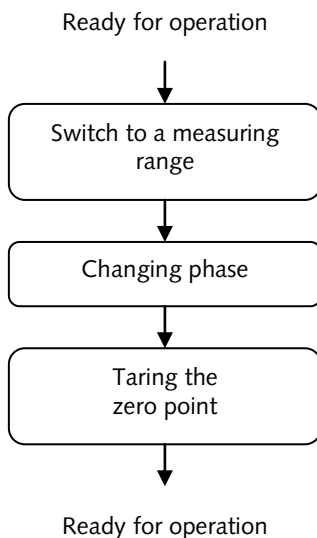

When the measurement range is switched (1:1 → 1:10 or 1:10 → 1:1) then the following steps are recommended:

The measuring range can be switched through the digital input or the RS-232C interface of the 7-pole panel plug.

Within the changing phase new calibration values are loaded. The LED lights orange, after 1,5 seconds green again.

The zero points of both measuring ranges can be different. A new taring of the new zero point is recommended.

10. RS-232C Communication

Torque-equivalent values can be transmitted through the RS-232C interface. The following illustrates the sensor model regarding the RS-232C command structure of the Torque measuring flange Type 4510B... .

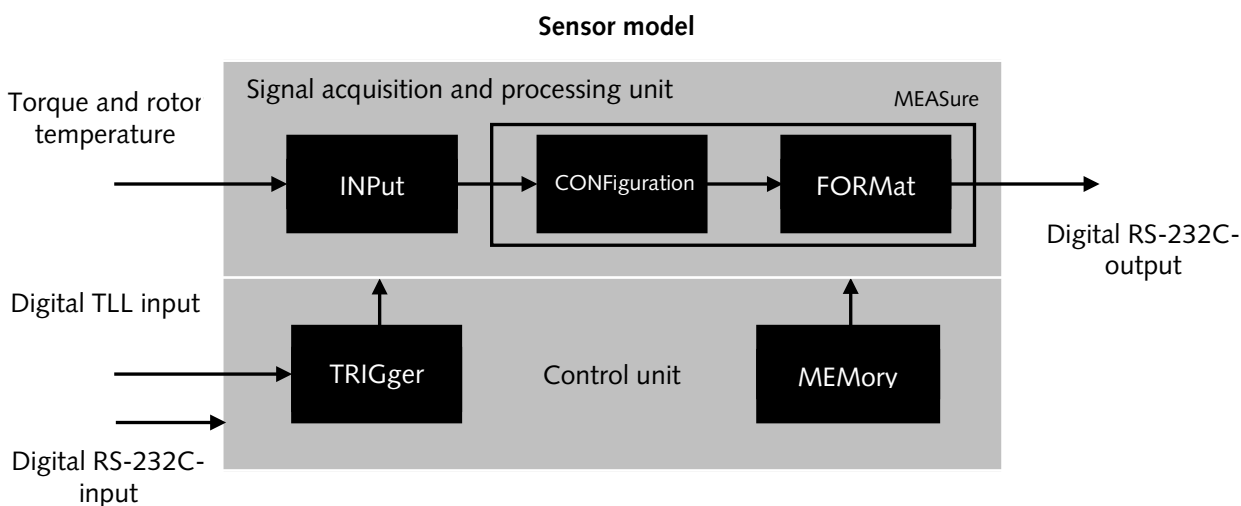

Fig. 13: Sensor model regarding the RS-232C command structure

Signal acquisition and processing unit

The Torque measuring flange continuously measures the torque value, and the rotor temperature in cycles. In the *INPut* function block calibration settings and primarily the range-selection are performed. Furthermore, the control signal can be initiated.

In the *CONFiguration*- and *FORMat* function block, configurations regarding value transmission are carried out. Both function blocks together make the *MEASure*-function block.

Control unit

In the *TRIGger*-function block it is defined which action the Torque measuring flange should perform in case of an external triggering (digital, TTL-signal). In the external trigger process either the control signal or a value transmission is activated. All calibration and user data are saved in the *MEMory* function block with power failure protection.

10.1 Interface Parameters

The RS-232C interface of the Torque measuring flange applies the following settings:

- Transmission rate (baudrate) 57 600 bits/second
- 8 Data bits
- 1 Stop bit
- No parity

10.1.1 Conventions and Syntax

The Torque measuring flange responds through the RS-232C interface only if it receives a command from the master (e.g. PC) (PC = master, Torque measuring flange = slave). The Torque measuring flange always responds even if the master transmits only configurations. The operation LED of the Torque measuring flange lights orange (green and red together) if there is a communication.

The master transmits only ASCII commands. These commands must always be followed by <CR> (*carriage return*) and <LF> (*line feed*) as termination character. The Torque measuring flange as well transmits the same termination to the master.

Example:

Master (e.g. PC): MEAS:TORQ?<CR><LF>
(value inquiry)

Response of the
Torque measuring flange: 32789<CR><LF>
(torque-equivalent value)

Capital and small letters are disregarded, plus the command interpreter of the Torque measuring flange ignores possible blank characters placed in front, and blank characters within the command.

Example:

typical	MEAS:TORQ?<CR><LF>
identical with	MEAS :torq ? <CR><LF>
identical with	MeaS :Torq?<CR><LF>



The termination is always effected with the characters <CR><LF> .

A command for an inquiry ends with "?" (e.g. MEAS:TORQ?<CR><LF>).

When a configuration transmission was successful, "0" is returned as success message (e.g.. PC: CONF:TEMP<CR><LF> → Sensor: 0<CR><LF>).

If a command was not accepted for different reasons, the Torque measuring flange returns a negative error value.

The color of the LED of the Torque measuring flange changes from green to orange during communication through the RS-232C interface.

In the following the termination characters (<CR><LF>) are left out to allow more transparency.

10.1.2 Error Messages

The Torque measuring flange transmits a negative error value, if a command was not accepted for different reasons (see the following table):

Error value	Description of error	Remedy
-100	Command was not understood	Check command syntax (e.g. <i>MEAS?</i> instead of <i>MEASure?</i>) Send command again, sensor might be busy
-101	"?" was not added to an inquiry	Ad "?" to an inquiry
-104	Calculation steps resulted in overflow	Check calculation variables (in-house utilization)
-105	Error when non-volatile memory area was accessed	Redefine memory area, inform Kistler
-106	Access on protected memory area	Eliminate storage protection (in-house utilization)
-107	Continuous transmission between rotor- and stator electronics active	Temporarily disconnect the continuous transmission (in-house utilization)
-108	Transmitted character chain too long	Shorten the character chain (in-house utilization)
-109	Transmitted numeric value invalid	Check numeric value (in-house utilization)
-110	Impossible to switch to the other measuring range	Calibrate the sensor in the other measuring range (send to Kistler)



The error value -110 can only be sent with firmware version V2.00 or newer of the stator!

10.1.3 Measuring Rates, Reaction Times

Depending on the configuration in the *CONFiguration*- and *FORMat*-function blocks different transmission rates are affected through the RS-232C interface (value queries per second). Please refer to the commands:

- CONF** (value query – configuration for the MEAS-command)
- FORM** (define output format)

In each value query a torque equivalent value is transmitted. Like that, rapid torque modifications can be reproduced as digital quantities.

It helps to use the short command *M?* (instead of *MEAS?* or *MEAS:TORQ?*), to transmit torque equivalent values with high transmission rate. This reduces the reaction time of the command interpreter in the Torque measuring flange.

The following transmission rates apply for utilization of the short command *M?* or extern triggering via digital signal (control input).

Trigger mode	Output format FORM:DATA:<output format>	Meas. Period practicable in ms	Measurements per second practicable
Command <i>M?</i>	ASC	3	333
Command <i>M?</i>	HEX	2,5	400
Command <i>M?</i>	BIN	2	500
Extern digital	ASC	2,5	400
Extern digital	HEX	2	500
Extern digital	BIN	1	1000

The higher the scanning rate, the more values can be taken from a measuring sequence. The interpretation capability of the resulting measuring curve increases accordingly.

10.1.4 Requesting Torque Values Through RS-232C Command

Torque values can be requested with

MEAS:TORQ?

MEAS? (if previously configured with *CONF:TORQ*)
M?

After each inquiry only one torque-equivalent value is transmitted. For a later interpretation of the measuring curve the assignment of the positive nominal torque value and the digital output value is critical. The following assignments result:

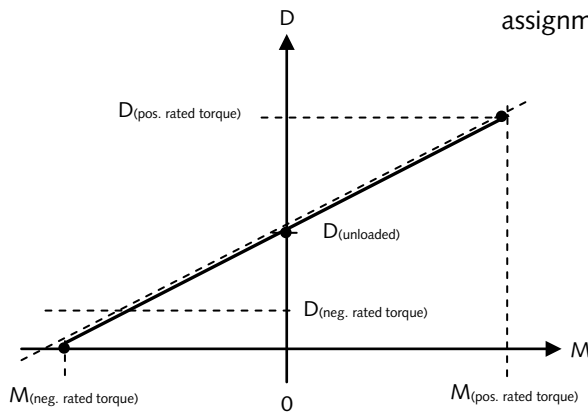

The following correlation between torque *M* and the torque-equivalent value *D* results from the graphic:

Torque		Digital data value
$M_{(pos. \text{ rated torque})}$	\Rightarrow	$D_{(pos. \text{ rated torque})}$
0	\Rightarrow	$D_{(unloaded)}$
$M_{(neg. \text{ rated torque})}$	\Rightarrow	$D_{(neg. \text{ rated torque})}$

The torque equivalent value *D* ranges between 0 ... 65 535, whereby it can only accept positive values. Since offsets may occur during sensor assembly due to mechanic stresses, we recommend only evaluating the digital output swing

$$D_{Hub} = D_{(pos. \text{ rated torque})} - D_{(unloaded)}$$

The digital output swing at nominal torque is indicated in your calibration protocol or in the memory area of the Torque measuring flange with the command **MEM:DATA:MAGN?** (**MEM:EXT:DATA:MAGN?** for the extended measuring range).

The nominal range of the Torque measuring flange can additionally be determined with the command **MEM:RANG?** (**MEM:EXT:RANG?** for the extended measuring range).

Example:

- PC command \rightarrow response of the torque measuring flange
- MEM:DATA:MAGN?** \rightarrow **26658** (digital output swing)
- MEM:RANG?** \rightarrow **500** (rated torque for 1:1 measuring range in N·m)

Consequently:

In 1:1 measuring range at 500 N·m a digital output swing of 26658 results, which is added to the digital offset value in unloaded condition.

10.1.5 Requesting Torque Measuring Values via External Triggering

The **external triggering** with a digital signal can only be executed, if after start-up the Torque measuring flange has been initialized one time with the TRIGger command. Please refer to the command:

TRIG (specify trigger mode)

At each trigger operation by the master (e.g. PC or SPS) a torque-equivalent value is transmitted from the Torque measuring flange.

For that purpose use the **external digital control input (PIN K of the 12 pin panel plug)**.

Assignments between logic conditions and voltage level are explained in the chapter "plug assignment, connection diagram".

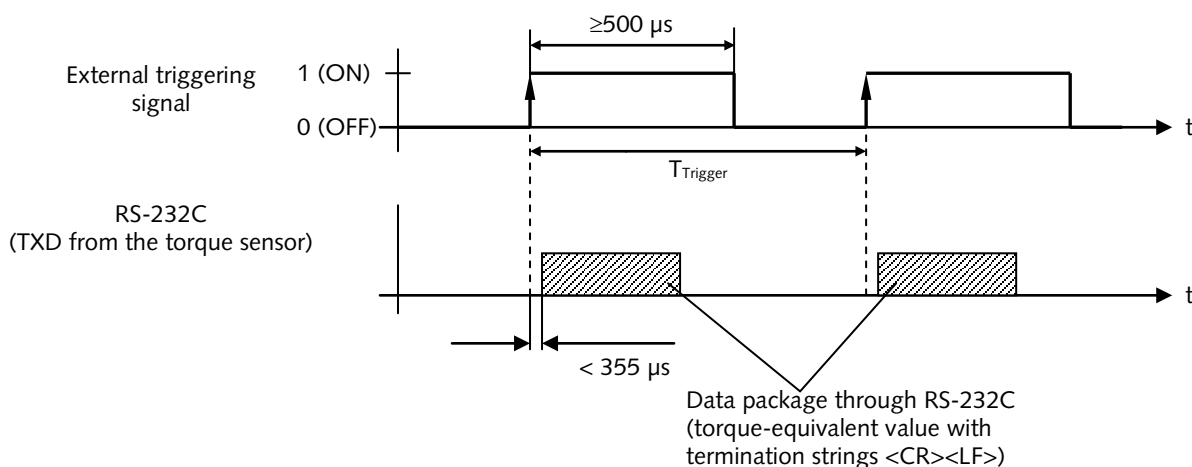

Fig. 14: Connecting diagram



The period $T_{Trigger}$ (measuring period) should never be shorter than indicated in chapter "measuring rates, reaction times", to guarantee a safe RS-232C transmission from the Torque measuring flange!



During the cyclic triggering the Torque measuring flange does not accept any RS-232C commands from the master (e.g. PC). In order to reestablish communication cyclic triggering must first be completed.

10.2 Typical Measuring Sequence

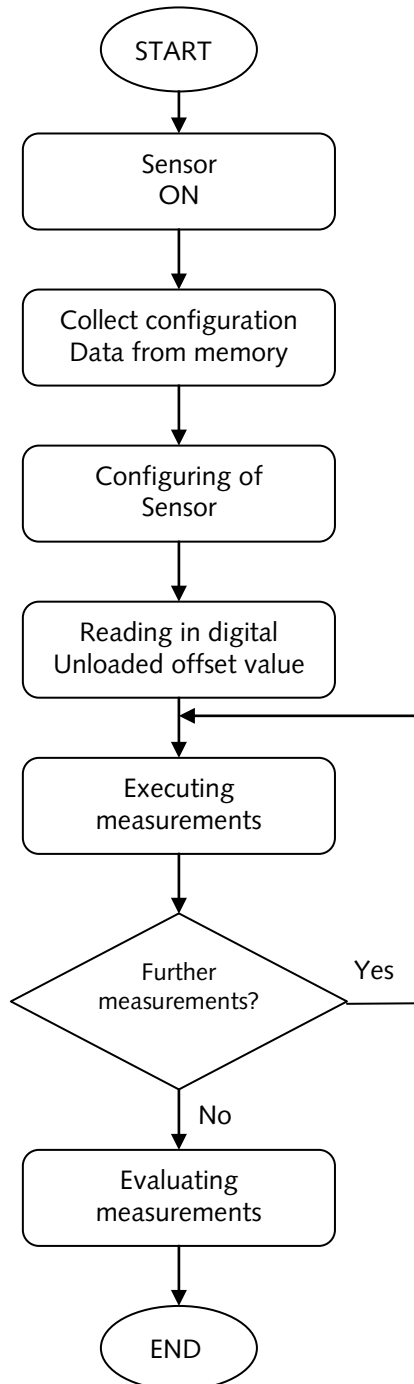

After switching on the torque sensor allow the electronics of the torque sensor approx. 10 min to warm up.

If desired all user data can be uploaded from the memory of the torque sensor for sensor identification. **Important:** digital output swing (set point)

The measuring range (if the sensor is calibrated in the extended measuring range), the trigger mode and output format can be defined here.

The digital offset value (when unloaded = 0 N·m) is interesting if relative values are used for measurement (recommended: digital taring at the evaluation system).

Use a high measuring rate to measure rapid mechanical changes.

The rotor temperature (*MEAS:TEMP?*) can be measured in cycles, e.g. every 500 torque values 1 temperature value (since a temperature change of the rotor is extremely slower).

With the help of the digital output swing (set point) assignments between the torque equivalent values and the actual torque values can be carried out.

10.3 Configuration Commands

INPut

The *INPut*-command group mainly influences the rotor electronics. The control signal can be activated or deactivated in this group. The gain changeover (selection between 1:1 and 1:10 range) is performed here as well.

CONFIguration and FORMat

In these command groups it is specified which value types and output formats should be defined.

TRIGger

With the *TRIGger*-command group the Torque measuring flange reaction can be specified, in case a signal change at the control input is carried out (Activation of control or torque-equivalent value transmission through RS-232C interface).

MEMory

In this command group all calibration and user dates are filed.

10.3.1 Range Selection

INP:GAIN:MULT:<function>

Parameter <function> = ON (1:10 measuring range)
 OFF (1:1 measuring range)

Inquiry INP:GAIN:MULT?

Description

This command is used for a range selection. With *INP:GAIN:MULT:ON* the 1:10 value range and with *INP:GAIN:MULT:OFF* the standard range (1:1 range) are defined.

Standard INP:GAIN:MULT:OFF (1:1 measuring range)

Notes

Value selection may only be applied, if the torque measuring flange has in fact been calibrated in the 1:10 range.

Examples

PC command → response of the torque measuring flange

INP:GAIN:MULT:ON → 0 (measuring range 1:10)

INP:GAIN:MULT? → ON

INP:GAIN:MULT:OFF → 0 (measuring range 1:1)

INP:GAIN:MULT? → OFF

10.3.2 Control Signal (Calibration Signal) On or Off

INP:CONT:<function>

Parameter <function> = ON Control signal
switched on
OFF Control signal
switched off
(normal operation)

Query INP:CONT:STAT?

Description

With this command the control signal (colloquial: calibration signal) can be switched on or off, whereby the signal path between rotor- and stator electronics is checked. With **INP:CONT:ON** the control signal is activated, whereby the output signal value (output voltage / output frequency or digital output value) changes to nominal value. The normal operation is obtained with **INP:CONT:OFF** and the control signal switched off. The operating condition can be queried with **INP:CONT:STAT?**

Standard INP:CONT:OFF → Control signal switched off
(normal operation)

Notes

If the control signal is switched on with **INP:CONT:ON** it remains activated until the command **INP:CONT:OFF** is transmitted or the Torque measuring flange switched off and on. The control signal cannot be switched off by the extern triggering (permanent condition 0), if the control signal has previously been activated via **INP:CONT:ON**.

Examples

I			
NP	command	→	response of the torque measuring flange
P			
:	INP:CONT:ON	→ 0	(control signal on)
G	INP:CONT:STAT?	→ ON	
O	<i>Trigger: 0-Zustand</i>	→	<no answer>
N			(control signal remains active)
T			
:	INP:CONT:OFF	→ 0	(control signal off)
s	INP:CONT:STAT?	→ OFF	
T			
A			
T			

10.3.3 Value Query – Configuration for the MEAS Command

CONF:<function>

Parameter → TORQ (torque value)
 <function> = TEMP (rotor temperature)
 Inquiry CONF?

Description

With this command the type of value query is specified. With **CONF:TORQ** and then with **MEAS?** a torque equivalent value can be evaluated. Through **CONF:TEMP** and then **MEAS?** the rotor temperature is transmitted. The defined configuration can be evaluated with **CONF?**.

Note

The short command **M?** transmits only one torque equivalent value.

Standard: **CONF:TORQ**

Examples

PC-Kommando	→		response of the torque sensor
CONF:TORQ	→	0	(configuration equivalent value)
CONF?	→	TORQ	
FORM:DATA:ASC	→	0	(decimal output format)
MEAS?	→	32765	(torque-equivalent value)
MEAS?	→	32767	
CONF:TEMP	→	0	(configuration Rotor temperature)
CONF?	→	TEMP	
MEAS?	→	26	(rotor temperature in °C)

10.3.4 Defining the Output Format

FORM:DATA:<function>

Parameter <function>	→	=ASC	(decimal output format)
	→	HEX	(hexadecimal output format)
	→	BIN	(binary output format)

Inquiry FORM:DATA?

Description

The output format through the RS-232C interface regarding the torque measuring value can be influenced by this command. Through **FORM:DATA:ASC** an ASCII-format is defined in decimal form. Through **MEAS?** (or **MEAS:TORQ?** or **M?**) a torque equivalent value (0 ... 65535) is transmitted. With **FORM:DATA:HEX** a hexadecimal output format is defined (0000 ... FFFF).

A binary output format (2 Bytes: <HBYTE><LBYTE>, whereby

$(H/L)BYTE \in \{00000000_2, \dots, 11111111_2\}$),
is set with **FORM:DATA:BIN**.

Note

Please consider that user bytes may occur in the binary output format, which may equal the characters of the termination! Therefore evaluate only the last 2 of the 4 bytes <HBYTE><LBYTE><CR><LF> as termination!

Standard FORM:DATA:ASC

Examples

PC-Kommando	→		response of the torque measuring flange
CONF:TORQ	→	0	(configuration torque value)
FORM:DATA:ASC	→	0	(decimal output format)
FORM:DATA?	→	ASC	
M?	→	46238	
CONF:TORQ	→	0	
FORM:DATA:HEX	→	0	(hexadecimal output format)
FORM:DATA?	→	HEX	
M?	→	B49C	(= 46236 ₁₀)
CONF:TORQ	→	0	
FORM:DATA:BIN	→	0	(binary data format)
FORM:DATA?	→	BIN	
M?	→	<10110100><10011111>	(= 46239 ₁₀)

10.3.5 Determining the Trigger Mode

TRIG:MODE:<function>

Parameter <function> =

CONT

(external trigger activated/deactivated control signal)

MEAS

(external trigger activates value transmission through RS-232C)

Inquiry TRIG:MODE?

Description

This command specifies which action the Torque measuring flange should perform at extern triggering (digital TTL-signal). With **TRIG:MODE:CONT** the control signal is activated or deactivated at extern triggering (permanent logic condition). Through **TRIG:MODE:MEAS** the Torque measuring flange transmits a torque equivalent value at extern triggering. One value is transmitted per trigger operation (logic 0-1-change of state at PIN K of the 12 pin panel plug).



In order to ensure correct RS-232C transmission in a triggered value transmission you should never trigger any faster than indicated in the chapter "measuring rates, reaction times"!

Standard TRIG:MODE:CONT

Examples

PC-Kommando	→	response of the torque sensor
TRIG:MODE:CONT	→ 0	(control signal at external triggerung)
TRIG:MODE?	→ CONT	
<i>Trigger: 1-Zustand</i>	→ <no response>	control signal on)
<i>Trigger: 0-Zustand</i>	→ <no response>	(control signal off , normal operation)
FORM:DATA:ASC	→ 0	(decimal output format)
TRIG:MODE:MEAS	→ 0	(value transmission at external triggering)
TRIG:MODE?	→ MEAS	
<i>Trigger: 0-1-Wechsel</i>	→ 43788	(torque-equivalent value)
<i>Trigger: 0-1-Wechsel</i>	→ 43956	
<i>Trigger: 0-1-Wechsel</i>	→ 44228	

10.3.6 Determining Sensor Data

*IDN? IDN?	Torque measuring flange identification
---------------	--

MEM:<function>?

Parameter <function> =

General Torque measuring flange data	
TYPE	Torque measuring flange type
SER	serial number
MDAT	date of manufacture
CDAT	calibration date
CWOR	calibration worker
CUST	customer name
TMIN	minimal operation temperature in ° C
TMAX	maximal operation temperature in ° C
SOUR	output mode(s)
SPE:MAX	maximal speed in revolution per minute (min ⁻¹)
SPE:IMP	pulses per revolution

Data for the 1:1 – measuring range	
RANG	measuring range in N·m
LINE	accuracy of linearity in % (full scale 1:1 – range)
OUTP:VOLT:MAGN	output voltage swing at rated torque in V
OUTP:VOLT:CONT	output voltage swing at control in V
OUTP:FREQ:MAGN	output frequency swing at rated torque in kHz
OUTP:FREQ:CONT	output frequency swing at control in kHz
DATA:MAGN	digital torque equivalent output swing in digits

	Data for the 1:10 – measuring range
EXT:VALI	query, if sensor is calibrated in the 1:10 – range
EXT:RANG	measuring range in N·m
EXT:LINE	accuracy of linearity in % (full scale 1:10 – range)
EXT:OUTP:VOLT:MAGN	output voltage swing at rated torque in V
EXT:OUTP:VOLT:CONT	output voltage swing at control in V
EXT:OUTP:FREQ:MAGN	output frequency swing at rated torque in kHz
EXT:OUTP:FREQ:CONT	output frequency swing at control in kHz
EXT:DATA:MAGN	digital torque equivalent output swing in digits

Description

With this command all relevant data from the non-volatile memory can be determined. This may be used for sensor identification.

Applications:

- automatic sensor identification
- Assignment of torque-equivalent digital values from the RS-232C interface with the respective measuring range

Example 1: device identification

A Torque measuring flange Type 4510B... from Kistler includes a device identification string chain with following construction:

Kistler Lorch GmbH_4510BStator_YYYY-MM-DD_Vx.xx_4510BRotor_YYYY-MM-DD_Vx.xx

a) b) c)

- **device identification header**
The header *Kistler Lorch GmbH* refers to a Kistler device
- **firmware version of the stator electronic circuit**
The string chain *4510BStator_YYYY-MM-DD_Vx.xx* refers to the date and the version number of the micro computer firmware of the stator electronic circuit
- **firmware version of the rotating electronic unit**
The string chain *4510BRotor_YYYY-MM-DD_Vx.xx* refers to the date and the version number of the micro computer firmware from the rotary electronic circuit

PC command → response of the torque measuring flange

*IDN?
IDN?



Kistler Lorch GmbH_4510BStator_2003-04-18_V2.00_4510BRotor_2002-11-20_V1.6

Example 2: Determining of general data

The general data of a multi-calibrated torque measuring flange Type 4510B... with a ± 10 V voltage output at ± 100 N·m nominal torque should be transmitted via the RS-232C interface:

PC command	→	response of the torque sensor
MEM:TYPE?	→	4510B100A0B10
MEM:SER?	→	109602
MEM:MDAT?	→	2014
MEM:CDAT?	→	2014-01-23
MEM:RANG?	→	100
MEM:SPE:MAX?	→	12 000
MEM:SPE:IMP?	→	1x60

Example 3:

Determining measuring data for the 1:1 measuring range

MEM:OUTP:VOLT:MAGN?	→	10
MEM:OUTP:VOLT:CONT?	→	10
MEM:OUTP:FREQ:MAGN?	→	0.000
(because of voltage output only)		
MEM:OUTP:FREQ:CONT?	→	0.000
(because of voltage output only)		

Example 4:

Determining measuring data for the 1:10 measuring range

MEM:EXT:OUTP:VOLT:MAGN?	→	10
MEM:EXT:OUTP:VOLT:CONT?	→	10
MEM:EXT:OUTP:FREQ:MAGN?	→	0.000
(because of voltage output only)		
MEM:EXT:OUTP:FREQ:CONT?	→	0.000
(because of voltage output only)		

Example 5:

Determining the notes of the type designation plate

A multi-calibrated torque measuring flange is equipped with two type designation plates. These notes can be transmitted via the RS-232C interface:

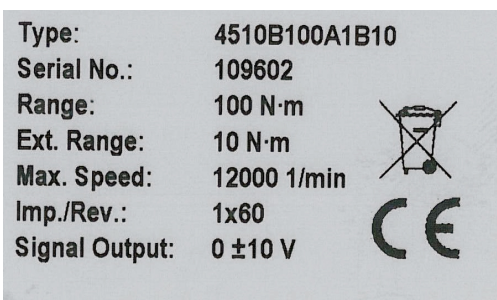

10.4 Measuring Commands

10.4.1 Transmitting Torque and Temperature Measuring Quantity

MEAS<function>

Parameter <function> = ?

(Value transmission according to

CONF-setting) :TORQ? (Torque value)

:TEMP? (Rotor temp. value)

Description

With this command the torque measuring flange can transmit a torque equivalent value or the rotor temperature through the RS-232C interface. With *MEAS?* The torque or temperature measuring quantity is transmitted depending on CONF-setting. The Torque measuring flange transmits a torque equivalent value through *MEAS:TORQ?* and the rotor temperature in C° with *MEAS:TEMP?*.

Note

Instead of *MEAS:TORQ?* or *MEAS?* (previously defined with *CONF:TORQ*) the short command *M?* can be used as well. This increases the reaction speed of the command interpreter in the torque measuring flange for transmission of a torque equivalent value.

Examples

PC command	→		response of the torque sensor
FORM:DATA:ASC	→	0	(decimal output format)
MEAS:TORQ?	→	32658	(torque-equivalent value)
MEAS:TORQ?	→	32102	
MEAS:TORQ?	→	31856	
MEAS:TEMP?	→	32	(rotor temperature value)
FORM:DATA:ASC	→	0	(decimal output format)
CONF:TORQ	→	0	(configuration torque)
MEAS?	→	45327	(torque-equivalent value)
MEAS?	→	46201	
MEAS?	→	46128	

FORM:DATA:HEX	→	0	(decimal output format)
CONF:TORQ	→	0	(Configuration torque)
M?	→	D0AE	(torque-equivalent value)
M?	→	D205	
M?	→	D275	
CONF:TEMP	→	0	(Configuration rotor temperature)
MEAS?	→	31	(Rotor temperature in °C)
MEAS:TEMP?	→	31	(Rotor temperature in °C)

11. Maintenance

- Torque measuring flanges of the Type 4510B... series are nearly maintenance-free
- Precision applications: recalibrate the Torque measuring flange once a year (Calibration in the factory or with adequate calibration device)
- Control correct position of cable plugs monthly.
- Check cables for damages monthly

12. Repairing the Measuring Shaft

- Zero point offset lower than approx 2 %
Readjust the zero point
- Zero point offset between approx 2 % and 5 %:
Torque measuring flange was overloaded
The zero point can once be readjusted at the amplifier
- Zero offset higher than approx 5 % or several times between 2 % and 5 %
Return the Torque measuring flange to the factory for examination
- Transducer has hysteresis between torque ccw and cw.
Transducer was overloaded.
New torsion shaft required. Return the transducer to the factory

13. Technical Data

13.1 Mechanical Basic Data

Type 4510B...		100	200	500	1k2	1k3	2k0	4k0	10k	20k	
Rated torque	M_{nom}	N·m	100	200	500	1 000	1 000	2 000	4 000	10 000	20 000
Measuring range		N·m	100	200	500	1 000	1 000	2 000	4 000	10 000	20 000
Max. load clamping set		N·m	570	570	2 400	2 400	4 060	4 060	10 400	26 500	44 000
Limiting torque	M_{op}	N·m	265	400	1 300	1 800	1 800	3 000	7 500	16 000	30 000
Rupture torque	M_{rupt}	N·m	>400	>800	>2 000	>4 000	>4 000	>8 000	>16 000	>40 000	>80 000
Alternating torque	M_{dyn}	N·m	100	200	500	1 000	1 000	2 000	4 000	10 000	20 000
Nominal speed	n_{nom}	1/min	12 000	12 000	9 000	9 000	9 000	9 000	9 000	4 000	4 000
Torsional rigidity	C_T	kN·m/rad	125	290	417	1 316	1 587	2 597	5 333	21 277	27 397
Rotation angle at M_{nom}	φ	°	0,046	0,04	0,069	0,044	0,036	0,044	0,043	0,027	0,042
Max. bending torque	M_b	N·m	1 600	1 600	1 700	1 700	5 000	5 000	8 500	18 000	18 000
Longitudinal force	F_A	kN	22	20	54	78	116	84	212	379	475
Max. radial force	F_Q	kN	3	3	8	8	12	15	20	30	40
Rotor weight	m_{rotor}	kg	4,4	4,4	7,7	7,8	10	10	12	36	41,8
Stator weight	m_{stator}	kg	3,6	3,6	4,4	4,4	4,4	4,4	4,4	2,3	2,8
Moment of inertia (rotor)	j_{rotor}	kg·m ² ·10 ⁻³	11,4	11,5	31	31,2	39,3	39,4	55,3	374	495
Partial mass of the rotor (measurement side)	$m_{rotor-M}$	kg	2,2	2,2	2,9	2,9	3,7	3,7	3,8	7,4	7,4
Partial moment of inertia of the rotor (measurement side)	$j_{rotor-M}$	kg·m ² ·10 ⁻³	8,2	8,2	20,1	20,2	21,8	21,8	21,9	90,8	90,8
Balancing class	Q		6,3								
Housing material			Hard anodized aluminum								
Protection class			IP54								

13.2 General Electrical Specifications

General Electrical Specifications

Output signal option B1	VDC	±0 ... 10
at M_{nom} (rated value)	VDC	10
Output signal option B2	kHz	100±40
at M_{nom} (rated value)	kHz	140 (40)
Load resistance	kΩ	>10
Limit frequency -3 dB	kHz	1
100 % control input	VDC	"On" 3,5 ... 30 "Off" 0 ... 2
Control signal	% FSO	100±0,1
Supply voltage	VDC	11 ... 30
Power consumption	W	<5

Electrical Measuring Data

Zero point stability (for 24 h)	% FSO	0,03
Reference temperature	°C	22 ±2
Operating temperature range (Rated temperature range)	°C	10 ... 60
Service temperature range	°C	0 ... 70
Storage temperature range	°C	-25 ... 80

13.3 Electrical Measuring Data – Standard Measuring Range 1:1

Rated torque	N·m	100 ... 4 000	10 000 ... 20 000
Accuracy class		0,2	0,2
Linearity error including hysteresis	%FSO	<±0,1	<±0,2
Temp. influence on the zero point	%FSO/10 °C	<±0,2	<±0,2
Temp. influence on the nominal value	%FSO/10 °C	<±0,2	<±0,2

13.4 Electrical Measuring Data – Extended Measuring Range 1:5, 1:10

Rated torque	N·m	100 ... 4 000
Accuracy class		0,4
Linearity error including hysteresis	%FSO	<±0,2
Temp. influence on the zero point	%FSO/10 °C	<±0,4
Temp. influence on the nominal value	%FSO/10 °C	<±0,4

Electrical Measuring Data – Speed

Pulses/revolution		1x60
Output signal	V	5 (TTL)

14. Dimensions

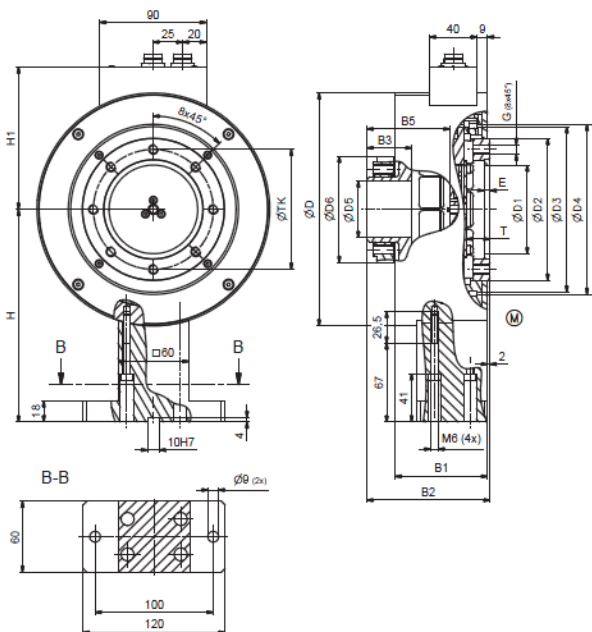

Fig. 1: Type 4510B... size 1 and 3,
100 N-m, 200 N-m, 1 000 N-m, 2 000 N-m, 4 000 N-m

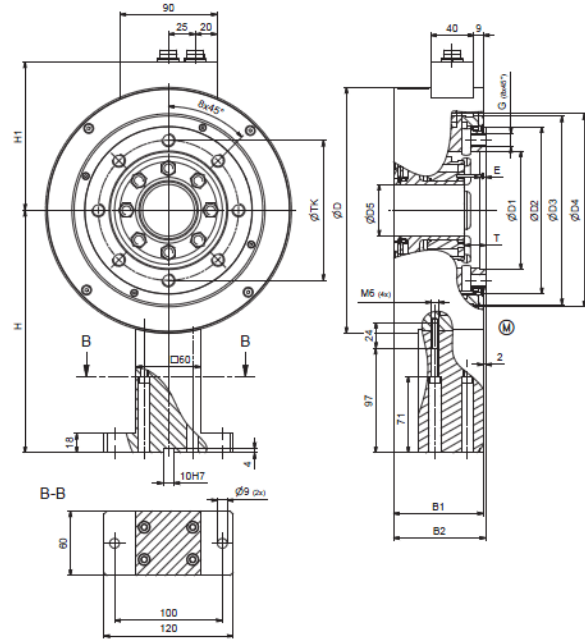

Fig. 2: Type 4510B... size 2,
500 N-m and 1 000 N-m

(M) = Measuring end

Dimensions in mm

Size	Measuring range N·m	øD	øD1 _{H7}	øD2	øD3	øD4	øD5 _{G5}	øD6	B1	B2	B3	B4 ²⁾	B5	T	E	TKø	G	H	H1
1	100	197	75	120	140	144	48	90	78	104	38	68	70	20	5	101,5	M8	180	120,5
1	200	197	75	120	140	144	48	90	78	104	38	68	70	20	5	101,5	M8	180	120,5
2	500	228	110	155	175	179	48	-	83,5	85,5	65	-	-	20	5	130	M12	225	137,7
2	1 000	228	110	155	175	179	48	-	83,5	85,5	65	-	-	20	5	130	M12	225	137,7
3	1 000	228	110	155	175	179	65	141	83,5	123	57	86	88	19	5	130	M12	225	137,7
3	2 000	228	110	155	175	179	65	141	83,5	123	57	86	88	19	5	130	M12	225	137,7
3	4 000	228	110	155	175	179	80	170	83,5	132	64	93	95	19	5	130	M12	225	137,7

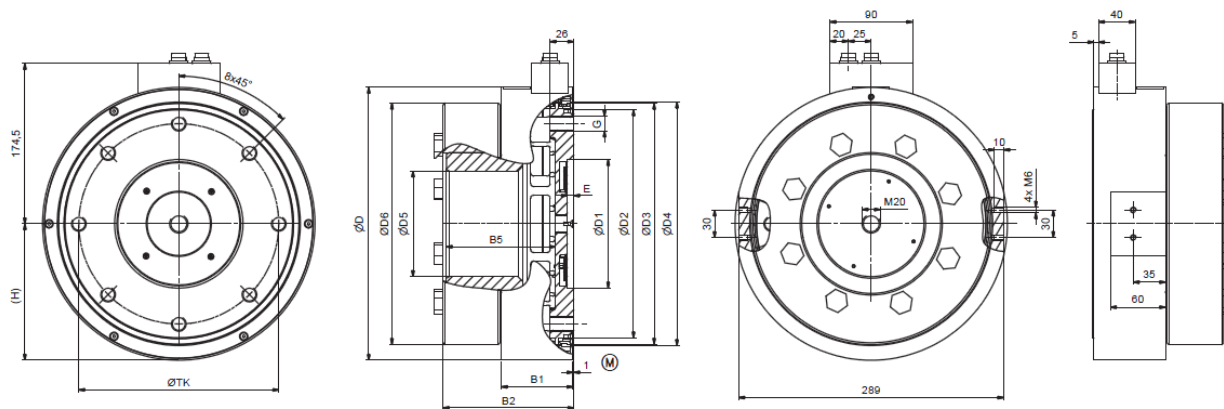

Fig. 3: Type 4510B... size 4, 10k

(M) = Measuring end

Dimensions in mm

Size	Measuring range N·m	ØD	ØD1 _{H7}	ØD2	ØD3	ØD4	ØD5 _{G5}	ØD6 _{g6}	B1	B2	B5	E	TKØ	G	H
4	10 000	297	140	250	262	165	115	263	79	142,5	119	7	218	M16	148,5

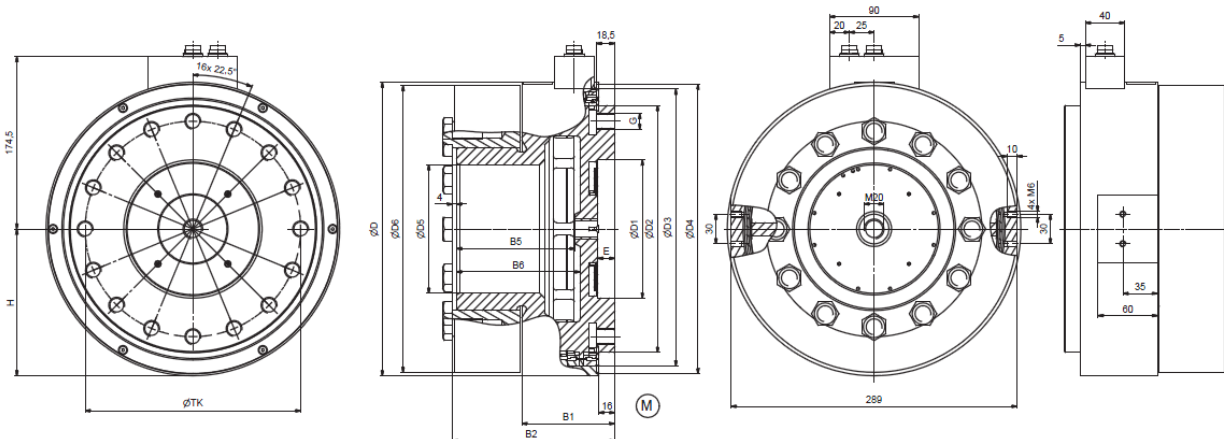

Fig. 4: Type 4510B... size 5, 20k

(M) = Measuring end

Dimensions in mm

Size	Measuring range N·m	ØD	ØD1 _{H7}	ØD2	ØD3	ØD4	ØD5 _{G5}	ØD6	B1	B2	B4 ²⁾	B5	B6	E	TKØ	G	H
5	20 000	297	140	250	280	293	130	290	94	164	118	120	125	17	218	M16	148,5

15. Ordering Key and Accessories

Included Accessories

- None

Optional Accessories

- | | |
|--|----------------------------|
| • Connection cable, length 5 m | Type/Art. No.
KSM007203 |
| • Connection cable, length 5 m,
12 pin – open ends | KSM124970-5 |
| • Connection cable, length 5 m,
7 pin – open ends | KSM219710-5 |
| • Connection cable, length 2,5 m,
12 pin – CoMo Torque | KSM186420-2,5 |
| • Female connector 7 pin (plug C) | KSM000517 |
| • Female connector 8 pin (plug D) | KSM013136 |
| • ControlMonitor CoMo Torque
Evaluation instrument for torque sensors | 4700B... |
| • Adapter flanges | 2300A... |
| • Torsion proof multi-disk couplings | 2300A... |
| • SensorTool | 4706A |

Our torque calibration service lab DKD-K-37701 offers traceable recalibration of any brands.

For further information of cable and connector see data sheet 000-615.

Ordering Key

Measuring Ranges in N-m

100	Size 1	100
200	Size 1	200
500	Size 2	500
1 000	Size 2	1k2
1 000	Size 3	1k3
2 000	Size 3	2k0
4 000	Size 3	4k0
10 000 ¹⁾	Size 4	10k
20 000 ¹⁾	Size 5	20k

Range Selection

Without	A0
Dual range sensor, rated torque 1:10 (Measuring range selection)	A1
Dual range sensor, rated torque 1:5 (Measuring range selection)	A2

Output Signal

Analog output ±10 VDC	B1
Frequency output 100 ±40 kHz	B2

Increased Accuracy

Without	0
---------	---

¹⁾ no range selection A1 and A2 possible

Type 4510B

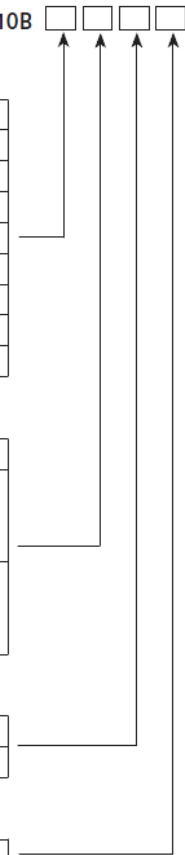

Order Example:

Type 4510B100A0B10

Measuring torque flange: Rated torque 100 N-m, without range selection: A0, Analog output ±10 VDC: B1, without increased accuracy: 0

16. Declaration of Conformity



EC Declaration of Conformity EG-Konformitätserklärung Déclaration de conformité CE

Manufacturer Hersteller Fabricant	Kistler Lorch GmbH 73547 Lorch Germany
---	---

declares that the product/erklärt, dass das Produkt/déclare que le produit

Name/Name/Nom	Torque Measuring Flange / Drehmoment-Messflansch / Torque Capteur
Type/Typ/Type	4510B...
Modules/Module/Modules	-
Options/Optionen/Options	all/alle/toutes

relates with the following standards/mit den folgenden Normen übereinstimmt/
est conforme aux normes suivantes

EMC Emission EMV Störaussendung Emission EMC	EN 61000-6-4:2011-09	(Class A)
EMC Immunity EMV Störfestigkeit Immunité EMC	EN 61000-6-2:2006-03	

Following the provisions of directive/Gemäss den Bestimmungen der Richtlinie/Conformément
aux dispositions de directive

2004/108/EG	(EMC / EMV / EMC)
--------------------	--------------------------

Lorch, January 2014

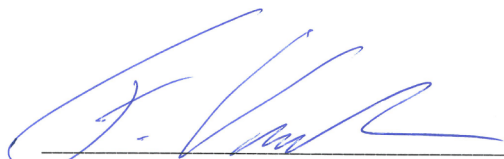

Franz Winter
General Manager

17. Index

A

Adjusting and Calibrating.....	26
Application and Typical Features.....	6

C

Calibration Device.....	27
Connection Diagram.....	15
Control Signal.....	40

D

Description of the Measuring System.....	8
Determining Sensor Data.....	44
Digital Output.....	14
Dimensions.....	53

E

Electrical and Mechanical Commissioning.....	25
Electrical isolation.....	11
Error Messages.....	32

G

General Electrical Specifications.....	51
--	----

H

help.....	4
-----------	---

I

Instandsetzung Messwelle.....	50
Interface Parameters.....	31

M

Maintenance.....	49
Making Torque Measurements.....	29
Measuring Commands.....	47
Measuring Range Selection.....	14
Measuring Rates.....	34

Mechanical Calibration.....	27
Messwelle instandsetzen.....	50

O

Ordering Key and Accessories.....	55
-----------------------------------	----

P

Plug Allocation.....	13
Power consumption.....	11
Principle of Galvanic Isolation.....	12

Q

Qualities After Switching Measuring Range ...	29
---	----

R

Range Selection.....	39
Repairing the Measuring Shaft.....	49
Requesting Torque Values.....	35
RS-232 Drehmoment Interpretation.....	35
RS-232 Kommando INP:CONT:STAT?.....	40
RS-232 Kommando INP:GAIN:MULT:OFF.....	39
RS-232 Kommando M?.....	35
RS-232 Kommando MEAS:TORQ?.....	35
RS-232 Kommando MEAS?.....	35
RS-232 Kommando TRIG:MODE:MEAS.....	43
RS-232C Communication.....	30

S

Speed Measurement.....	10
Supply.....	11

T

Technical Data.....	51
Typical Measuring Sequence.....	37

V

Value Query.....	41
------------------	----