

p-T-Sensor

Type 6188AA...

for Mold Cavity Pressure and Temperature with Front $\varnothing 1$ mm

Sensor for combined measuring of mold cavity pressure up to 2 000 bar and contact temperature in the cavity is designed for injection molding of plastics. Design without diaphragm but with flat front.

- Pressure sensor with integrated thermocouple for pressure and temperature measurement
- Mounting dimensions compatible with Kistler pressure sensor Type 6183A...
- Sensor cable replaceable by Kistler factory

Description

The Sensor for mold cavity pressure and temperature has a front diameter of 1 mm.

The pressure acts over the entire front of the sensor and is transmitted to the crystal measuring element, which produces a proportional electric charge ($pC = \text{Picocoloumb}$). This is converted into a voltage 0 ... 10 V in the amplifier and is then available as an amplifier output.

The contact temperature of the melt is measured on the front of the sensor by one pair of thermocouples, type K (NiCr-Ni). The sensor front can not be machined. The small sensor dimensions result in a short response time of the temperature sensor. The rugged combi-cable feeds the pressure signal as well as the temperature signal to two connectors.

Sensors without connectors Type 6188AAG are available for multi-cavity molds. The charge cable can then be connected to the multi-channel connector Type 1708A... or 1710A... and the two temperature conductors to the temperature amplifier Type 2205A... .

Application

Suggested applications are complex and compact injection molds in the field of medical, electrical and precision molding industries. The sensor measures the mold cavity pressure and the contact temperature of the molding in the cavity. It is suitable in

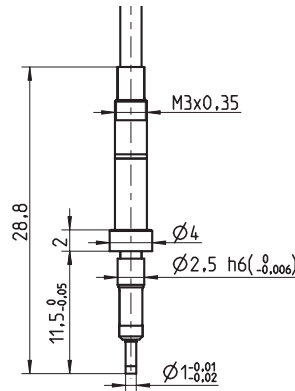

industrial applications for optimising monitoring and controlling the injection molding of thermoplastics and elastomers. The additional temperature data provides valuable process information. This is particularly useful in the analysis of part dimensions, as well as in the evaluation of knit lines in components.

Technical Data

Range	bar	0 ... 2000
Overload	bar	2500
Sensitivity	pC/bar	$\approx -4,8$
Linearity, all ranges	%FSO	$\leq \pm 1$
Thermocouple, Type K		NiCr-Ni
Operating temperature range		
Mold (Sensor, cable, connector box)	$^{\circ}C$	*0 ... 200
Melt (at the front of the sensor)	$^{\circ}C$	<450
Insulation resistance		
at 20 $^{\circ}C$	T Ω	100
at 200 $^{\circ}C$	T Ω	1

* During machine down-time, the mold temperature may be allowed to rise to 240 $^{\circ}C$ without damaging the sensor. However, measuring errors may occur.

6188AA_000-887e-01.11

QUALITY MOLDING
powered by Kistler

This information corresponds to the current state of knowledge. Kistler reserves the right to make technical changes. Liability for consequential damage resulting from the use of Kistler products is excluded.

©2010 ... 2011, Kistler Group, Eulachstrasse 22, 8408 Winterthur, Switzerland
Tel. +41 52 224 11 11, Fax +41 52 224 14 14, info@kistler.com, www.kistler.com
Kistler is a registered trademark of Kistler Holding AG.

Cable and Amplifier for Measuring Chain with Sensor Type 6188AA...

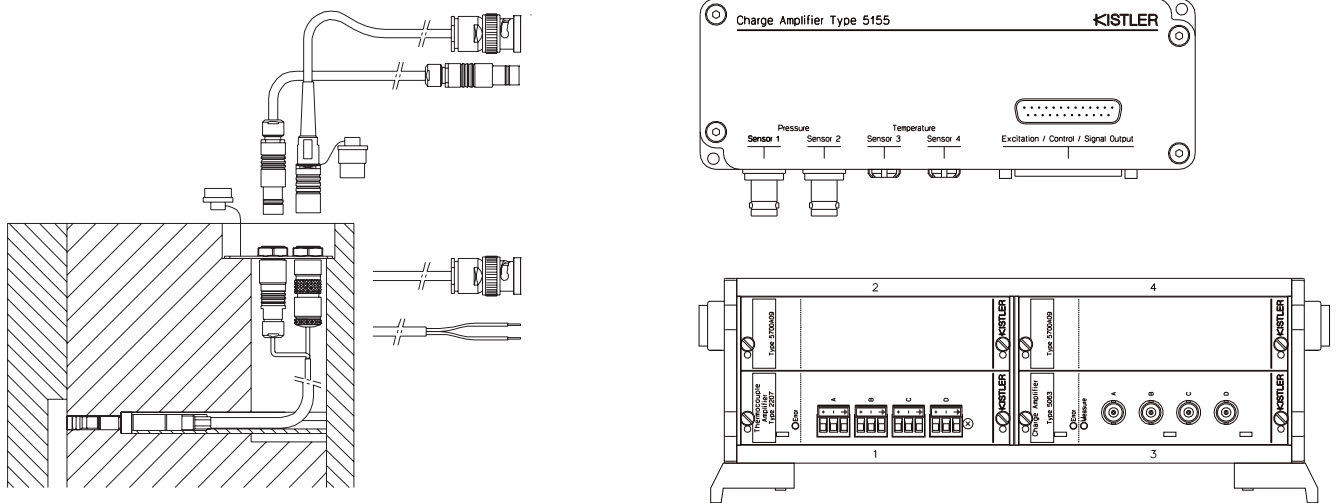

Cable Type 1667B... (BNC connector) for charge	Cable Type 1672B... (TNC connector) for charge	Compensating Line Type 2295A... for Temperature	Compensating Line Type 2290A... (Open Ends) for Temperature
Type 5155AxxBx	Type 5155AxxAx	Type 5155AxxAx	Type 2207A in Type 2859A...
Type 5155AxxDx	Type 5155AxxCx	Type 5155AxxBx	Type 2207A in Type 2865A...
Type 5063A1 in Type 2859A...		Type 5155AxxCx	
Type 5063A1 in Type 2865A...		Type 5155AxxDx	

Fig. 1: Sensor Type 6188AA... with charge and temperature amplifier Type 5155A... or signal conditioner Type 2859/2865A...

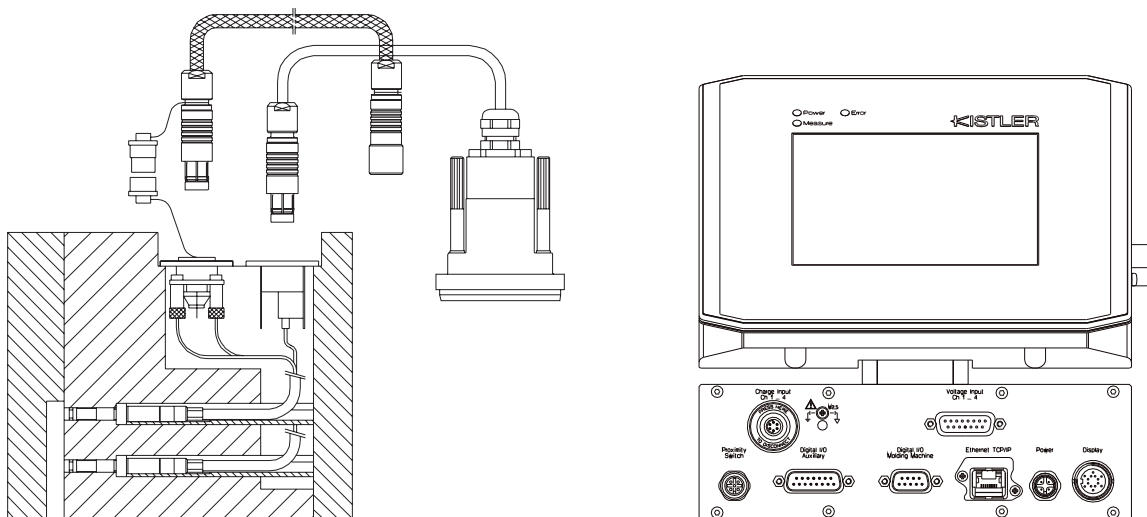

4-Channel Cable Type 1995A... to Connector Type 1708A... for Charge	4-Channel Cable Type 1457A1A... to Temperature Amplifier Type 2205A... for Temperature
Type 2869A/B0xx	Type 2869A1xx
Type 2869A/B1xx	Type 2869B...

Fig 2: Sensor Type 6188AA... with monitoring system CoMo Injection Type 2869...

6188AA_000-887e-01.11

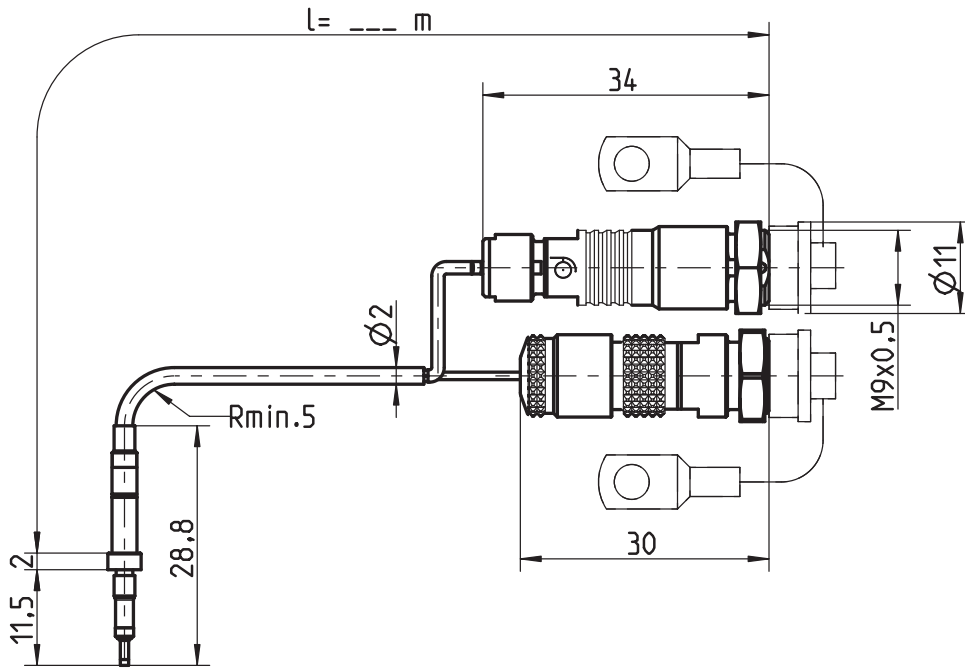

Fig. 3: Sensor Type 6188AA... with connectors for pressure and temperature signal

Installation Examples

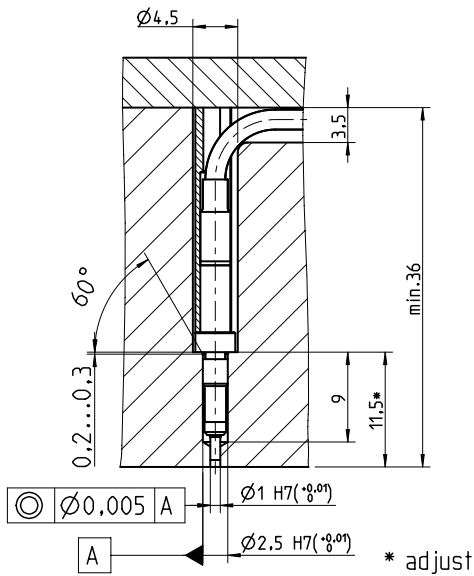

Fig. 4: Mounting with spacer sleeve Type 6464A3

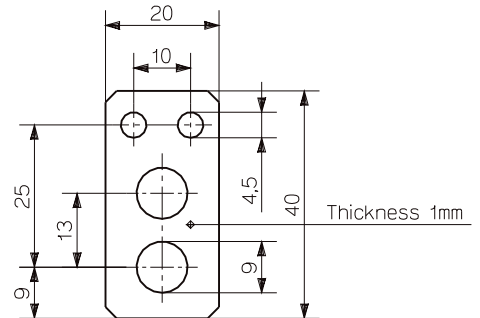

Fig. 5: Mounting plate (Art. No. 3.520.1015)

6188AA_000-887e-01.11

Mounting

The sensor is installed with the spacer sleeve Type 6464A3 in the stepped hole.

Since the sensor forms part of the cavity wall, it must be installed in such a way that its front is exactly flush. The sensor is centered in the diameter 2,5 mm/H7 hole.

The cable must be installed completely in the mold. The two connectors are attached in the mounting plate which is mounted into the mold.

The combi-cable uses the single-wire technique, i.e. the pressure signal is transferred via a single cable and the mold acts as a shield.

Accessories Included

	Type/Art.No.
• Spacer sleeve (L = 50 mm)	6464A3
• Mounting plate	3.520.1015
• Connector (charge)	5.511.364
• Connector (temperature)	5.511.246
• Cap (2 pieces)	7.621.115
• Checking tool	3.050.241
• Identification plate	3.520.1016

Optional Accessories

	Type/Art.No.
• High-temperature extension cable (pressure) Fischer SE102 A014 – BNC pos. Length 2 m	1667B2
Length 5 m	1667B5
• High-temperature extension cable (pressure) Fischer SE102 A014 – TNC pos. Length 2 m	1672B2
Length 5 m	1672B5
• Compensation lead (Temperature) Connection for Type 5155A... Length 2 m	2295A2
Length 5 m	2295A5
• Compensation lead (Temperature) One way open ended Length 2 m	2290A2
Length 5 m	2290A5
• Extraction tool	1358A
• Dummy sensor	6579

Optional connectors and temperature amplifiers

To be used only with Type 6188AAG

• 4-channel connector (charge)	1708A...
• 8-channel connector (charge)	1710A...
• 2-channel temperature amplifier	2205A121
• 2-channel temperature amplifier	2205A141
• Cable stripping tool	1367

Ordering Key

Type 6188A		<input type="checkbox"/>	<input type="checkbox"/>
Basic Type	A	↑	↑
Cable length (L = 0,4 m)	0,4		
Cable length (L = 0,8 m)	0,8		
Cable length (L = 1,2 m)	1,2		
Cable length (L = 1,6 m)	1,6		
Cable length (L = 2,0 m)	2		
Combi-cable with special length, specify cable length L in m (L _{min} = 0,15 m / L _{max} = 3,5 m)	sp		
Sensor without connector, Cable length l = 2,0 m	G		