

Universal Neck Load Cell

Type M55636A...

Six-axial

Type M55636A... is designed to measure forces and moments in the upper neck and/or in the lower neck of the crash test dummies Q0 ... Q6.

- Six-axial (F_x , F_y , F_z , M_x , M_y , M_z)
- UPS module available
- Low linearity errors and hysteresis errors
- Kistler system cabling
- Polarities according to SAE J211/1

Description

The load cell is made of elements on which forces are transmitted. The mechanical deformation element, applied with strain gage, serves for mechanical electrical deformation. The effectiveness of the load cell resembles the behavior of a spiral spring. The forces to be measured create mechanical stretches and buckling in the gaging member. In order to avoid linearity errors, the deformation paths are constructively held small (high rigidity). Thus a proportional behavior is realized.

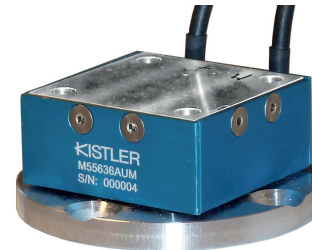

The force and moment proportional resistance variations are measured by a Wheatstone-type bridge circuit. The load cell is available with UPS module which is integrated in an external housing in the wiring or in the connector. Customized cable lengths and connectors with specific pin assignments are optionally available. When the load cell is applied to the location lower neck, polarities of the axes F_x and M_x must be changed to conform to SAE J211/1.

Technical Data

Axial Data		F_x	F_y	F_z	M_x	M_y	M_z
Measuring range	kN	5	5	6			
	N·m				150	150	80
Bridge output voltage (typ.)	mV/V	2	2	1	2	2	3
Sensitivity (typ.)	$\mu\text{V}/\text{V}/\text{kN}$	400	400	167			
	$\mu\text{V}/\text{V}/\text{N}\cdot\text{m}$				13	13	31
Bridge resistance	Ω	350	350	700	350	350	350 ¹⁾
Ultimate load, static	%	150	150	150	150	150	150

General Data

Supply voltage ²⁾	VDC	2,5 ... 15
Insulation resistance ³⁾	G Ω	>10
Operating temperature range	$^{\circ}\text{C}$	-20 ... 80
Storage temperature range	$^{\circ}\text{C}$	-30 ... 90
Amplitude non-linearity (typ.)	%	<1
Hysteresis (typ.)	%	<1
Channel cross talk	%	<5
Bridge zero output (typ. / max.)	mV/V	0,01 / 0,03
Weight (without cable)		120

All specifications are typical at 25 $^{\circ}\text{C}$ and rated at 10 V sensor supply voltage, unless otherwise specified.

¹⁾ Up to serial number 0004546324 (up to year of construction 2015) the bridge resistance of the load cells is 700 Ω in M_z . Please mind the first calibration!

²⁾ With UPS module 9 ... 12 VDC

³⁾ All wires to load cell housing, measured with 500 VDC

Application

Type M55636A... is directly assembled at the designated location in the dummy and provides important information about the loads on the human body occurring during a crash test.

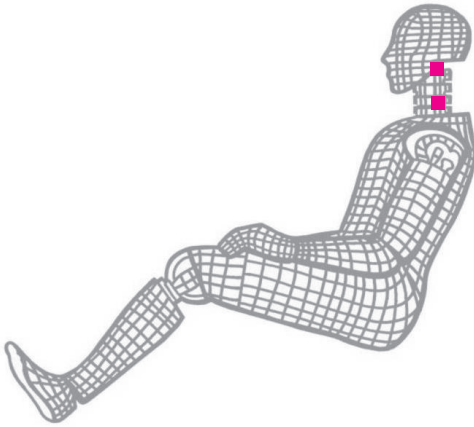

Fig. 1: Dummy application, locations upper neck & lower neck

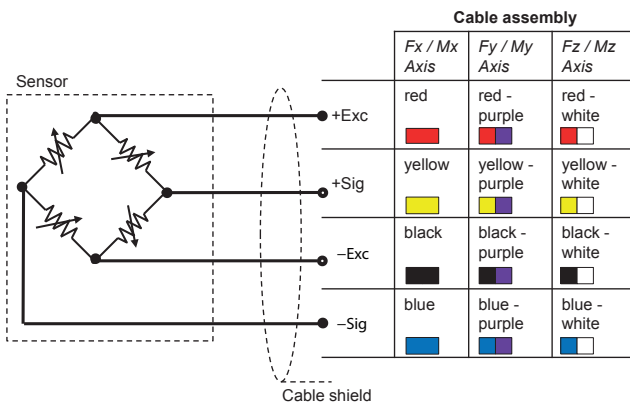

Fig. 2: Cable assembly

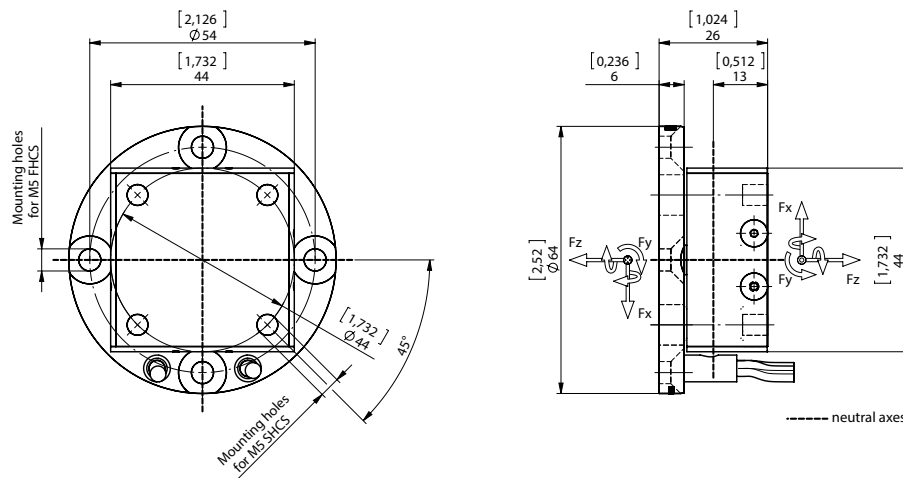

Fig. 3: Dimensions in mm

Included Accessories

- None

Optional Accessories

- Add. label with serial number, plug side
- UPS module
- Add. label with ID number at sensor
- Add. shunt

Type No.

M015KABID
on request
M015KABID
on request

Ordering Key

Type M55636A

Design

Standard UM

Cable Length before Electronics

0 cm	00
<10 cm (digit x 1 cm)	C#
10 cm ... 9,9 m (digit x 10 cm)	##
10 m ... 90 m (digit x 10 m)	D#

Electronics

Sensor detail, as per type declaration force-moment TP-650-2 #

Cable Length after Electronics

0 cm	00
<10 cm (digit x 1 cm)	C#
10 cm ... 9,9 m (digit x 10 cm)	##
10 m ... 90 m (digit x 10 m)	D#

Connector

Conn. type, as per TP-600 #-

Conn. type assignment, as per TP-600 -#