

Strain Gage Miniature Load Cell

Type 4577A...

for Compression Forces, 0,1 ... 200 kN

A high value/performance ratio and robust design characterize the compressive force miniature load cell Type 4577A... even in the high measuring ranges.

- Measuring ranges from 0 ... 0,1 kN up to 0 ... 200 kN
- Small size
- For static and dynamic measurements
- Stainless steel construction
- Standardized output signal 1 mV/V



Description

Force sensor Type 4577A... is designed as a flat, circular disc. The measuring element inside the body carries a strain gage full bridge which outputs a voltage directly proportional to the measurement variable on the application of a force.

The load application knob for receiving compression forces is an integral part of the sensor. The measurement force must be applied centrally and without any transverse vectors. Ensure that the sensor Type 4577A... is mounted on a smooth and even surface.

Application

Their small dimensions enable load cells Type 4577A... to be used for measuring static and dynamic forces in restricted spaces.

Force sensors of this type have a hermetically sealed body, allowing it to be used under dirty and corrosive industrial conditions.

Applications include:

- Press-fit operations
- Draw-pull forces
- Spring power measurements
- Measurements of cutting forces
- Force measurements on mounting devices
- Functional tests

Technical Data

Measurement direction		compression
Measuring ranges	kN	0 ... 0,1 up to 0 ... 200
Limiting force	%	150
Dynamic load	%	50 (recommended) 70 (maximum)
Operating temperature range	°C	-20 ... 100
Rated temperature range	°C	15 ... 70
Temperature influence		
On zero	%FSO/K	≤±0,02
On span	%FSO/K	≤±0,03
Weight	kg	≈0,04 ... 1,2
Material		stainless steel 1.4542
Degree of protection (sensor body) (acc. to IEC/EN 60529)		IP64
Bridge resistance: strain gage		full bridge circuit
Measuring range 0,1 ... 2, 200 kN	Ω	350 nominal*
Measuring range 5 ... 100 kN	Ω	700 nominal*
Accuracy:		
Measuring ranges up to 1 kN	%FSO	≤±0,25
Measuring ranges of 2 kN (combined value for non-linearity hysteresis and repeatability)	%FSO	≤±0,5
Supply voltage:		
Recommended	VDC	5
Maximum	VDC	10
Sensitivity:		
Measuring ranges up to 1 kN	mV/V	1 ±0,25 %
Measuring ranges of 2 kN	mV/V	1 ±0,5 %

* Deviations may occur.

Dimensions

Meas. Range [kN]	Dimensions [mm]																Weight [kg]	Natural frequency [kHz]
	øD1	øD2	øD3	øD4	øD5	H1	H2	øT	øA	øB	øC	K	L	M	N	G		
0 ... 0,1	31,8	29,4	20,6	8,1	19	9,9	8,1	25,5	-	3	2	-	40	2,5	3	M2,5	0,07	>2
0 ... 0,2	31,8	29,4	20,6	8,1	19	9,9	8,1	25,5	-	3	2	-	40	2,5	3	M2,5	0,07	>3
0 ... 0,5	31,8	29,4	20,6	8,1	19	9,9	8,1	25,5	-	3	2	-	40	2,5	3	M2,5	0,07	>5
0 ... 1	31,8	29,4	20,6	8,1	19	9,9	8,1	25,5	-	3	2	-	40	2,5	3	M2,5	0,07	>8
0 ... 2	31,8	29,4	20,6	8,1	19	9,9	8,1	25,5	-	3	2	-	40	2,5	3	M2,5	0,07	>11
0 ... 5	31,2	28,7	21,1	8,1	19,5	9,9	8,1	25,5	7	4,8	3	10,4	30,7	3,8	3	M2,5	0,11	>17
0 ... 10	31,2	28,7	21,1	8,1	19,5	9,9	8,1	25,5	7	4,8	3	10,4	30,7	3,8	3	M2,5	0,11	>25
0 ... 20	37,6	35	27,4	10,7	25,7	16	14	31,5	7	4,8	3	10,4	30,7	3,8	3	M2,5	0,17	>25
0 ... 50	37,6	35	27,4	10,7	25,7	16	14	31,5	7	4,8	3	10,4	30,7	3,8	3	M2,5	0,17	>40
0 ... 100	50,3	47	34,8	15,2	34,7	25,4	22,4	42	7	4,8	3	10,4	30	4,8	6	M4	0,35	>40
0 ... 200	76,2	74	46	20	45	38,1	33,5	60	7	4,5	3	11	45	6	6	M4	1,2	>40

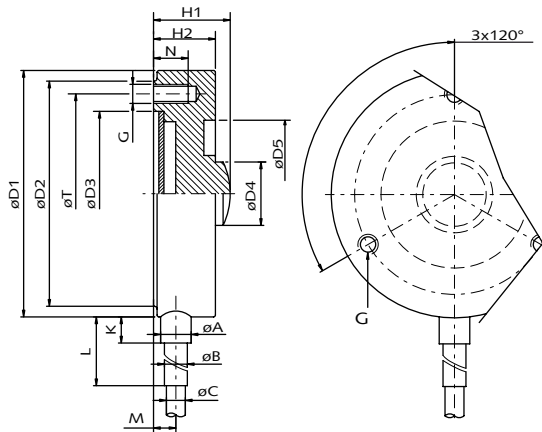

Assembly requirements for support area:

Height		≈sensor height
Hardness	HRC	60
Evenness	µm	<5
Parallelism	µm	<30

Optional Accessories

- Connection cable, 5 m, 6 pin/6 pin **Type** KSM071860-5
- Connection cable, 5 m, 6 pin/open ends **Type** KSM103820-5

Included Accessories

- None

Ordering Key

Measuring range [kN]	Type 4577A
0,1	0,1
0,2	0,2
0,5	0,5
1	1
2	2
5	5
10	10
20	20
50	50
100	100
200	200

Connector Plug

6 pin M16 circular connector ¹⁾	C1
9 pin D-Sub connector ²⁾	C3

Advice for connector plug C1 and C3

- ¹⁾ C1 connector is applicable for DMF-P family
- ²⁾ C3 connector is applicable for maXYmos family

Electrical Connection C1

approx. 2 m shielded, highly flexible cable, 6 pin M16 circular connector

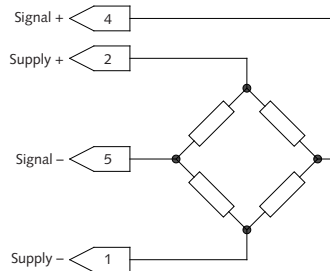
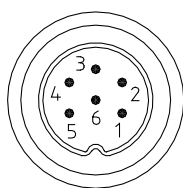

Electrical Connection C3

approx. 2 m shielded, highly flexible cable, 9 pin D-Sub connector

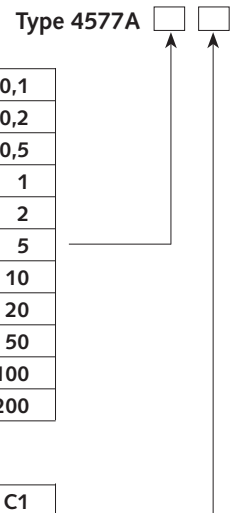
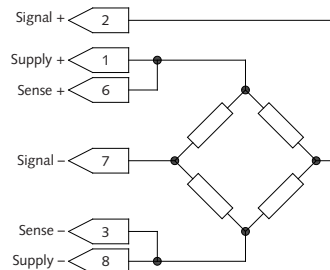
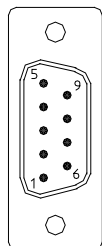

4577A_000-674e-09.18