

Water-Cooled Mounting Adaptor

for Single and Triaxial Accelerometers

Type 8550A...

The Type 8550A1 water-cooled mounting adaptor is specifically designed for use on high temperature surfaces up to 550 °C [1,022 °F], such as the exhaust manifold.

- Compatible with most single-axis and triaxial IEPE 165 °C [330 °F] Kistler sensors
- Through hole mounting from the bottom of the adaptor for easy orientation of X and Y axis of triaxial sensors, such as Type 8766A
- U-Clamp compatibility for exhaust adaptation
- For surfaces up to 550 °C [1,022 °F]
- Compatible with Kistler Type 2621F cooling system for engine pressure sensors



Description

Type 8550A1 water-cooled mounting adaptor is made of anodized aluminium with a mass of 36 grams. It allows for mounting of all IEPE 165 °C [330 °F] single-axis or triaxial sensors from Kistler, ensuring a frequency response up to 2 kHz at ±5 %. The adaptor can be mounted onto any hot surface up to 550 °C [1,022 °F] using clamps available from the market or customer made stainless steel adaptor plates welded to the hot surface. Its through hole mounting concept allows easy orientation of all axis of triaxial sensors even when screw mounted to the cooling adaptor.

WARNING: Kistler is providing some recommendations for a few specific cases: The user should be aware that each situation is different and the cooling adaptor performances will vary depending on flow rates, cooling water temperature, tubing lengths or utilized pumps, sensor mounting vs. hot surface (above, below, etc.)...

Mounting Recommendations Using a Welded Steel Plate

One possible mounting option of the cooling adapter would be using a stainless steel block welded onto a hot surface.

A minimum thickness of 13 mm [0.5 in] would be adequate to accommodate (1 ... 2 diameters of thread engagement of #8 bolts) a water flow rate that keeps the top surface of the WCMA at 50 °C [120 °F], and assumes the stainless steel weld block is welded onto a surface that is 550 °C [1,022 °F] (welded to surface) and adequate air flow to keep the air around the sensor near room temperature (22 °C [70 °F]). If the weld to the surface is hotter than 550 °C [1,022 °F], or if the cooling water temperature is hotter than 50 °C [120 °F], then the recommended thickness should be bigger.

Dimensions

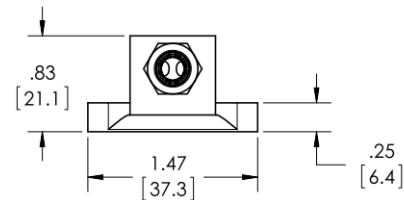
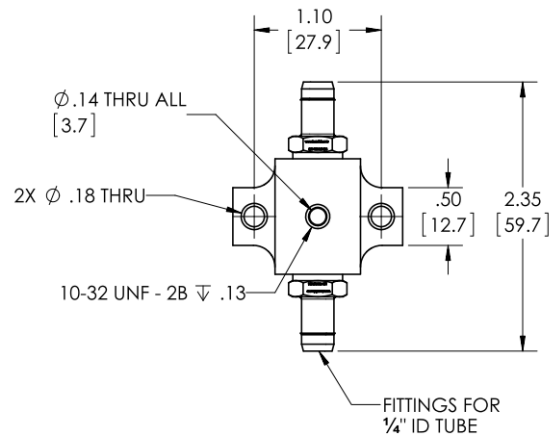

Dimensions are noted as in [mm], unless otherwise noted.

8550A_003-249e-04.17

Technical Data

Type Number	Unit	8550A1
--------------------	-------------	---------------

Physical

Weight with fittings	grams	36.1
----------------------	-------	------

Mounting holes

Distance (center-to-center)	mm [in]	27.9 [1.10]
Hole diameter	mm [in]	4.5 [0.18]
Hose fittings	Barbed fitting for ¼" ID tube	
Max. Temp. for Base Surface	°C [°F]	550 [1,022]

Accessories

Mounting stud	(1) 8402, (1) 8411, (1) 8410, (1) 8430K03
---------------	--

1 g = 9.80665 m/s², 1 in = 25.4 mm, 1 Gram = 0.03527 oz, 1 lbf-in = 0.113 N-m

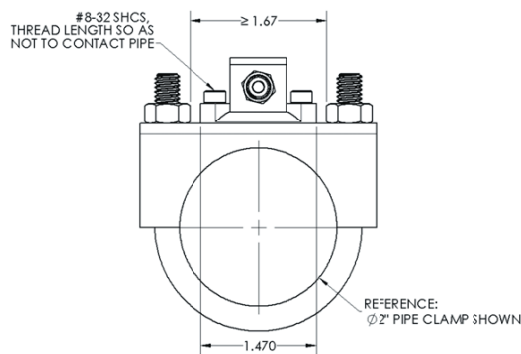

Fig. 1: Clamp size

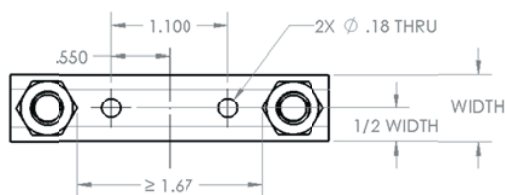

Fig. 2: Align and drill holes

Guideline When Using Thermal Grease

Thermal grease is not necessary for the water cooled mounting adapter to function. Thermal grease may be used to increase thermal conductivity between the cooling adapter and a through bolt used to mount the sensor. Care should be taken in the selection and application of the thermal grease.

Guideline for General Usage

Kistler recommends allowing the water cooling system to run for a few minutes before starting the test, which generates heat. This will help prevent damage to the sensor and water-cooled mounting adapter.

Mounting Recommendations Using a Muffler Clamp

For adaptation on exhaust manifolds, Kistler recommends the useage of muffler clamps.

To do this, it is recommended to choose a muffler clamp that has enough space between the bolts to fit the water-cooled mounting adaptor and allow space for sockets to tighten the U-bolt nuts (see Fig. 1).

In addition, it is recommended to choose a muffler clamp that has a gap big enough to fit the mounting nuts (see Fig. 3). #8 or M4 SHCS can be used.

In order to prepare the mounting holes, align and drill holes in the muffler clamp and remove the burrs (see Fig. 2). Then attach the water-cooled mounting adaptor using two #8 (M4) nuts and bolts.

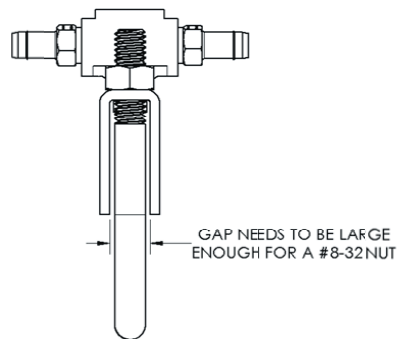

Fig. 3: Gap size

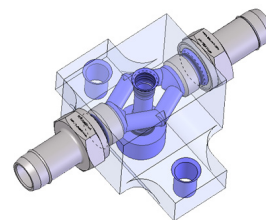

Fig. 4: Type 8550A waterflow path and mounting threads

Here are a few selection characteristics to consider:

- high viscosity to prevent leakage
- high flash point or is non-flammable
- high thermal conductivity*

Follow the manufacturer's cleaning recommendations to remove excess thermal grease from all surfaces prior to mounting the water-cooled adapter.

*A thermal grease with thermal conductivity in the range of .65 to .85 W/(m*K) reduced the sensor mounting surface temperature by ≈4% when compared with no thermal grease.

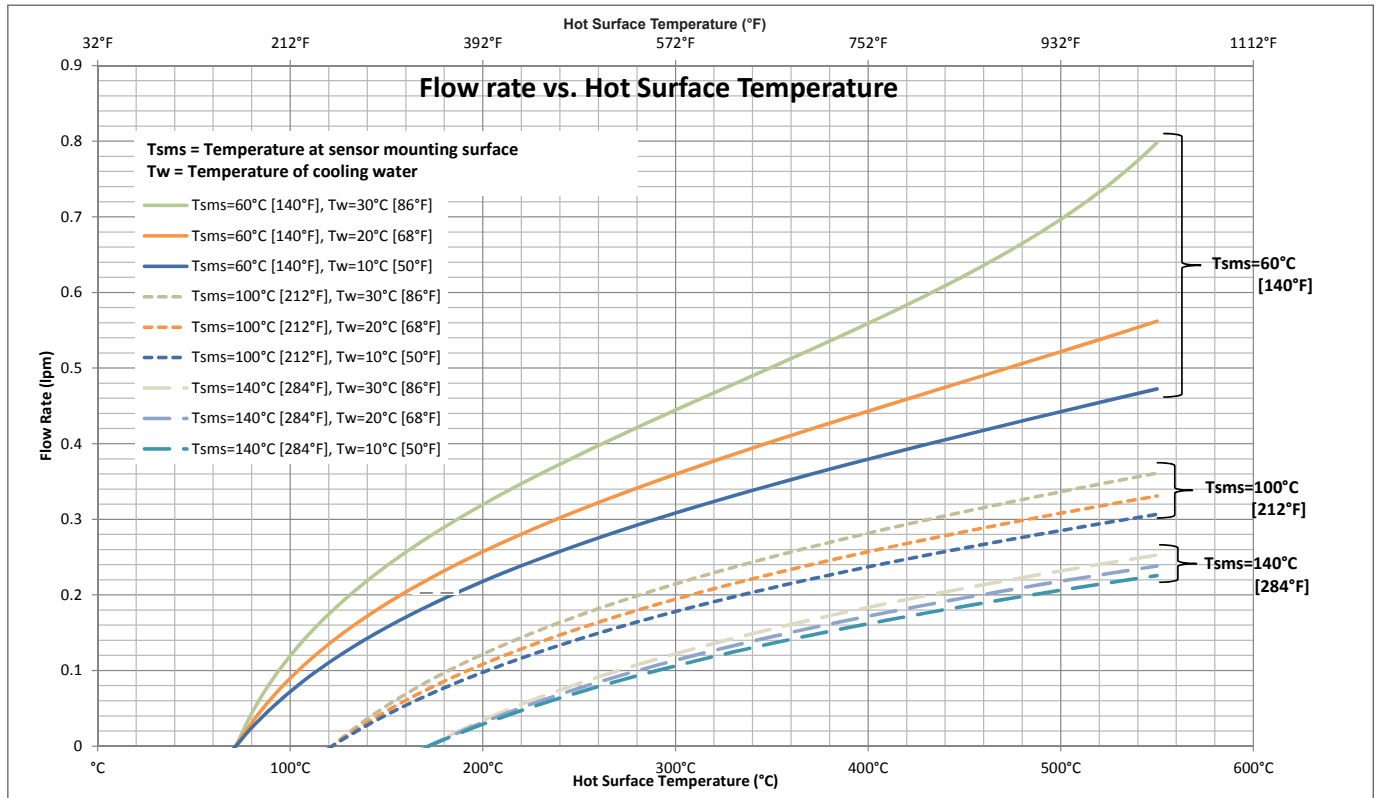

Fig. 5: Minimum flow rate recommendations depending on the expected temperature at the water-cooled mounting adaptor base

Figure 5 can be used to determine:

- (1) The flow rate needed for a given cooling water temperature and hot surface temperature.
- (2) The cooling water temperature needed for a given flow rate and hot surface temperature.
- (3) The maximum hot surface temperature allowed for a given flow rate and cooling water temperature.

For example (based on temperature values in °C):

Given: The cooling water temperature, and the hot surface temperature

Find: The minimum flow rate

- (A) Select a temperature for the sensor mounting surface (Tsms), 60 °C, 100 °C or 140 °C, and the temperature for the cooling water (Tw), 10 °C, 20 °C, or 30 °C and find the corresponding curve. If necessary interpolate between curves.
- (B) Find where the curve intersects the vertical line representing the temperature for the hot surface. Then follow horizontally over, from the intersection point, to the vertical axis to find the minimum required flow rate.
- (C) If the flow rate of cooling system is higher than the rate found in (B), then the temperature at the sensor mounting surface will be less than that of the curve.

8550A_003-249e-04.17

Included Accessories

- 10-32x1/8" plug – to be used when no through bolt is used
- M4x12 mm mounting bolts
- 8-32 x 1/2" mounting bolts

Type/Mat. No.
55155067

55151205 x 2
55151206 x 2

Optional Accessories

- 10-32 to 10-32 mounting stud – to be used with Types 8703/8705 sensors
- 1/4-28 to 10-32 mounting stud – to be used with Type 8203 sensor
- 6-32x3/4" through bolt – to be used with Type 8766A050/100... sensors
- 5-40x3/4" through bolt – to be used with Type 8766A250/500/1K0... sensors
- 10-32 to 4-40 stud converter – to be used with Type 8765 sensors
- Water-cooling system

Type/Mat. No.
8402

8410

55154931

55154932

8482

2621F

Other Recommended Accessories

- For water flow: High-Temperature Firm Viton® Fluoroelastomer Opaque Tubing for chemicals with inside diameter 1/4". (e.g.: McMaster Carr Type 5119K85, 5119K86 or 5119K87)
WARNING: Tubing limited to a maximum of 200 °C [400 °F]. It should be secured away from the hot surface.
- For easy tubing orientation away from hot surface: Stainless steel elbow fitting 1/4" x 1/4" I.D. tubing (e.g. www.beveragefactory.com Model SSE-B2)

Ordering Key

Variants

Aluminum water-cooled mounting adaptor – max. interface temperature of 550 °C [1,022 °F]

Type 8550A

1

NOTE: For interface temperature higher than 550 °C [1,022 °F], please contact Kistler.

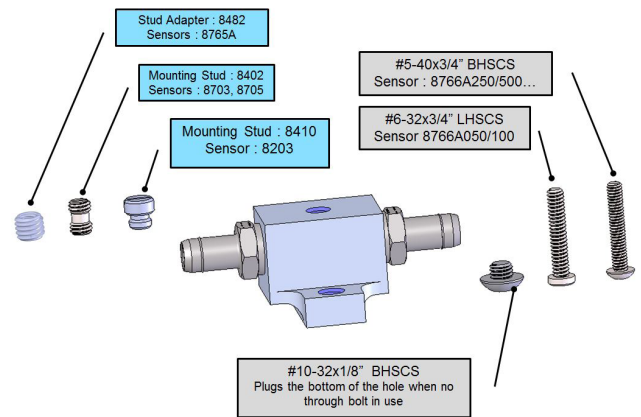

Fig. 6: Sensor mounting configurations and compatible accessories