

PinSens Force Sensor

Type 9204B...

for mold cavity pressure with diameter 12.6 mm

Quartz force sensor for the measuring range from 0 ... 10 000 N or for measuring mold cavity pressure of up to >3 000 bar during injection molding of plastics.

- Replaceable cable
- Available with single-wire technology

Description

The 9204B... sensor offers high resolution and a rugged, welded case. The charge signal (pC = pico coulombs) output by the force sensor is converted in the Kistler charge amplifier or in a monitoring unit into a proportional output voltage that is largely independent of the length of the sensor cable. The maximum possible output voltage from the standard amplifier is 10 V. In the most sensitive range this gives 1 N/V. The replaceable cables allow a wide choice of connecting cables, including the single-wire version. With single-wire technology an individual cable is shortened to the required length and connected to the connector using the proven cut and grip technique. With this arrangement the mold serves as a shield for signal transmission.

For multi-cavity applications the sensor Type 9204B... is used without the single-wire connector Typ 1839. For 4-channel applications the Sensor Type 9204B... is mounted with the Multi-Channel Connector Type 1708... and for 8-channel applications with the Multi-Channel Connector Type 1710...

Application

Although the mold cavity pressure in industrial applications is normally measured directly in the cavity, there are situations in which this is not possible, for example for reasons of space. The sensor is positioned under the ejector pin in the ejector plate, and measures the force curve by means of the ejector. This allows calculation of the actual mold cavity pressure.

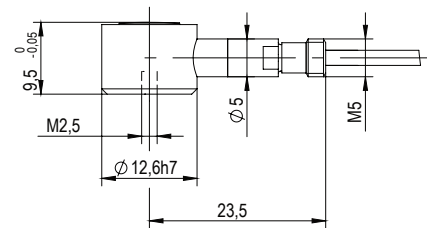

Technical data

Measuring range	N	0 ... 10 000
Calibrated partial range	N	0 ... 1 000
Overload	N	12 000
Threshold	mN	30
Sensitivity	pC/N	-1.6
Linearity, all ranges	%FSO	±2
Operating temperature range	°C	-40 ... 200
Insulation resistance		
at 20 °C	Ω	≥10 ¹³
at 120 °C	Ω	≥10 ¹²

Force sensor Type 9204BE

Indirect measuring sensor with replaceable single-wire cable. Suitable for mounting as complete module in the ejector plate.

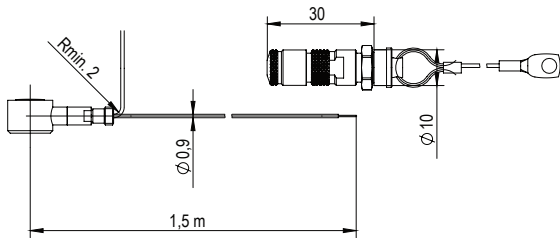

Fig. 1: Force Sensor Type 9204BE with cable and connector

Force sensor Type 9204B0.2/0.4/0.6/0.8/sp

Indirect measuring sensor with replaceable coaxial connecting cable in lengths of 0.2/0.4/0.6/0.8 m or special lengths.

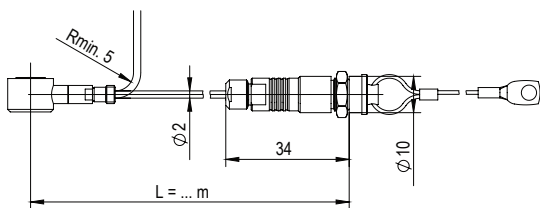

Fig. 2: Force Sensor Type 9204B0.2/0.4/0.6/0.8/sp with cable and connector

Computation of sensitivity for the pressure measurement

The front face of the ejector pin must be taken into account when mounting the force sensor for pressure measurement. The nominal sensor sensitivity (pC/N) is converted into a corresponding pressure sensitivity using the following formula.

$$\text{Calculated pressure sensitivity [pC/bar]} = \text{Nominal force sensitivity [pC/N]} \cdot \text{area of ejector pin [mm}^2\text{]} \cdot 0.1$$

The measuring range of the sensor must be taken into account when choosing the ejector pins. The larger the ejector pin area the higher the force on the sensor.

The following table shows the calculated sensitivity with the nominal sensitivity of the Type 9204B... and the maximum pressure for a selection of ejector pins.

Diameter ejector pin [mm]	Sensitivity [pC/bar]	Masimum pressure [bar]
1,6	-0,32	>3 000
2	-0,50	
2.5	-0,78	
3	-1,13	
4	-2,01	
5	-3,14	
6	-4,52	2 000
8	-8,04	1 300
10	-12,56	900
12	-18,09	650
14	-24,62	

Mounting

The PinSens force sensor has a precision ground face. The bearing surface of the ejector pin must also be finely machined, flat, rigid and exactly parallel. The sensor can be mounted with a M2,5-screw and a spring washer. Once mounted the sensor must not have any preload. A clearance of 0.03 ... 0.05 mm is recommended.

When using the single-wire technology, it must be ensured that the single-wire cable is kept in the ejector plate and that the Type 1839 connector is also mounted in this plate. When installing the connector in a different plate, electrical shielding by the mold must be ensured.

Principle of function

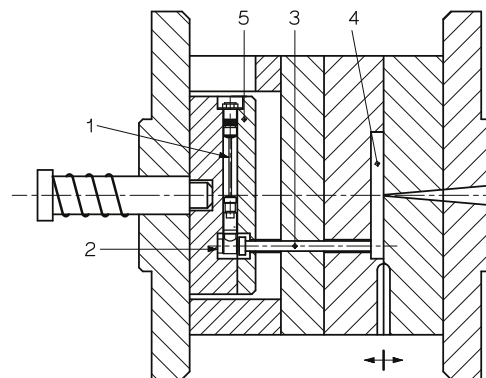

- 1 Force sensor
- 2 Thrust washer
- 3 Ejector pin
- 4 Cavity
- 5 Ejector plate

Fig. 3: Force sensor for indirect measurement of mold cavity pressure behind an ejector pin in the mold using the example of the Type 9211.

9204B_000-128e-03.25

Cable and amplifier for measuring chains with sensor Type 9204B...

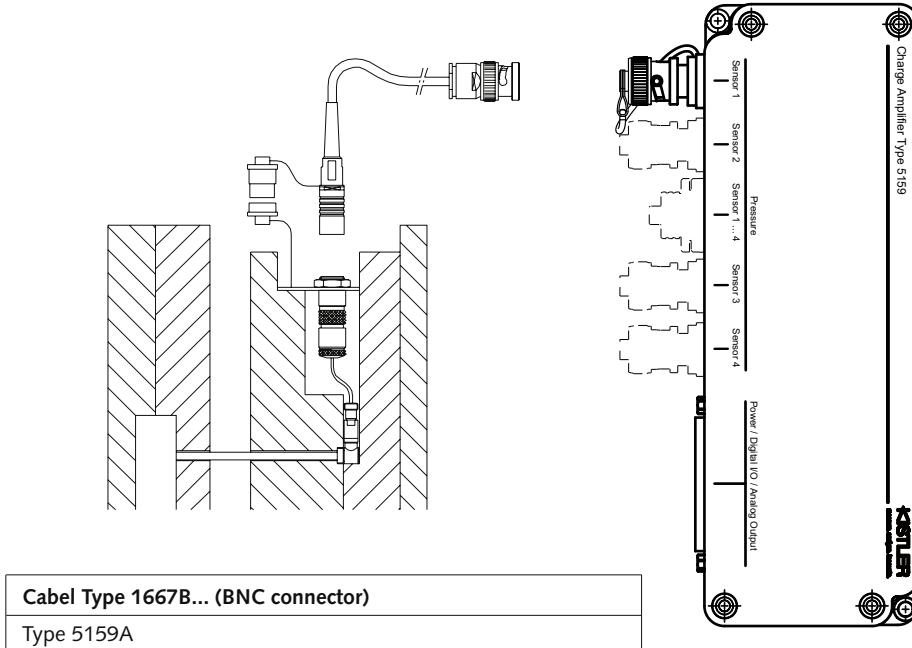
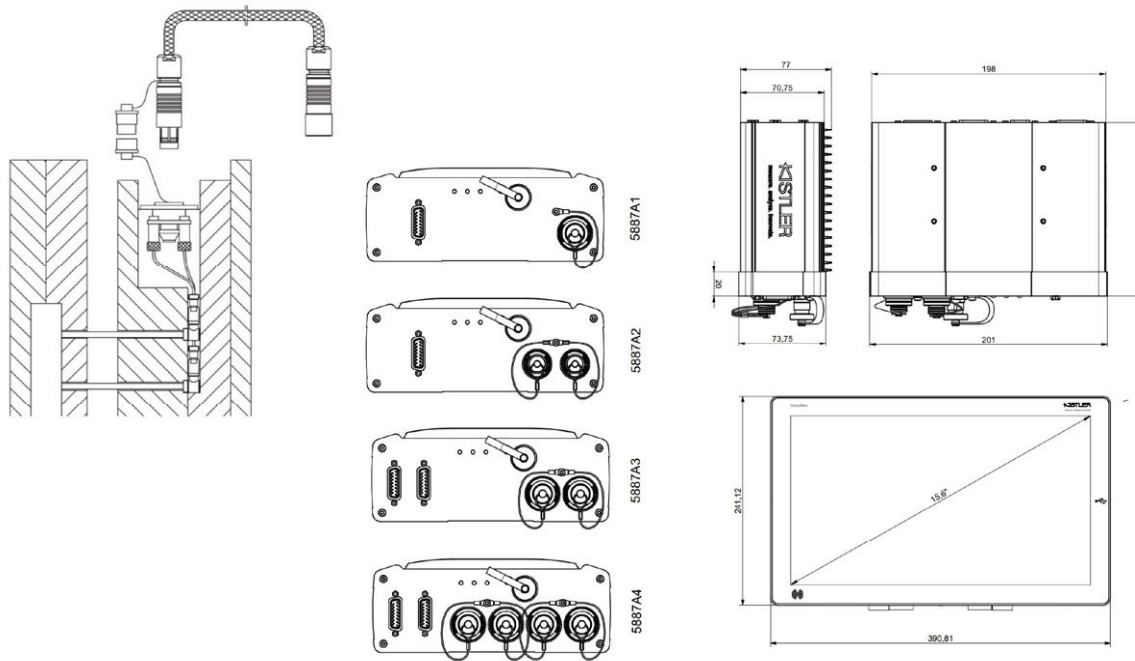

Fig. 4: Sensor Type 9204B... with charge amplifier Type 5159A



4-channel cable type 1995A... to plug type 1722A4...	8-channel cable type 1997A... to plug type 1722A8...
Type 5887A1	Type 5887A2
	Type 5887A3
	Type 5887A4

Fig 5: Sensor Type 9204B... with monitoring system ComoNeo Type 5887...

9204B_000-128e-03.25

Mounting examples

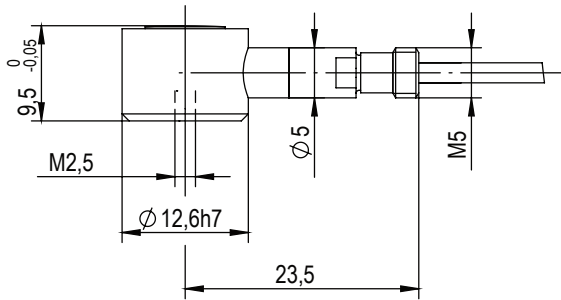

Fig. 6: Sensor Type 9204

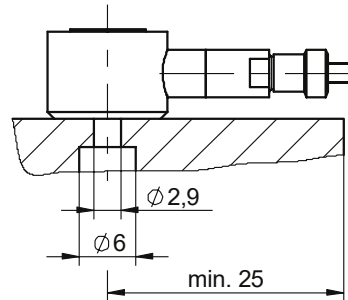
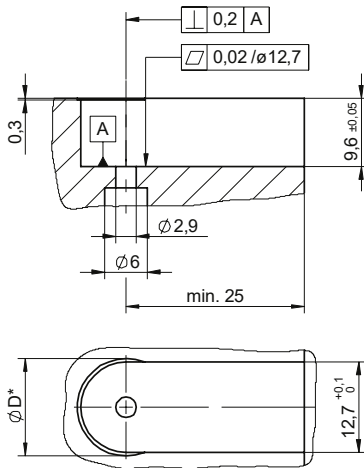
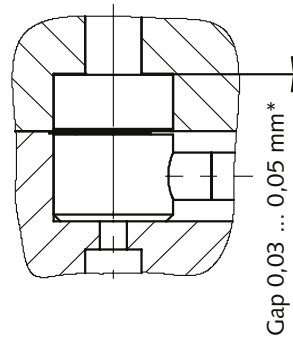

Fig. 7: Mounting in retaining plate



D* = 0.5 mm larger than the diameter of the ejector head

Fig. 8: Mounting bore



* Sensor should not be preloaded. Consider this value as a minimum during construction and realisation of the mold. Depending on deformation, it could be necessary to have a bigger gap. Check clearance before mounting the sensor.

Fig. 9: Mounting sensor Type 9213 with ejector pin

9204B_000-128e-03:25

Accessories included

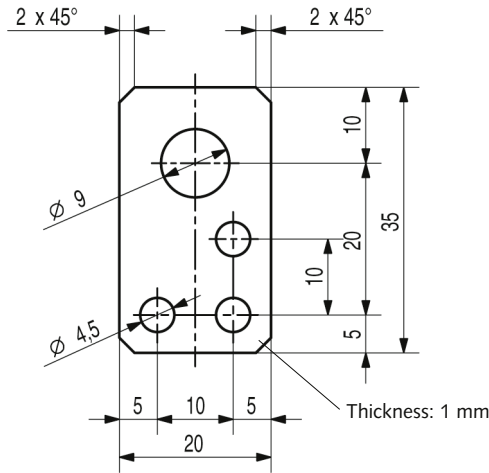

Fig. 10: Mounting plate Mat. No. 65005208

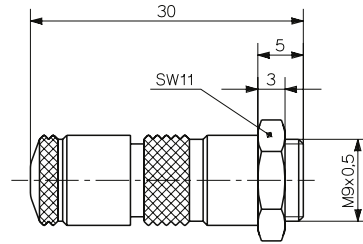

Fig. 11: Single-wire connector Type 1839

Accessories included

PinSens force sensor Type 9204B with single-wire cable

- Connector 1839
- Mounting plate 65005208
- Cheese-head screw 65012816
- Spring washer 65013328
- Identification plate 65005190

Miniature force sensor Type 9204B0.2/0.4/0.6/0.8/sp with coaxial cable and connector

- Mounting plate 65005208
- Cheese-head screw 65012816
- Spring washer 65013328
- Identification plate 65005190

Optional accessories

High temperature extension cable Fluoropolymer with BNC connector

- Length 2 m 1667B2
- Length 5 m 1667B5
- Length 10 m 1667B10
- Special length (between 0.5 m and 8 m) 1667Bsp

High temperature extension cable with metal tubing and BNC connector

- Length 2 m 1661A2
- Length 5 m 1661A5
- Length 10 m 1661A10
- Special length (between 0.5 m and 8 m) 1661Asp
- 4-channel connector 1708
- 8-channel connector 1710
- Sensor Tester for cavity pressure sensors 5495C

Single-wire connection cable

Single-wire M4 x 0.35 pos.

- Length 1.5 m 1666A2
- Length 5.0 m 1666A4
- Single-wire crimped pin 1666AZ2
- Length 1.5 m 1666AZ4
- Length 5.0 m 1666AZ4

Ordering key

Single-wire cable, L = 1.5 m	E
Coaxial Cable	0,2
Coaxial Cable	0,4
Coaxial Cable	0,6
Coaxial Cable	0,8
Coaxial cable with special length, specify length L in m (L _{min} = 0.1 m / L _{max} = 5 m)	-sp
Sensor Type 9204BE without connector	G

Type 9204B

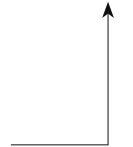

9204B_000-128e-03.25