

Mold Cavity Pressure Sensor

Unisens® with Front $\varnothing 4$ mm

Type 6157B...

Patent No. US 6,212,963

Quartz sensor for cavity pressures up to 2 000 bar for injection molding of plastics.

- ideally suited for industrial applications
- sensor front can be machined to adapt to the cavity wall (except for coated versions of the sensor)
- exchangeable cable

Description

The Unisens quartz sensor for mold cavity pressure Type 6157BE... has a front diameter of 4 mm. An O-ring seals the annular gap of $<10 \mu\text{m}$ between sensor and mounting bore and thereby also center aligns the sensor in the bore.

The pressure acts over the entire front of the sensor and is transmitted to the quartz measuring element, which produces a proportional electric charge ($\text{pC} = \text{Picocoloumb}$). This is converted into a voltage $0 \dots 10 \text{ V}$ in the amplifier and is then available as an amplifier output.

All parts of the sensor are corrosion-resistant. The exchangeable cable is screwed to the sensor with a tight seal. The connector is self-locking and splash-proof.

For multi cavity applications the sensor Types 6157BA... and 6157BC... are used without the single-wire connector Typ 1839. The Multi Cavity Set Type 6829A... and the Multi Sensor System Type 6831B... are described in the appropriate data sheets.

This sensor is available with several Types of connecting cables (see page 2).

Application

This diaphragm-free sensor measures mold cavity pressures up to 2 000 bar during injection molding. It is particularly suitable for optimizing, monitoring and controlling the injection molding process of thermoplastics, elastomers, thermosets and SMC.

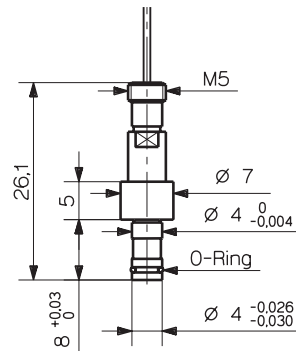

For abrasive melts (e.g. filled with glass fibers or carbon fibers, thermosets, BMC/SMC), these sensors are available as Types 6157BCE ($0 \dots 200 \text{ }^\circ\text{C}$)/BD... ($0 \dots 300 \text{ }^\circ\text{C}$) with a hardcoated front.

Technical Data

Range	bar	0 ... 2 000
Overload	bar	2 500
Sensitivity	pC/bar	-9,4
Linearity, all ranges	% FSO	$\leq \pm 1$
Operating temperature range		
Mold (sensor, cable)		
Type 6157BA.../BC...	$^\circ\text{C}$	200
Type 6157BB.../BD...	$^\circ\text{C}$	300
Melt (at the front of the sensor)	$^\circ\text{C}$	< 450
Connector	$^\circ\text{C}$	0 ... 200*
Insulation resistance		
at $20 \text{ }^\circ\text{C}$	Ω	$> 10^{13}$
at $200 \text{ }^\circ\text{C}$	Ω	$> 10^{12}$
at $300 \text{ }^\circ\text{C}$	Ω	$> 10^{10}$

* During machine down time the mold temperature may rise up to $240 \text{ }^\circ\text{C}$, without causing any damage to the sensor. Note that measuring errors may temporarily result.

6157B_000-030e-09.12

QUALITY MOLDING
powered by Kistler

This information corresponds to the current state of knowledge. Kistler reserves the right to make technical changes. Liability for consequential damage resulting from the use of Kistler products is excluded.

©1994 ... 2012, Kistler Group, Eulachstrasse 22, 8408 Winterthur, Switzerland
Tel. +41 52 224 11 11, Fax +41 52 224 14 14, info@kistler.com, www.kistler.com
Kistler is a registered trademark of Kistler Holding AG.

Pressure Sensor Type 6157BA... and Type 6157BC...

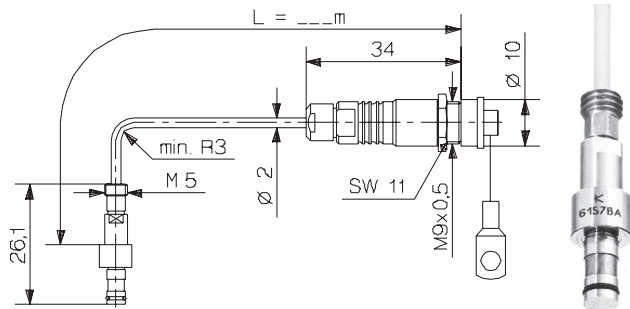

Sensor including an exchangeable high temperature cable with a connector for operating temperatures up to 200 °C.

very small cross-section. The single-wire cable is exchangeable and can be cut to length as required by the user. With the single-wire technique the electrical shielding is provided by the mold. Both the cable and the connector therefore have to be completely integrated into the mold. For easy installation a connector is supplied which is self locking and splash proof.

Special Versions

Coated front (abrasion protection)

- Type 6157BA... with coated front: Type 6157BC...
- Type 6157BB... with coated front: Type 6157BD...

Installation

The sensor is normally fixed in the mounting bore with the mounting nut (Type 6457), but a spacer sleeve (Type 6459) can also be used.

Pressure Sensor Type 6157BB... and Type 6157BD...

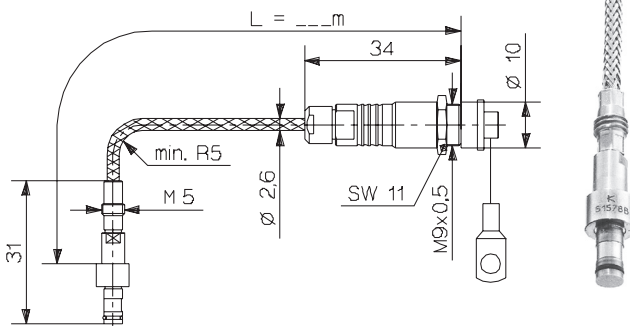

Sensor including an exchangeable steel-braided thermosetting plastic cable (Polyimide) with connector for operating temperatures up to 300 °C (Connector 200 °C).

The sensor front forms part of the cavity wall. The sensor should therefore be adapted so that its front comes exactly flush with the cavity wall. Its front can be machined up to 0,5 mm (except with a coated front!). Full details can be found in the operating instructions.

The sensor is center aligned in the 4 H7 bore.

The single-wire cable must be installed completely in the mold. This connector is fitted in the mounting plate and this secured in a recess in the mold. The identification plate should be fixed nearby, indicating the type of sensor and its sensitivity.

Pressure Sensor Type 6157BAE and Type 6157BCE with Cut-and-Grip-Connector

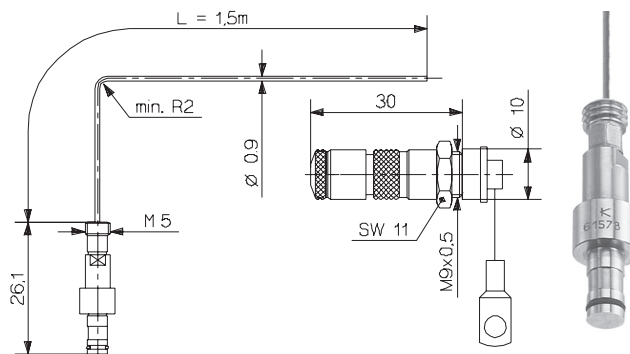

Alternative version of the sensor with single-wire technique for simplified and flexible installation in the mold. The sensor Type 6157B...E is equipped with a single-wire cable with a

6157B_000-030e-09.12

Cable and Amplifier for Measuring Chain with Sensor Type 6157B...

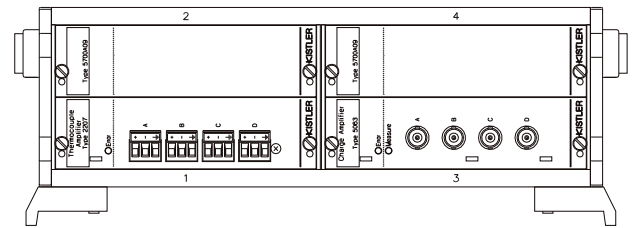
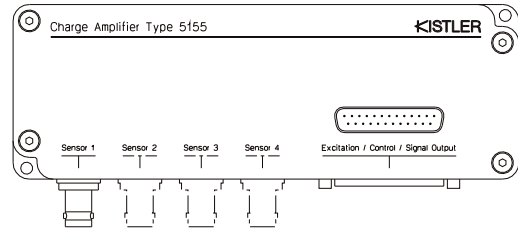
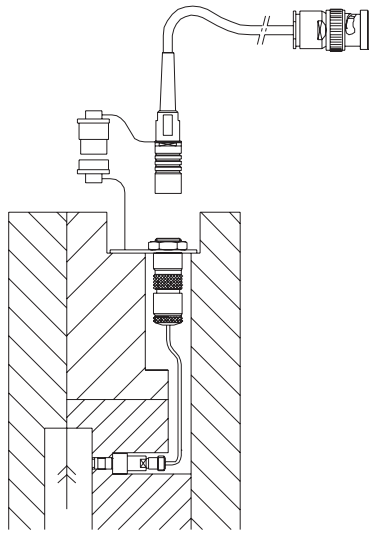

Cable Type 1667B... (BNC Connector)	Cable Type 1672B... (TNC Connector)
Type 5039Axx2	Type 5039Axx1
Type 5049Axx2	Type 5049Axx1
Type 5155Axx2x/Axx4x/Axx8x	Type 5155Axx1x/Axx3x/Axx7x
Type 5063A1 in Type 2859A.../2865...	

Fig. 1: Sensor Type 6157B... with Charge Amplifier Typ 5155A... or Signal Conditioner Type 2859/2865

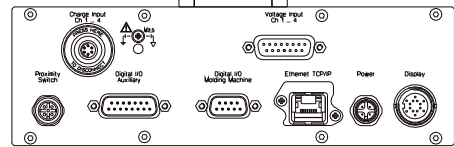
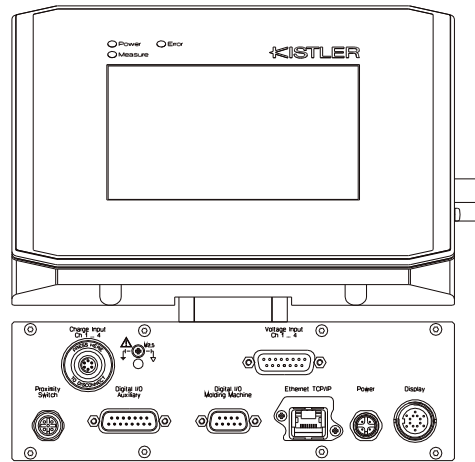
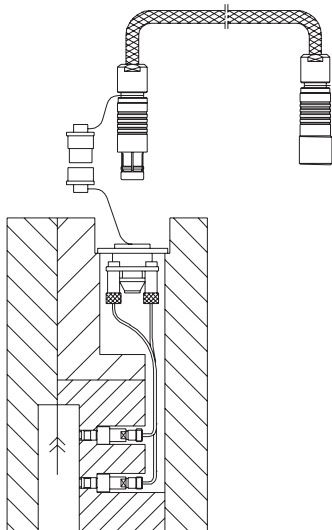

4-Channel Cable Type 1995A... to Connector Type 1708A..	8-Channel Cable Type 1997A... on Connector Type 1710A...
Type 2869A0xx	Type 2869A2xx/2869B2xx
Type 2869A1xx/2869B1xx	Type 2869B3xx

Fig. 2: Sensor Type 6157B... with Monitoring System CoMo Injection Typ 2869...

6157B_000-030e-09_12

Installation Examples

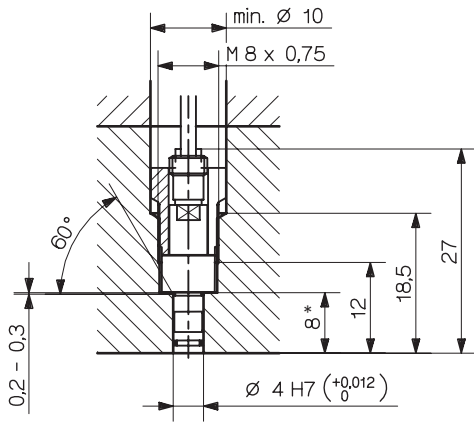

Fig. 3: Installation with mounting nut Type 6457
* Adjust length

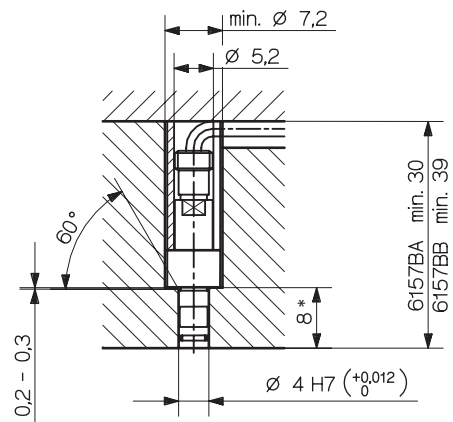

Fig. 4: Installation with spacer sleeve Type 6459
* Adjust length

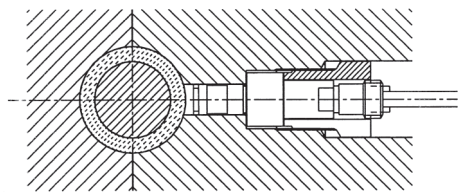

Fig. 5: Sensor with machined front (max. 0,5 mm)

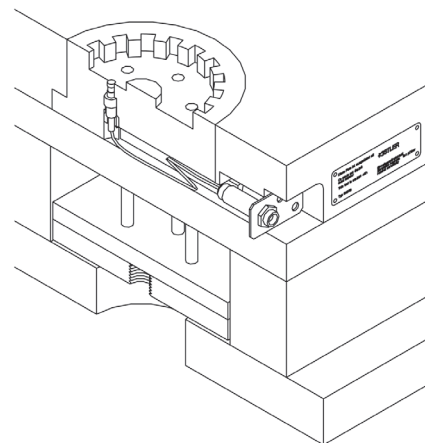

Fig. 6: Sensor, cable, mounting plate (Mat. No. 3.520.328) and identification label (Mat. No. 3.520.899)

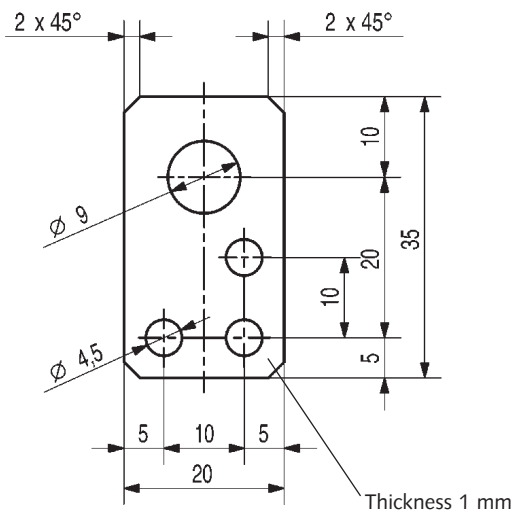

Fig. 7: Mounting plate (Mat. No. 65005208)

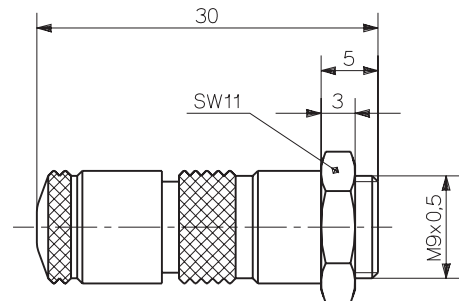

Fig. 8: Single-wire-Fischer-connector Type 1839

6157B_000-030e-09_12

Accessories Included

• Mounting nut	6457
• Mounting plate (for sensor with cable only)	65005208
• Identification label	3.520.899
• Connector (for single-wire technique only) Type 6157BCE and Type 6157BAE)	1839
• O-ring, diameter 2,5x0,65 mm, (only for Type 6157BA...)	1100A57
• O-ring, diameter 2,5x0,65 mm, (only for Type 6157BB...)	1100A67

Optional Accessories

• O-ring tool for exchanging the cable	1364
• High temperature extension cable, Fluoropolymer, Fischer SE102A014 – BNC pos., Length 2 m	1667B2
Length 5 m	1667B5
• High temperature extension cable, sheathed in steel braiding, Fischer SE102A014 – TNC pos., Fluoropolymer, Length 2 m	1672B2
Length 5 m	1672B5
• Dummy sensor	6545
• Spacer sleeve (L = 70 mm)	6459
• 4-channel connector for Type 6157B...G and G1	1708A...
• 8-channel connector for Type 6157B...G and G1	1710A...
• Contact elements 1-channel for single-wire sensor only	1712A0
• Contact elements 4-channel for single-wire sensor only	1714A0
• Two-wire coaxial cable Fluoropolymer (Unisens green) 0 ... 200 °C as replacement cable for sensors Type 6157BA... and Type 6157BC...	1645C...

• Steel-braided two-wire-fluoropolymer cable 0 ... 200 °C as a wear resistant substitute for Type 1645C...	1963A...
• Steel-braided thermosetting plastic cable 0 ... 300 °C as replacement cable for sensors Type 6157BB... and Type 6157BD...	1955A...
• Single wire cable (Unisens green) with M4 connector, 1,5 m length	1666A2
• Single wire cable (Unisens green) with M4 connector, 5 m length	1666A4
• Crimped pin	65003747
• Crimpset with tools	1381A0

Checking Tools

• Limit plug gage, diameter 4 mm, tolerance H75.210.162	
• Checking tool	7.110.300

Mounting Accessories

	Type
• Extraction tool	1315A
• Mounting piece for connector	1401
• Mounting wrench	1383
• Extraction tool for Type 6157BB/BD...	1362A

Ordering Key

Sensor

Up to 200 °C	A
Up to 300 °C	B
Up to 200 °C, sensor front coated	C
Up to 300 °C, sensor front coated	D

Cable

Coaxial cable, L in m (Type 6157BB... and Type 6157BD... only available as 0,4 m and sp)	0,2
	0,4
	0,6
	0,8
	1,2
Coaxial cable with special lengths, specify L in m (L _{min} = 0,1 m/L _{max} = 5 m)	sp
With single-wire-cable available only for Type 6157BA... and Type 6157BC... (L = 1,5 m)	E
With single-wire-cable available only for Type 6157BA... and Type 6157BC... (L = 5 m)	E1
Type 6157BAE or 6157BCE (L = 1,5 m) without connector	G
Type 6157BAE1 or 6157BCE1 (L = 5 m) without connector	G1
For Contact Elements Types 1712A... and 1714A... (only for Types 6157BA... and 6157BC...)	
Sensor with single-wire-cable and crimped pin (Mat. No. 65003747).	Zsp
Cable with special lengths. Indicate L in m. L _{min} = 0,04 m/L _{max} = 1,5 m)	

